

200S READOUTS

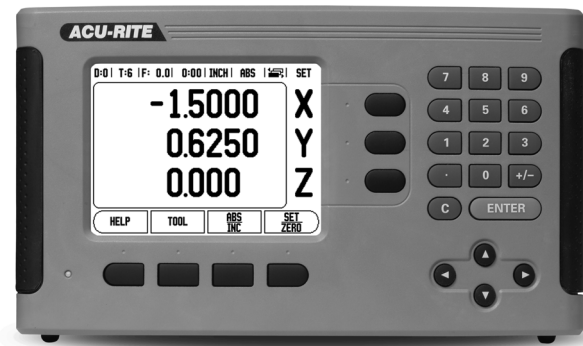

ACU-RITE®

REFERENCE MANUAL

200S Key Layout

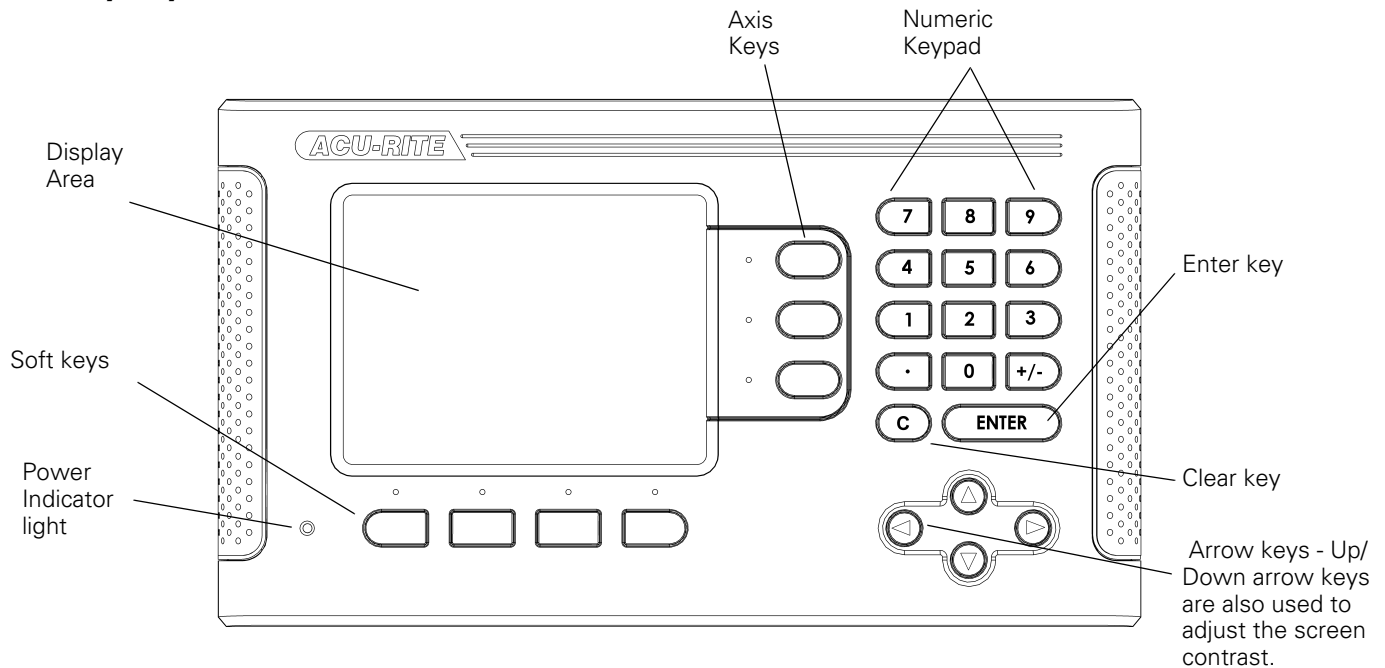

200S Soft Keys

There are three pages of soft key functions to select from the operating modes. Use the Left/Right arrow keys to cursor through each page. The page indicator in the Status Bar will show the page orientation. The darkened page indicates the page you are currently on.

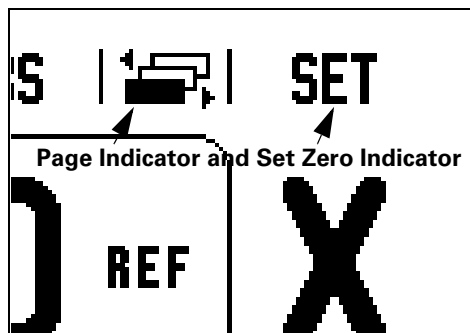

Soft Key function	Soft key Symbol
Opens on-screen help instructions.	HELP
Opens the Tool Table. (Page 7 for Milling. Page 16 for Turning)	TOOL
Switches display between operating modes Actual Value(Absolute)/Distance-To-Go(Incremental). (Page 2)	ABS INC
Toggles between Set/Zero functions. Used with individual axis keys. (Page 6)	SET ZERO

Soft Key function	Soft key Symbol
Opens the Datum form to set the datum for each axis. (Page 8)	DATUM
Opens the Preset form. This form is used to set a nominal position. This is a Distance-To-Go (Incremental) function (Page 10)	PRESET
Used to divide the current position by two. (Page 13)	1/2
Opens the Circle and Linear Pattern forms. This is a Distance-To-Go (Incremental) function for Milling applications only. (Page 13)	PATTERN
This soft key toggles between radius and diameter displays. This function is for Turning applications only. (Page 19)	RAD DIA

Soft Key function	Soft key Symbol
Opens the Job Setup menu and provides access to the Installation Setup soft key. (Page 21)	SETUP
Press when ready to identify a reference mark. (Page 3)	ENABLE REF
Opens the Calculator functions for standard math, trigonometry, RPM and Taper for Turning functions.	CALC
Toggles between inch and millimeter units. (Page 3 under Units)	INCH MM

Readout Parameter Access Code

An access code must be entered before machine-related installation parameters can be set or changed. This prevents inadvertent adjustments to the installation setup parameters.

IMPORTANT
The access code is 8891

Refer to the Setup section. Begin by pressing the **SETUP** key. Then the Installation Setup soft key, then press the **8 8 9 1** and **ENTER** keys. The readout is now ready for machine parameter setting operations.

IMPORTANT
Supervisors may wish to remove this page from the Reference Manual after initially setting up the readout system. Retain in a safe place for future use.

Warranty

ACU-RITE Companies, Inc. products and accessories are warranted against defects in material and workmanship for a period of three (3) years from the date of purchase. ACU-RITE will, at its option and expense, repair or replace any part of the ACU-RITE product that fails to meet this warranty. This warranty covers both materials and factory labor. In addition, authorized ACU-RITE service representatives will provide service labor (field service) for a period of one (1) year at no charge. Notice of the claimed defect must be received by ACU-RITE within the warranty period.

This warranty applies only to products and accessories installed and operated in accordance with this reference manual. ACU-RITE shall have no obligation, with respect to any defect or other condition caused in whole or part by the customer's incorrect use, improper maintenance modification of the equipment, or by the repair or maintenance of the product by any person except those deemed qualified by ACU-RITE.

Responsibility for loss of operation or diminished performance due to conditions beyond ACU-RITE's control cannot be accepted by ACU-RITE.

The foregoing warranty obligations are in lieu of all expressed or implied warranties. ACU-RITE Companies, Inc. shall not be liable under any circumstances for consequential damages.

Hassle-Free Warranty

ACU-RITE Companies, Inc. is proud to offer the 3-Year Hassle-Free Warranty for all digital readout systems, vision readout systems and precision glass scales. This warranty will cover all of the ACU-RITE repair and replacement costs for any readout or precision glass scale returned during the three (3) year warranty period. ACU-RITE will repair or replace the damaged components - regardless of the product's condition absolutely free, no questions asked.

Table of Contents

I-1	Introduction to 200S	1
	Layout of Screen	1
	Operating Modes	2
	Reference Mark Evaluation	2
	ENABLE/DISABLE REF function	3
	Job Setup Parameters	3
	Units	3
	Scale Factor	3
	Mirror	3
	Edge Finder (milling applications only)	3
	Diameter Axes	4
	Measured Value Output	4
	Near Zero Warning	4
	Status Bar Settings	4
	Job Clock	4
	Remote Switch	5
	Console Adjustment	5
	Language	5
	Import/Export	5
	Set/Zero Soft Key Details	6
I-2	Milling Specific Operations	7
	Soft Key Functions Detailed	7
	Tool Soft Key	7
	Tool Table	7
	Tool Compensation	7
	Calling the Tool from the Tool Table	8
	Datum Soft Key	8
	Preset Soft Key	10
	Absolute Distance Preset	10
	Incremental Distance Preset	12
	1/2 Soft Key	13
	Patterns Soft Key (Milling)	13
	Functions for milling patterns	13
	Linear Pattern	15
I-3	Turning Specific Operations	16
	Soft Keys Functions Detailed	16
	Tool Soft Key Function Display Icon	16
	Tool Soft Key	16
	Datum Soft Key	18
	Preset Soft Key (Turning)	19
	Radius/Diameter Soft Key	19
	Vectoring	19

II-1	Installation Setup	21
	Installation Setup Parameters	21
	Encoder Setup	21
	Display Configuration	22
	Coupling	22
	Z Coupling	22
	Enabling Z Coupling	23
	Disabling Z Coupling	23
	Error Compensation	23
	Linear Error Compensation	24
	Non-Linear Error Compensation	24
	Backlash Compensation	26
	Serial Port	26
	Counter Settings	27
	Diagnostics	27
	Display Test	27
	Edge Finder Test	27
	Keypad Test	27
II-2	RS-232C Serial Communications	28
	Serial port	28
II-3	Installation and Electrical Connections	29
	Installation	29
	Electrical requirements	29
	Environmental	29
	Preventative maintenance	29
II-4	I/O Connections	30
	Wiring the serial communication cable	31
	Pin assignment	31
	Signal	31
II-5	Remote Switch Data Output	32
	Data output using external signals	32
	Data output using Edge Finder	33
II-6	Dimensions	34

I – 1 Introduction to 200S

Layout of Screen

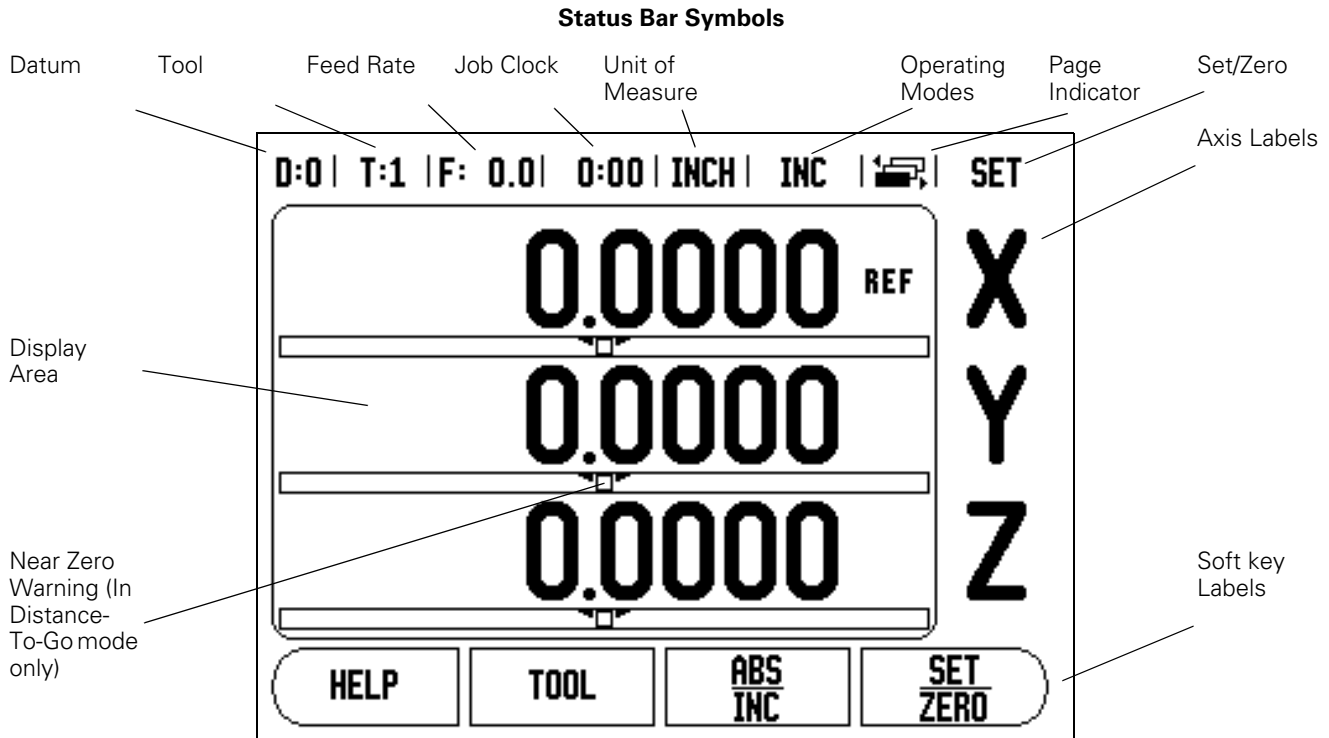

ACU-RITE's 200S readout provides application-specific features that allows you to obtain the most productivity from your manual machine tools.

- **Status Bar** - This displays the current datum, tool, feed rate, job clock time, unit of measure, operating mode status, page indicator, and set/zero. See Job Setup for details on setting up the Status Bar parameters.
- **Display Area** - Indicates the current position of each axis. Also shows forms, fields, instruction boxes, error messages and help topics.
- **Axis Labels** - Indicates axis for corresponding axis key.
- **Ref Symbols** - Indicates current reference mark status.
- **Soft key Labels** - Indicates the various milling or turning functions.

Operating Modes

The 200S has two operating modes **Actual Value (Absolute)** and **Distance-To-Go (Incremental)**. The Actual Value mode always displays the current actual position of the tool, relative to the active datum. In this mode, all moves are done by traveling until the display matches the nominal position that is required. The Distance-To-Go feature enables you to approach nominal positions simply by traversing to display value zero. When working within the Distance-To-Go mode you can enter nominal coordinates as either absolute or incremental dimensions.

While in the Actual Value Mode, if the 200S is configured for Milling applications, only the tool length offsets are active. Both the diameter and length offsets are used in the Distance-To-Go mode to calculate the amount of “distance-to-go” required to get to the desired nominal position relative to the edge of the tool that will be doing the cutting.

If the 200S is configured for turning, all tool offsets are used in both the Actual Value and Distance-To-Go modes.

Press the **ABS/INC** soft key to toggle between these two modes. To view other soft key functions in either Actual Value or Distance-To-Go mode, use the Left/Right arrow keys.

The turning application provides a quick method for coupling the Z axes position on a 3 axis system. For more information, see “Coupling” on page 22.

Reference Mark Evaluation

The 200S reference mark evaluation feature automatically re-establishes the relationship between axis slide positions and display values that you last defined by setting the datum.

For each axis with an encoder that has reference marks the REF indicator will flash for that axis (See Fig. I.2). After crossing over the reference marks, the indicator will stop flashing and change to a non-flashing “REF”.

Working without reference mark evaluation

You can also use the 200S without crossing over the reference marks. Press the **NO REF** soft key to exit the reference mark evaluation routine and continue.

You can still cross over reference marks at a later time if it becomes necessary to define datums that can be re-established after a power interruption. Press the **ENABLE REF** soft key to activate the position recovery routine.



If an encoder is setup without reference marks, then the REF indicator will not be displayed, and datums set from any axis will be lost once power is turned off.



Fig. I.1 Actual Value/Distance-To-Go soft key

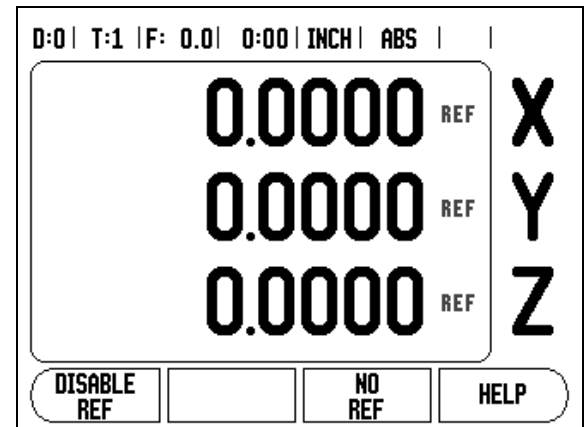

Fig. I.2 Screen for establishing Ref Marks

ENABLE/DISABLE REF function

The Enable/Disable toggle soft key, that is present during the position recovery routine, allows the operator to select a specific reference mark on an encoder. This is important when using encoders with Fixed Reference Marks (instead of ones with Position-Trac™ feature). When the **DISABLE REF** soft key is pressed, the recovery routine is paused and any reference marks that are crossed during encoder movement are ignored. When the **ENABLE REF** soft key is then pressed, the recovery routine once again becomes active and the next crossed reference mark will be selected.

You do not have to cross over the reference marks of all the encoders, only those that you need. Once reference marks for all desired axes are established, press **NO REF** soft key to cancel out of routine. If all reference marks have been found the 200S will return to the DRO display screen automatically.

Job Setup Parameters

To view and change Job Setup parameters, first press the **SETUP** soft key, then use the Up/Down arrow keys to highlight the parameters of interest and press the Enter key.

Units

The Units form is used to specify the preferred display units and format. You can also select the unit of measure by pressing the **INCH/MM** soft key in either Actual Value or Distance-To-Go mode.

Scale Factor

The scale factor may be used to scale the part up or down. A scale factor of 1.0 creates a part with the exact size as dimensioned on the print. A scale factor >1 "grows" the part, and <1 "shrinks" the part.

- ▶ The numeric keys are used to enter a number greater than zero. The number range is 0.1000 to 10.000. A negative value may also be entered.
- ▶ The scale factor settings will be retained on a power cycle.
- ▶ When the scale factor is a value other than 1, the scaling symbol ∇ is shown on the axis display.
- ▶ The On/Off soft key is used to disable the current scale factors.

Mirror



A scale factor of -1.00 will produce a mirror image of the part. You can both mirror and scale a part at the same time.

Edge Finder (milling applications only)

The diameter, length offset and units of the edge finder are set in this form. Both values are in the units indicated in the form. Please see "Probing Functions for Datum Setting" on page 9 for details on using Edge Finder functions.

- ▶ The numeric keys are used to enter values of diameter and length. The diameter must be greater than zero. The length is a sign value (negative or positive).

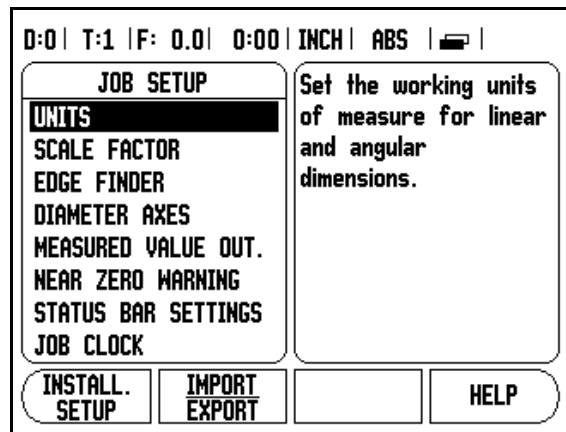

Fig. I.3 Job Setup screen in milling

- ▶ A soft key is provided to indicate the units of measure for the edge finder.

The edge finder values will be retained on a power cycle.

Diameter Axes

Select Diameter Axes to set which axes can be displayed in either radius or diameter values. ON indicates that the axis position will be displayed as a diameter value. When OFF, the Radius/Diameter feature does not apply. See Fig. I.4. For turning applications see "Radius/Diameter Soft Key" on page 19 for the Radius/Diameter feature.

- ▶ Cursor to Diameter Axes and press **ENTER**.
- ▶ The cursor will be in the X axis field. Depending on the parameter you need for that axis press **ON/OFF** soft key to turn feature on or off.
- ▶ Press **ENTER**.

Measured Value Output

With the measured value output feature, probe measurement values can be sent over the serial port. Also output of the current display positions is activated via a command (Ctrl B) sent to 200S over the serial port.

The Measured Value Output form is used to set data output during probing operations to On or Off.

- ▶ Data Output Probing (Milling Only) - This may be set to either On or Off. When On, the measurement data is output when the probe operation is completed.

Refer to chapter "II – 5 Remote Switch Data Output on page 32" for information on the format of the output data.

Near Zero Warning

The Near Zero Warning form is used to configure the bar graph that is shown below the axes' display in Distance-To-Go mode. Each axis has its own range.

- ▶ Press the **ON/OFF** soft key to enable or simply begin entering values using the numeric keys. The current position box will begin moving when the position is within range.

Status Bar Settings

The Status Bar is the segmented bar at the top of the screen which displays current datum, tool, feed rate, job clock and page indicator.

- ▶ Press the **ON/OFF** soft key for each setting you want to see displayed.

Job Clock

The job clock shows the hours (h), minutes (m), seconds (s). It operates like a stop watch showing elapsed time. (The clock starts timing from 0:00:00).

The elapsed time field shows the total accumulated time from each interval.

- ▶ Press the **START/STOP** soft key. The status field will read RUNNING. Press it again to stop time from elapsing.

DIAMETER AXES	
X	OFF
Y	OFF
Z	OFF

Set to ON to display the position as a diameter value.

ON/OFF HELP

Fig. I.4 Diameter Axes form

- ▶ Press **RESET** to reset the elapsed time. Resetting will stop the clock if it is running.



Pressing the Decimal key while in operating mode, will also stop and start the clock. Pressing the Zero key will reset the clock.

Remote Switch

The **remote switch** sets the parameters so the external switch (pendant or foot switch) can be enabled to perform any or all of the following functions: Data Output, Zero and Next Hole. Refer to Section II for information on connecting remote switches via Grounding Edge Finder input (See Grounding Edge Finder Fig. II.6).

- Data Output - to send position information out of the serial port or to print the current position.
- Zero - to zero one or more axes. (If you are in Distance-To-Go mode it will zero the Distance-To-Go display. If in Actual Value mode it will zero the datum).
- Next Hole - to move to the next hole within a pattern (i.e. Hole Pattern).
 - While in the DATA OUTPUT field, press the **ON/OFF** soft key to ON to send the current position over the serial port when the switch is closed.
 - While in the ZERO field, press the appropriate axis keys to enable or disable zeroing of the axis display positions when the switch is closed.
 - While in the (NEXT HOLE) field, press the **ON/OFF** soft key to ON to move to the next hole within a pattern.

Console Adjustment

The LCD's brightness and contrast can be adjusted either by using the soft keys in this form or by using the Up/Down arrow keys on the keypad in either operating mode. The settings of brightness and contrast may need to be adjusted due to variations in ambient lighting and operator preference. This form is also used to set the display saver's idle time-out. The display saver setting is the amount of time the system is idle before the LCD is turned off. The idle time may be set from 30 to 120 minutes. The display saver can be disabled during the current power cycle.

Language

The 200S supports multiple languages. To change the language selection:

- ▶ Press the **LANGUAGE** soft key until the desired language selection appears on the soft key and the form.
- ▶ Press **ENTER** to confirm your selection.

Import/Export

Job and Installation Setup parameters can be imported or exported over the serial port.

- ▶ Press the **IMPORT/EXPORT** soft key in the Setup screen.
- ▶ Press **IMPORT** to download operating parameters from a PC.
- ▶ Press **EXPORT** to upload the current operating parameters to a PC.
- ▶ To exit, press the **C** key.

Set/Zero Soft Key Details

The **SET/ZERO** soft key is a key that determines the effect of pressing an Axis key. This key is a toggle key, switching the functionality between Set and Zero. The current state is indicated in the Status Bar.

When the state is Set, and the 200S is in Actual Value mode, selecting an Axis key opens the Datum form for the selected axis. If the 200S is in Distance-To-Go mode, a Preset form opens.

When the state is Zero, and the 200S is in Actual Value mode, selecting an Axis key sets the current datum for that axis to zero at the current position. If it is in Distance-To-Go mode, the current Distance-To-Go value is set to zero.



If the 200S is in Actual Value mode and the state of Set/Zero is zero, pressing any Axis key resets the current datum to zero at the current location for that axis.

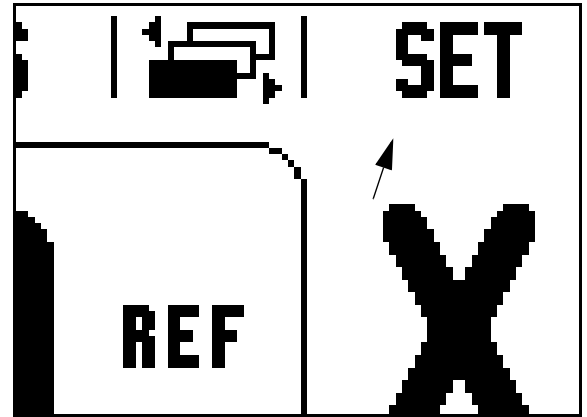

Fig. I.5 Set Zero Indicator

I – 2 Milling Specific Operations

This section discusses operations and soft key functions specific to milling applications only.

Soft Key Functions Detailed

Tool Soft Key

This soft key opens the tool table and provides access to the Tool form for entering a tool's parameters. The 200S can store up to 16 tools within the tool table.

Tool Table

The 200S tool table provides a convenient way to store diameter and length offset information for each of the tools you commonly use. You can enter up to 16 tools. See Fig. I.6.

The following soft keys are also available while in the Tool Table form or in the individual tool data form:

Function	Soft key
This key allows the operator to select which axis all the tool length offsets will effect. The tool's diameter values will subsequently be used to offset the remaining two axes.	TOOL AXIS [Z]
Press to automatically enter the tool offset length. Only available in TOOL LENGTH field.	TEACH LENGTH
This will open the TOOL TYPES form for selection. Only available in TYPE field.	TOOL TYPES

D:0 T:1 F: 0.0 0:00 INCH ABS 			
TOOL TABLE (DIA/LENGTH)			
1	2.000/	20.000 MM	ENGRAVE
2	5.000/	14.000 MM	PILOT DR
3	25.000/	50.000 MM	CTR-BORE
4	6.000/	12.000 MM	CARB ML
5	10.000/	25.000 MM	BROACH
6	2.000/	0.000 MM	FL END ML
7	2.500/	0.000 MM	FL END ML
8	3.000/	5.000 MM	
TOOL AXIS [Z]	CLEAR TOOL		HELP

Fig. I.6 Tool Table in Milling

Tool Compensation

200S has tool compensation. This allows you to enter workpiece dimensions directly from the drawing. The displayed distance to go is then automatically lengthened (R+) or shortened (R-) by the value of the tool radius. See Fig. I.7. (For more information see "Preset Soft Key" on page 10).

The length offset may be entered as a known value or the 200S may determine the offset automatically. See the following Tool Table Usage example for more information regarding the Teach Length soft key.

The tool length is the difference in length ΔL between the tool and the reference tool. The length difference is indicated with the " Δ " symbol. The reference tool is indicated by T1 in Fig. I.8.

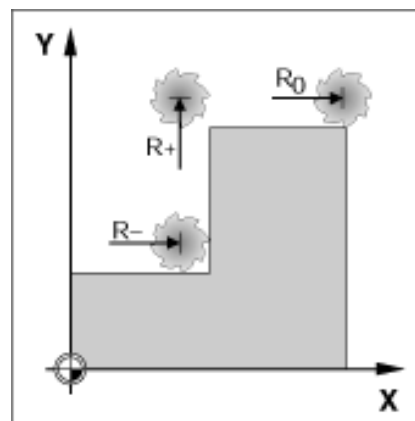



Fig. I.7 Tool compensation

Sign for the length difference ΔL

If the tool is **longer** than the reference tool: $\Delta L > 0 (+)$
 If the tool is **shorter** than the reference tool: $\Delta L < 0 (-)$

As indicated above it is also possible to have the 200S determine a tool's length offset. This method involves touching the tip of each tool to a common reference surface. This allows the 200S to determine the difference between the length of each tool.

Move the tool until its tip is touching the reference surface. Press the **TEACH LENGTH** soft key. The 200S will calculate an offset relative to this surface. Repeat the procedure for each additional tool using the same reference surface.

 Only the tools set using the same reference surface may be changed without having to reset the datum.

Calling the Tool from the Tool Table

To call a tool, press the **TOOL** soft key. Use the UP/DOWN arrow keys to cursor through the selection of tools (1-16). Highlight the tool you want. Verify the proper tool has been called, and press the C key to exit.

Datum Soft Key

Datum settings define the relationships between the axis positions and the display values.

The easiest way to set datum points is to use the 200S probing functions – regardless of whether you probe the workpiece with an edge finder or a tool.

Of course, you can also set datum points in the conventional manner by touching the edges of the workpiece, one after the other with a tool and manually entering the tool positions as datum points (see examples following this page). Fig. I.9 & Fig. I.10

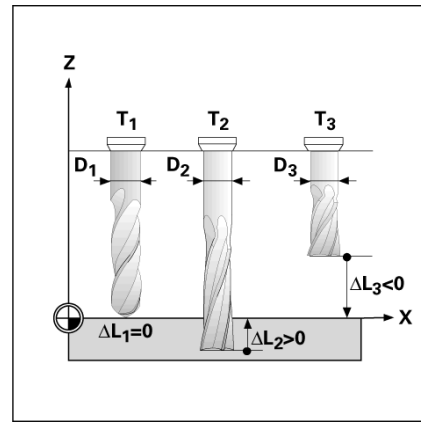

Fig. I.8 Tool length and diameter

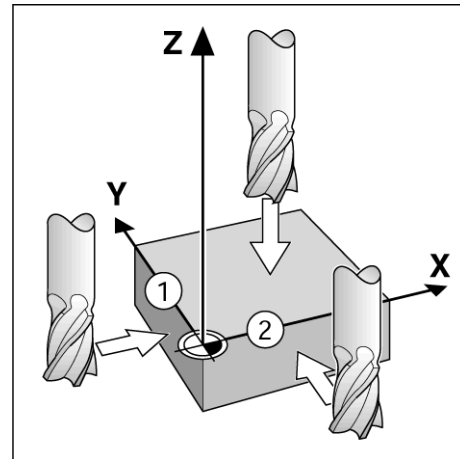

Fig. I.9 Touching the edges

D:1 T:1 F: 0.0 0:00 INCH ABS		SET
SET DATUM		X 0.0000 Y 0.0000 Z 0.0000
DATUM NUMBER 1		
DATUM		Enter the new actual position of the tool or press PROBE.
X	-1.5000	
Y	-1.5000	
Z	0	X Y Z
PROBE		

Fig. I.10 SET DATUM form

Probing Functions for Datum Setting

It is particularly easy with an electronic Edge Finder connected through the edge finder input. The 200S also supports a grounding type edge finder connected via the 3.5mm Phono Jack on the back of the unit. Both types of edge finders operate the same way.

The following probing soft key functions are available:

- Workpiece edge as datum: **EDGE**
- Centerline between two workpiece edges: **CENTER LINE**
- Center of a hole or cylinder: **CIRCLE CENTER**

In all probing functions, 200S takes into account the probes's entered tip diameter. During probing functions, with an electronic or grounding edge finder, the display freezes with the location of the edge, centerline, or circle center.

To abort the probing function while it is active, press the C key.



To perform probing, the probe's dimensional characteristics must first be entered into Job Setup (see "Job Setup Parameters" on page 3).

Probing with a Tool

Even if you use a tool or non-electrical edge finder to set datum points, you can still use 200S probing functions. See Fig. I.11 & Fig 1.12.

Example: Probe workpiece edge and set edge as datum

Preparation: Set the active tool to the tool that will be used to set the datum

Datum axis: X = 0

Tool diameter D = 0.25"

Press **DATUM**.

Press the Down arrow key until the X axis field is highlighted.

Press **PROBE** soft key.

Press **EDGE** soft key.

Touch workpiece edge.

Store the position of the edge by pressing the **TEACH** soft key.

The **TEACH** soft key is useful when determining tool data by touching the workpiece in the absence of an edge finder with feedback. Press the **TEACH** soft key to store the current absolute value while the tool is in contact with the workpiece edge. The location for the touched edge will take into account the diameter of the tool in use (T:1, 2...) and **the last direction the tool was moved** prior to pressing the **TEACH** soft key.

Retract the tool from the workpiece and enter 0" and then press **ENTER**.

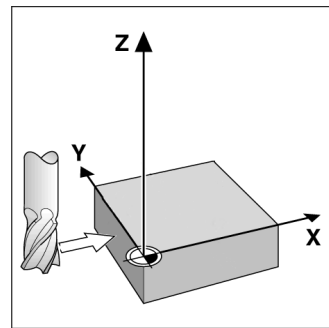

Fig. I.11 Setting datum using an edge

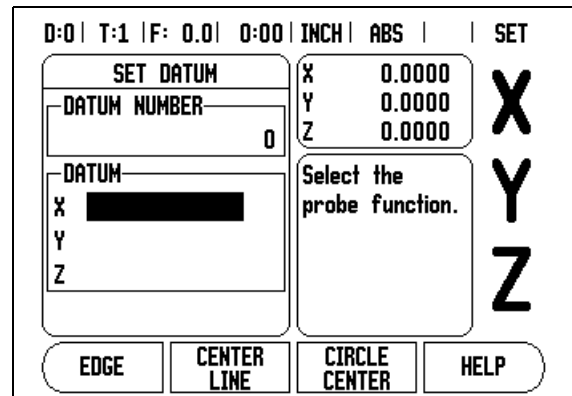

Fig. I.12 Set Datum screen

Preset Soft Key

The Preset function allows the operator to indicate the nominal (target) position for the next move. Once the new nominal position information is entered the display will switch to Distance-To-Go mode and show the distance between the current position and the nominal position. The operator now only needs to move the table until the display is zero and he will be at the required nominal position. The information for the location of the nominal position can be entered as an absolute move from the current datum zero or as an incremental (I) move from the current nominal position.

Presetting also allows the operator to indicate which side of the tool will be doing the machining at the nominal position. The **R+/-** soft key in the Preset form defines the offset that will be in effect during the move. R+ indicates that the center line of the current tool is in a more positive direction than the edge of the tool. R- indicates that the center line is in a more negative direction than the edge of the current tool. Using R+/- offsets automatically adjusts the distance-to-go value to account for the diameter of the tool. See Fig. I.13

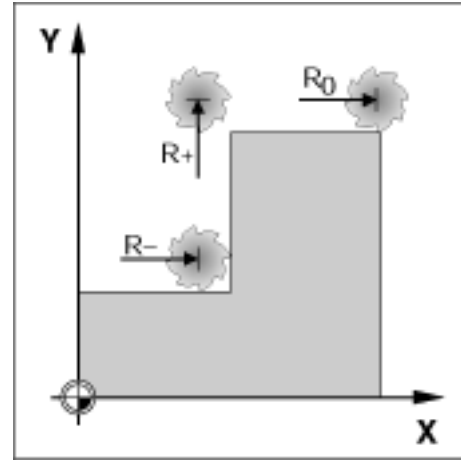

Fig. I.13 Tool radius compensation

Absolute Distance Preset

Example: Milling a shoulder by traversing to display value zero using absolute position

The coordinates are entered as absolute dimensions; the datum is the workpiece zero. See Fig. I.14 & Fig. I.15.

Corner 1: X = 0 / Y = 1

Corner 2: X = 1.50 / Y = 1

Corner 3: X = 1.50 / Y = 2.50

Corner 4: X = 3.00 / Y = 2.50



If you would like to recall the last entered preset for a particular axis, press the **PRESET** soft key and then the Axis key.

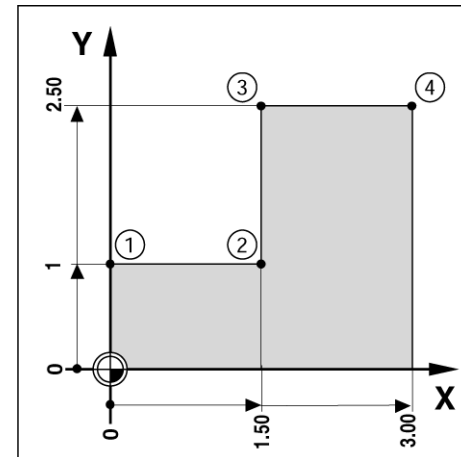

Fig. I.14 Single cycle preset

Preparation:

- ▶ Select the tool with the appropriate tool data.
- ▶ Pre-position the tool to an appropriate location (such as X = Y = -1").
- ▶ Move the tool to milling depth.

Press the **PRESET** soft key.

Press the Y axis key.

- ALTERNATIVE METHOD -

Press the **SET/ZERO** soft key so that you are in Set mode.

Press the Y axis key.

Enter nominal position value for corner point 1: Y = 1" and select tool radius compensation R + with **R+/-** soft key. Press until R+ is shown next to axis form.

Press **ENTER**.

Traverse the Y axis until the display value is zero. The square in the near zero warning is now centered between the two triangular marks.

Press the **PRESET** soft key.

Press the X axis key.

- ALTERNATIVE METHOD -

Press the **SET/ZERO** soft key so that you are in Set mode.

Press the X axis key.

Enter nominal position value for corner point 2: X = +1.5", select tool radius compensation R – with **R+/-** soft key. Press twice until R- is shown next to axis form.

Press **ENTER**.

Traverse the X axis until the display value is zero. The square in the near zero warning is now centered between the two triangular marks.

Presets can be entered in the same manner for corners 3 and 4.

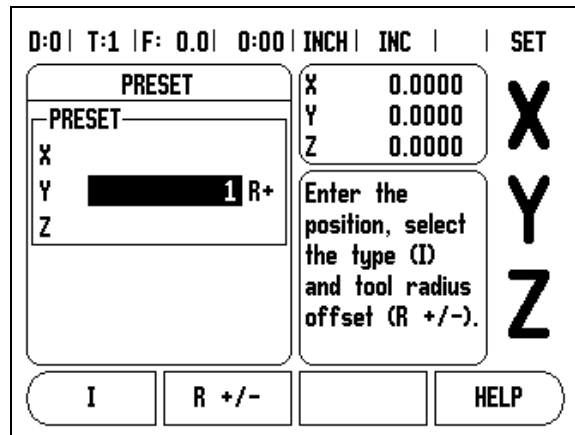

Fig. I.15 Preset screen

Incremental Distance Preset

Example: Drilling by traversing to display value zero with incremental positioning

Enter the coordinates in incremental dimensions. These are indicated in the following (and on the screen) with a preceding **I** (Incremental). The datum is the workpiece zero. See Fig. I.16 & Fig. I.17.

Hole 1 at: $X = 1'' / Y = 1''$

Distance from hole 2 to hole 1: $XI = 1.5'' / YI = 1.5''$

Hole depth: $Z = -0.5''$

Operating mode: **DISTANCE-TO-GO (INC)**

Press the **PRESET** soft key.

Press the X axis key.

Enter nominal position value for hole 1: $X = 1''$ and ensure no tool radius is active. Note that these presets are Absolute Presets.

Press the Down arrow key.

Enter nominal position value for hole 1: $Y = 1''$.

Ensure no tool radius compensation is showing.

Press the Down arrow key.

Enter the nominal position value for the hole depth: $Z = -0.5''$. Press **ENTER** soft key.

Drill hole 1: Traverse the X, Y and Z axis until the display value is zero. The square in the near zero warning is now centered between the two triangular marks. Retract the drill.

To preset the location for Hole 2.

Press the **PRESET** soft key.

Press the X axis key.

Enter nominal position value for hole 2: $X = 1.5''$, mark your input as an incremental dimension, press the **I** soft key.

Press the Y axis key.

Enter nominal position value for hole 2: $Y = 1.5''$, mark your input as an incremental dimension, press the **I** soft key.

Press **ENTER**.

Traverse the X and Y axes until the display value is zero. The square in the near zero warning is now centered between the two triangular marks.

To preset the Z axis:

Press the **PRESET** soft key.

Press the Z axis key.

Press the **ENTER** key (use last entered preset).

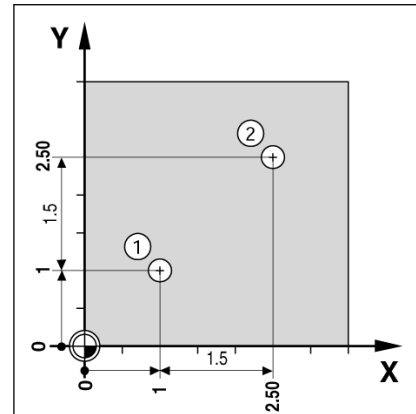

Fig. I.16 Drilling example

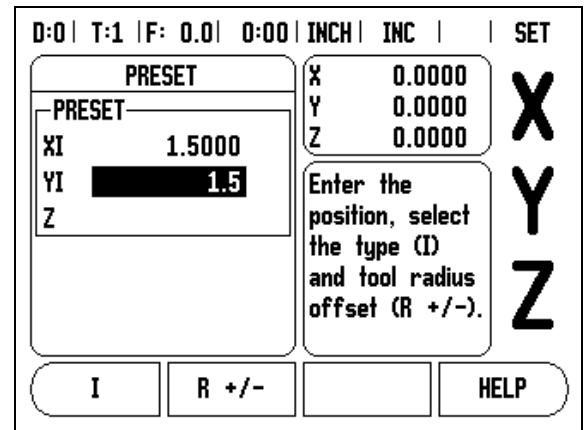

Fig. I.17 Incremental screen

Drill hole 2: Traverse Z axis until the display value is zero. The square in the near zero warning is now centered between the two triangular marks.

Retract the drill.

1/2 Soft Key

The **1/2** soft key is used to find the centerline (or midpoint) between two locations along a selected axis of a workpiece. This can be performed in either Actual Value or Distance-To-Go mode.



This feature will change datum locations when in Actual Value mode.

Patterns Soft Key (Milling)

This section describes the hole pattern functions for Circle and Linear patterns.

Press the **PATTERN** soft key to access the Pattern function. Use the soft keys to select the desired hole pattern function and enter the required data. The 200S then calculates the positions of all the holes and displays the pattern graphically on the screen.

The View Graphic enables verification of the hole pattern before you start machining. It is also useful when: selecting holes directly, executing holes separately, and skipping holes.

Functions for milling patterns

Function	Soft key
Press this to see the layout of the current pattern.	
Press to go to previous hole.	
Press to manually advance to the next hole.	
Press to end drilling.	

Example: Enter data and execute a circle pattern. See Fig. I.18 & Fig. I.19.

Holes (no. of): 4
 Coordinates of center: X = 2.0" / Y = 1.5"
 Bolt circle radius: 5
 Start angle: Angle between X axis and first hole: 25°
 Hole depth: Z = -0.25"

1st step: Enter data

Press **PATTERN** soft key.

Press **CIRCLE PATTERN** soft key.

Enter the type of circle pattern (full). Cursor to the next field.

Enter the number of holes (4).

Enter the X and Y coordinates of the circle center (X=2.0), (Y=1.5).
 Cursor to the next field.

Enter the radius of the circle pattern (5).

Enter the start angle (25°).

Enter the end angle (295°) (this can only be changed if entering a "segment"). The END ANGLE is defined as the angle from the positive X-axis to the end of the pattern.

Enter the depth when needed. The depth of the hole is optional and may be left blank. If not required, press **ENTER**.

Pressing the **VIEW** soft key will toggle between the two views of the pattern (the Graphic and DRO).

2nd step: Drill

Move to hole:

Traverse the X and Y axes until display value zero.

Drill:

Traverse to display value zero in the tool axis. After drilling, retract the drill in tool axis.

Press the **NEXT HOLE** soft key.

Continue to drill the remaining holes in the same way.

When the pattern is complete, press the **END** soft key.

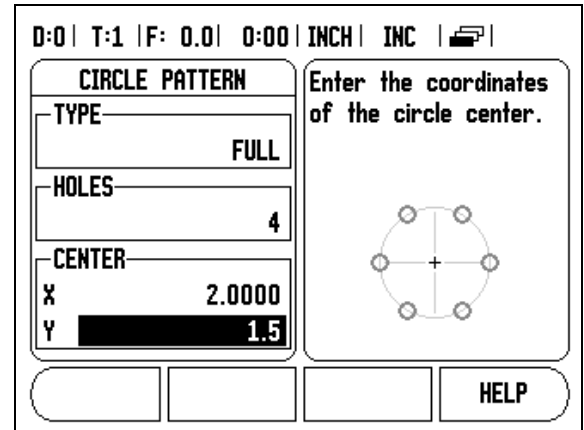

Fig. I.18 Beginning of Circle Pattern form

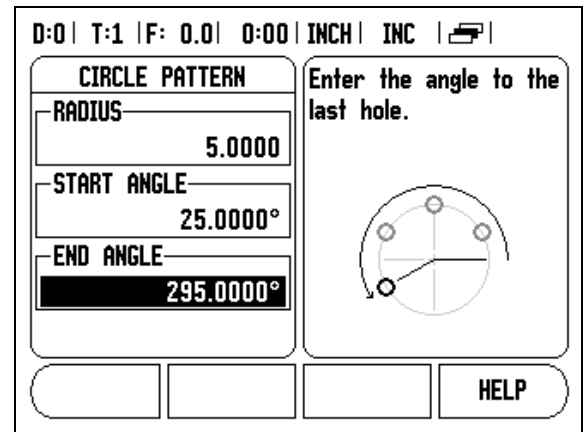

Fig. I.19 Page 2 of Circle Pattern Form

Linear Pattern

Information required (See Fig. I.20):

- Linear pattern type (array or frame)
- First hole (1st hole of the pattern)
- Holes per row (number of holes in each row of pattern)
- Hole spacing (the spacing or offset between each hole in the row)
- Angle (the angle or rotation of the pattern)
- Depth (the target depth for drilling in the tool axis)
- Number of rows (number of rows in the pattern)
- Row spacing (the spacing between each row of the pattern)

Information entry and operation of the Linear Pattern feature is very similar to the Hole Pattern feature described earlier.

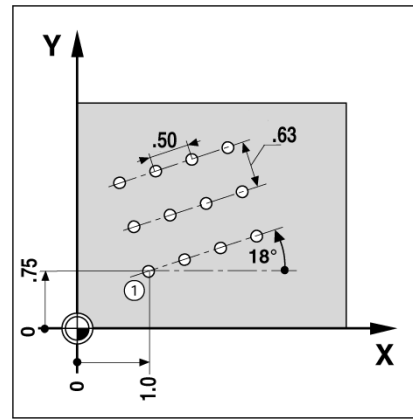

Fig. I.20 Linear Pattern Example

I – 3 Turning Specific Operations

This section discusses operations and soft key functions specific to turning applications only.

Soft Keys Functions Detailed

Tool Soft Key Function Display Icon

The Ø icon is used to indicate that the displayed value is a diameter value. No icon visible indicates that the display is a radius value.

Tool Soft Key

The 200S can store the dimensional offsets for up to 16 tools. When you change a workpiece and establish a new datum, all tools are automatically referenced from the new datum.

Before you can use a tool, you must enter its offset (the cutting edge position). Tool offsets can be set using the TOOL/SET or LOCK AXIS features. See the following examples for instructions on Tool Offsetting (See Fig. I.21).

Setting Tool Offsets Example 1: Using TOOL/SET

The TOOL/SET operation can be used to set a tool's offset using a tool when the diameter of the workpiece is known. Touch the known diameter in the X axis. Press the **TOOL** soft key. Scroll to the desired tool. Press the **ENTER** key. Select the axis (X) key.

Enter the position of the tool tip, for example, X= .100.

Remember to ensure the 200S is in diameter display mode (Ø) if you input a diameter value. Touch the workpiece face with the tool. Cursor to the Z axis. Set the position display for the tool tip to zero, Z=0. Press **ENTER**.

TOOL TABLE (X/Z)		
1	1.5200Ø	0.0000
2	0.0000Ø	0.0000
3	0.0000Ø	0.0000
4	0.0000Ø	0.0000
5	2.4500Ø	0.0000
6	0.0000Ø	0.0000
7	0.0000Ø	0.0000
8	0.0000Ø	0.0000

Fig. I.21 Tool table in turning

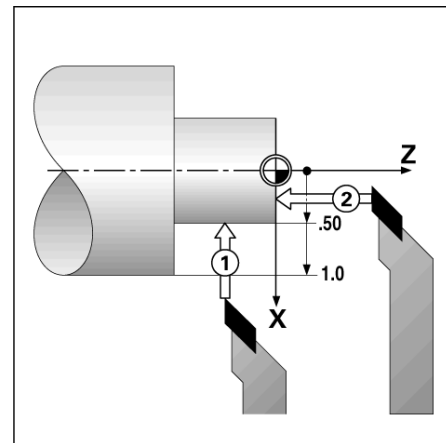

Fig. I.22

Setting Tool Offsets Example 2: Using LOCK AXIS Function

The LOCK AXIS function can be used to set a tool's offset when a tool is under load and the diameter of the workpiece is not known. See Fig. I.23.

The LOCK AXIS function is useful when determining tool data by touching the workpiece. To avoid losing the position value when the tool is retracted to measure the workpiece, this value can be stored by pressing **LOCK AXIS**.

To use the LOCK AXIS function:

Press the **TOOL** soft key. Select tool and press **ENTER**. Select the X axis key. Turn a diameter in the X axis. Press the **LOCK AXIS** soft key while the tool is still cutting. Retract from the current position. Turn the spindle off and measure the workpiece diameter. Enter the measured diameter or radius, and press **ENTER**. See Fig. I.24

Remember to ensure the 200S is in diameter display mode (Ø) if you input a diameter value.

Calling a Tool from the Tool Table

To call a tool, press the **TOOL** soft key. Use the UP/DOWN arrow keys to cursor through the selection of tools (1-16). Highlight the tool you want. Verify the proper tool has been called, and press the **C** key to exit.

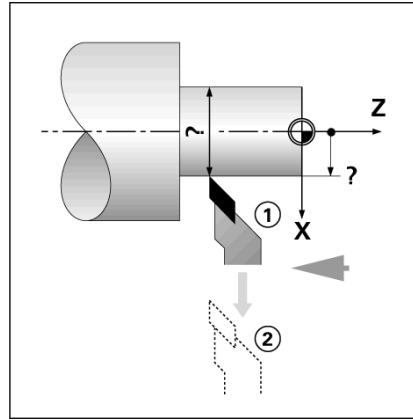

Fig. I.23 Setting Tool Offset

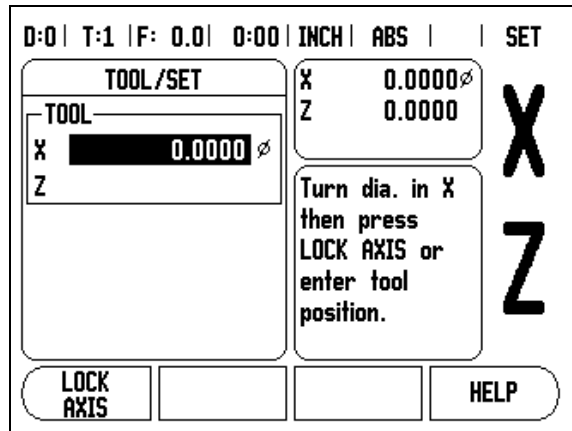

Fig. I.24 TOOL/SET Form

Datum Soft Key

See "Datum Soft Key" on page 8 for basic information. Datum settings define the relationships between the axis positions and the display values. For most lathe operations there is only one X-axis datum, the center of the chuck, but it may be helpful to define additional datums for the Z-axis. The table can hold up to 10 datum points. The easiest way to set datum points is to touch a workpiece at a known diameter or location, then enter that dimension as the value that the display should be showing

Example: Setting a workpiece datum. See Fig. I.25.

Preparation:

Call the tool data by selecting the tool which you are using to touch the workpiece. Press the **DATUM** soft key. The cursor will be in the DATUM NUMBER field. Enter the datum number and press the Down arrow key to go to the X-axis field. Touch the workpiece at point 1. Enter the radius or diameter of the workpiece at that point.

Remember to ensure the 200S is in diameter display mode (\emptyset) if you input a diameter value. Press the Down arrow key to advance to the Z axis.

Touch the workpiece surface at point 2. Enter the position of the tool tip (Z= 0) for the Z coordinate of the datum. Press **ENTER**.

Setting Datums using LOCK AXIS Function

The LOCK AXIS function is useful for setting a datum when a tool is under load and the diameter of the workpiece is not known. See Fig. I.26.

To use the LOCK AXIS function:

Press the **DATUM** soft key. The cursor will be in the DATUM NUMBER field. Enter the datum number and press the Down arrow key to go to the X axis field. Turn a diameter in the X axis. Press the **LOCK AXIS** soft key while the tool is still cutting. Retract from the current position. Turn the spindle off and measure the workpiece diameter. Enter the measured diameter, for example, 1.5" and press **ENTER**.

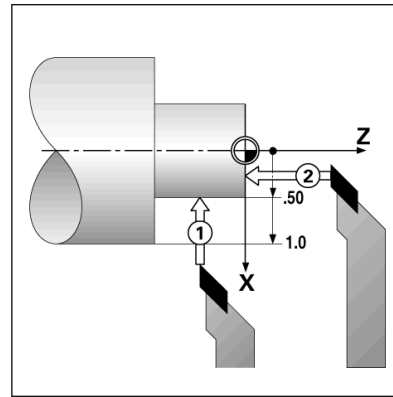

Fig. I.25 Setting a workpiece datum

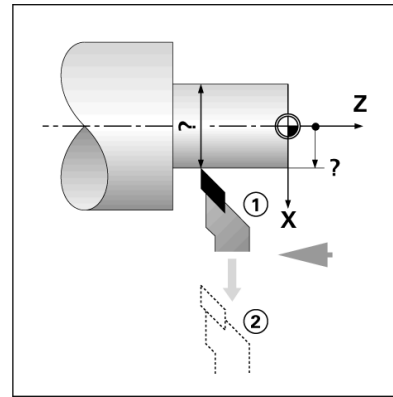

Fig. I.26

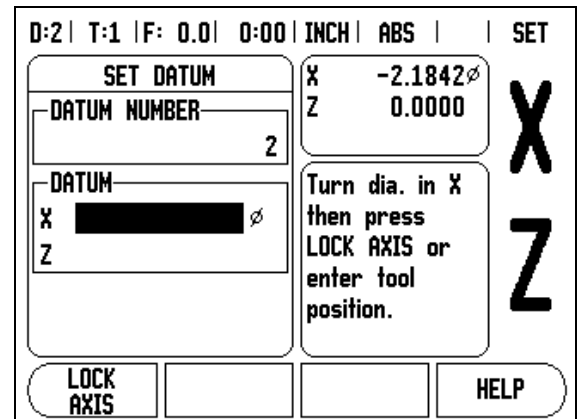

Fig. I.27 Setting Datum using LOCK AXIS

Preset Soft Key (Turning)

The functionality of the Preset soft key has been explained previously in this manual (See "Preset Soft Key" on page 10). The explanation and examples on those pages are based on a mill application. The basics of those explanations are the same for turning applications with two exceptions; Tool Diameter Offsets (R+/-), and Radius vs. Diameter inputs.

Tool diameter offsets have no applications with turning tools, so this functionality is not available while doing turning presets.

While doing turning, input values can be either radius or diameter values. It is important to be sure the units you are entering for the preset agree with the state that the display is currently using. A diameter value is shown with a Ø symbol. The state of the display can be changed using the **RAD/DIA** soft key (available in both operating modes).

Radius/Diameter Soft Key

Drawings for lathe parts usually give diameter values. 200S can display either the radius or the diameter for you. When the diameter is being displayed, the diameter symbol (Ø) is shown next to the position value. See Fig. I.28.

Example: Radius display, position 1, X = .50

Diameter display, position 1, X = 1.0Ø

Press the **RAD/DIA** soft key to switch between radius display and diameter display.

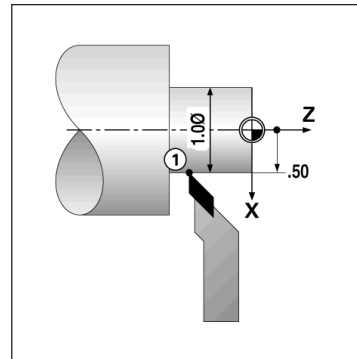

Fig. I.28 Workpiece for radius/diameter display

Vectoring

Vectoring breaks down the movement of the compound axis into the crossfeed or longitudinal axes. See Fig. I.29. If you are turning threads, for example, vectoring lets you see the diameter of the thread in the X-axis display, even though you are moving the cutting tool with the compound axis handwheel. With vectoring enabled, you can preset the desired radius or diameter in the X-axis, so that you can "machine to zero".



When vectoring is used, the top slide (compound) axis encoder must be assigned to the bottom display axis. The crossfeed component of movement of the axis will then be shown in the top display axis. The longitudinal component of movement of the axis will be shown in the middle display axis.

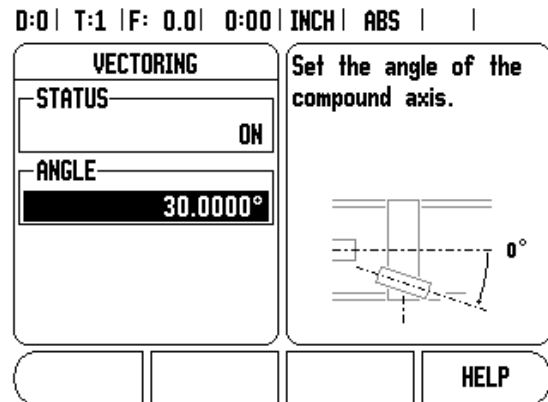

Fig. I.29 Vectoring

Select Vectoring from Job Setup.

Press the **ON** soft key to enable the vectoring feature.

Arrow down to the Angle field to enter the angle between the longitudinal slide and top slide with 0° indicating the top slide is moving parallel to the longitudinal slide. Press **ENTER**.

I – 3 Turning Specific Operations

II – 1 Installation Setup

Installation Setup Parameters

Installation setup is accessed by pressing the **SETUP** soft key, which brings up **INSTALLATION SETUP** soft key. See Fig. II.1.

Installation Setup parameters are established during the initial installation and, most likely, will not often change. For this reason, the installation setup parameters are protected by the passcode.

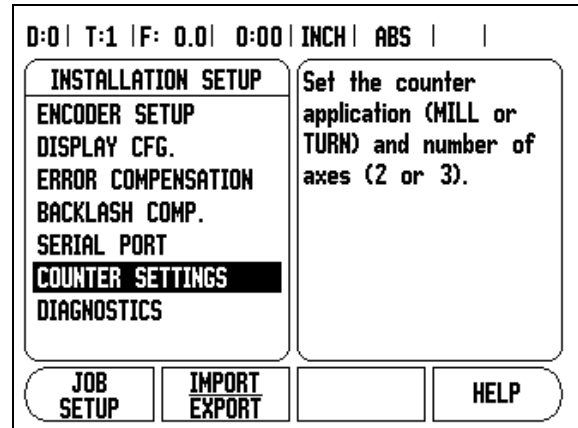

Fig. II.1 Installation screen

Encoder Setup

The ENCODER SETUP is used to set the encoder resolution and type (linear, rotary), count direction, reference mark type. See Fig. II.2.

- ▶ The cursor will default to the **ENCODER SETUP** field upon opening Installation Setup. Press **ENTER**. This opens a list of possible encoder inputs.
- ▶ Scroll to the encoder you want to change and press **ENTER**.
- ▶ Cursor will be in the ENCODER TYPE field, select the encoder type by pressing the **LINEAR/ROTARY** soft key.
- ▶ For linear encoders, cursor to the RESOLUTION field and use **COARSER** or **FINER** soft keys to select the encoder's resolution in μm (10, 5, 2, 1, 0.5) or type in the exact resolution. For rotary encoders, enter the number of counts per revolution.
- ▶ In the REFERENCE MARK field, toggling the **REF MARK** soft key select whether the encoder has no reference signal with **NONE**, single reference mark with the **SINGLE** or with the **P-TRAC** soft key for encoders with the Position-Trac™ feature.
- ▶ In the COUNT DIRECTION field, select the count direction by pressing the **POSITIVE** or **NEGATIVE** soft key. If the encoder's count direction matches the user's count direction, select positive. If the directions do not match, select negative.
- ▶ In the ERROR MONITOR field, select whether the system will monitor and display encoder errors by selecting **ON** or **OFF**. When an error message occurs, press the **C** key to remove it.

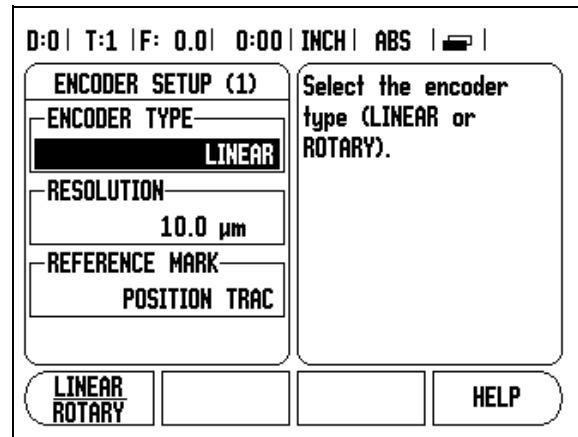

Fig. II.2 ENCODER SETUP form

Display Configuration

The DISPLAY CONFIGURATION form is where the operator determines which axes are displayed and in what order.

- ▶ Scroll to the desired display and press **ENTER**.
- ▶ Press the ON/OFF soft key to turn the display on or off. Press the Left or Right arrow key to select the axis label.
- ▶ Scroll to the INPUT field.
- ▶ Scroll to the DISPLAY RESOLUTION field. Press the **COARSER** or **FINER** soft keys to select the display resolution.

Coupling

- ▶ Press the numeric keys associated with the encoder input on the back of the unit. Press the **+** or **-** soft keys to couple a second input with the first. The input numbers are displayed next to the axis label indicating that the position is a coupled position (i.e. "2 + 3"). See Fig. II.4.

Z Coupling (turning applications only)

The 200S Turning application provides a quick method for coupling the Z₀ and Z axis position on a 3 axis system. The display can be coupled in either the Z or Z₀ displays. See Fig. II.3.

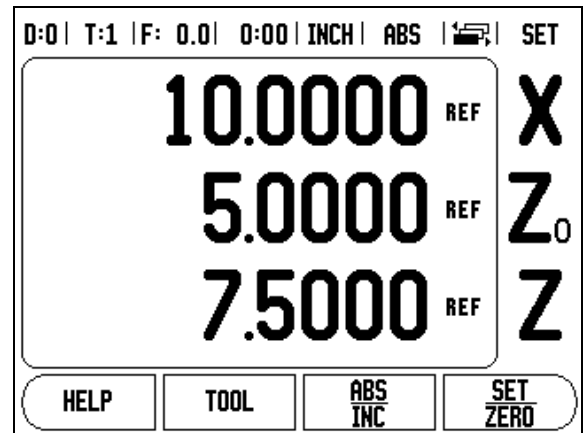

Fig. II.3 Normal Display form

Enabling Z Coupling

To couple the Z₀ and Z axis and have the result displayed on the Z₀ display, press and hold the Z₀ key approximately 2 seconds. The sum of the Z positions will be displayed on the Z₀ display and the Z display will be blanked. See Fig. II.4.

To couple the Z₀ and Z axis and have the result displayed on the Z display, press and hold the Z key for approximately 2 seconds. The sum of the Z positions will be displayed on the Z display and the Z₀ display will be blanked. The coupling is preserved in between power cycles.

Moving either Z₀ or Z inputs will update the coupled Z position.

When a position is coupled, the reference mark for both encoders must be found in order to recall the previous datum.

Disabling Z Coupling

To disable Z Coupling, press the axis key of the display that is blank. The individual Z₀ and Z display positions will be restored.

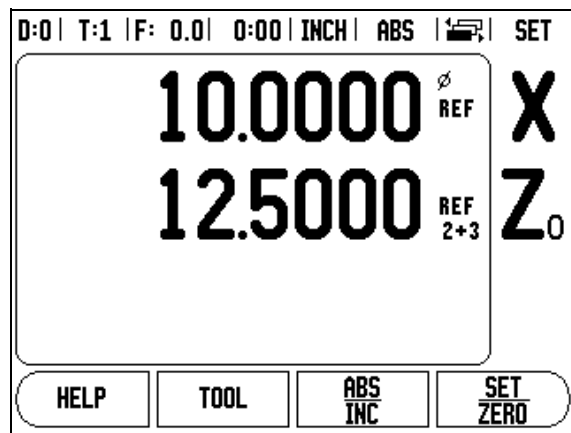

Fig. II.4 Enabling Z Coupling

Error Compensation

The distance a cutting tool travels, measured by an encoder, can in certain cases, differ from the actual tool travel. This error can occur due to ball screw pitch error or deflection and tilting of axes. This error can either be linear or non-linear. You can determine these errors with a reference measurement system, ex. gauge blocks, laser, etc. From an analysis of the error it can be determined which form of compensation is required, linear or non-linear error.

The 200S provides the opportunity to compensate for these errors and each axis can be programmed separately with the appropriate compensation.



Error compensation is only available when using linear encoders.

Linear Error Compensation

Linear error compensation can be applied, if the results of the comparison with a reference standard show a linear deviation over the whole measuring length. In this case the error can be compensated by the calculation of a single correction factor. See Fig. II.5 & Fig. II.6

- ▶ Once determined, the encoder's error information is entered directly. Press the **TYPE** soft key to select **LINEAR** compensation.
- ▶ Enter the compensation factor in parts per million (ppm) and press the **ENTER** key.

To calculate the linear error compensation use this formula:

$$\text{Correction factor LEC} = \left(\frac{S - M}{M} \right) \times 10^6 \text{ ppm}$$

with S = measured length with reference standard
M = measured length with device at axis

Example

If the length of the standard you used is 500 mm and the measured length along the X-axis is 499.95, then the LEC for the X-axis is 500 parts per million (ppm).

$$\text{LEC} = \left(\frac{500 - 499.95}{499.95} \right) \times 10^6 \text{ ppm}$$

LEC = 100 ppm
(rounded to the nearest whole number)

Fig. II.5 Linear error comp., calculation formula

Non-Linear Error Compensation

Non-linear error compensation should be applied, if the results of the comparison with a reference standard show an alternating or oscillating deviation. The required correction values are calculated and entered in a table. 200S supports up to 200 points per axis. The error value between two entered adjacent correction points is calculated with linear interpolation.



Non-linear error compensation is only available on scales with reference marks. If non-linear error compensation has been defined, no error compensation will be applied until the reference marks have been crossed.

Starting a Non-linear Error Compensation Table

- ▶ Select Non-linear by pressing the **TYPE** soft key.
- ▶ To start a new error compensation table, first press the **EDIT TABLE** soft key.
- ▶ All correction points (up to 200) are equally spaced from the start point. Enter the distance between each of the correction points. Press the Down arrow key.
- ▶ Enter the table's start point. The start point is measured from the scale's reference point. If this distance is not known, you can move to the location of the start point and press **TEACH POSITION**. Press **ENTER**.



Pressing **ENTER** will save the spacing and start point information. Any previous data in the table will be erased.

D:0 T:1 F: 0.0 0:00 INCH ABS			
ERROR COMPENSATION		Error compensation for this input is OFF.	
INPUT X1	0 PPM	Press TYPE to select linear or non-linear error compensation.	
INPUT X2	OFF		
INPUT X3	OFF		
TYPE [OFF]			HELP

Fig. II.6 Linear error compensation form

Configuring the Compensation Table

- ▶ Press the **EDIT TABLE** soft key to view the table entries.
- ▶ Use the Up or Down arrow keys or the numeric keys to move the cursor to the correction point to be added or changed. Press **ENTER**.
- ▶ Enter the known error which exists at this point. Press **ENTER**.
- ▶ When completed, press **C** key to exit the table and return to the Error Compensation form.

Reading the Graph

The error compensation table may be viewed in table or graphical formats. The graph shows a plot of a translation error vs. measured value. The graph has a fixed scale. As the cursor is moved through the form, the location of the point on the graph is indicated with a vertical line.

Viewing the Compensation Table

- ▶ Press the **EDIT TABLE** soft key.
- ▶ To switch between the table and graph views, press the **VIEW** soft key.
- ▶ Press the Up or Down arrow keys or the numeric keys to move the cursor within the table.

The error compensation table data may be saved to or loaded from a PC via the serial port.

Exporting the Current Compensation Table

- ▶ Press the **EDIT TABLE** soft key
- ▶ Press the **IMPORT/EXPORT** soft key.
- ▶ Press the **EXPORT TABLE** soft key.

Importing a New Compensation Table

- ▶ Press the **EDIT TABLE** soft key.
- ▶ Press the **IMPORT/EXPORT** soft key.
- ▶ Press the **IMPORT TABLE** soft key.

Backlash Compensation

When using a rotary encoder with a lead screw, a change in direction of the table might cause an error in the displayed position due to clearances within the lead screw assembly. This clearance is referred to as backlash. This error can be compensated for by inputting the amount of backlash within the lead screw into the Backlash Compensation feature. See Fig. II.7.

If the rotary encoder is ahead of the table (displayed value is greater than the table's true position), this is called positive backlash and the value entered should be the positive value of the amount of error.

No Backlash Compensation is 0.000.

Fig. II.7 Backlash compensation form

Serial Port

A printer or computer may be connected to the serial port. Job and installation setup parameters may be sent to a printer or computer. Remote commands, remote key codes and job and installation setup parameters may be received from a computer. See Fig. II.8.

- ▶ The BAUD field can be set to 300, 600, 1 200, 2 400, 9 600, 19 200 38 400 57 600 or 115 200 by using the **LOWER** and **HIGHER** soft keys.
- ▶ The parity can be set to NONE, EVEN, or ODD using the soft key provided.
- ▶ Data Bits in the FORMAT field can be set to 7 or 8 using the soft key provided.
- ▶ The STOP BITS field can be set to 1 or 2 using soft key.
- ▶ LINE FEED field can be set to YES if the external device needs a line feed to follow a carriage return.
- ▶ Output tail is the number of carriage returns that will be sent at the end of the measured value output transmission. The output tail is initially 0 and can be set to a positive integer value (0 - 9) by using the numeric hard keys.

The serial port settings will be retained on a power cycle. There is no parameter to enable or disable the serial port. Data will only be sent to the serial port if the external device is ready. Refer to Data Interface section for cable connection and pin assignments.

Fig. II.8 SERIAL PORT form

Counter Settings

The COUNTER SETTINGS feature is the parameter where the operator defines the user application for the readout. The choices are for milling or turning applications. See Fig. II.9.

A **FACTORY DEFAULT** soft key appears in the COUNTER SETTINGS choice of options. When pressed, the configuration parameters (based on either mill or turn) will be reset to factory defaults. The operator will be prompted to press **YES** to set parameters to factory default settings or **NO** to cancel and return to previous menu screen.

The Number of Axes field sets the number of axes needed. A **2/3** soft key will appear to choose between either 2 or 3 axes.

The Position Recall feature, when it is "ON", will store the last position of each axis when power was turned off and then redisplay that position once power is turned back on.



Note that any movement that occurs while power is off will be lost. Whenever power has been off it is recommended to re-establish workpiece datums using the Reference Mark Evaluation procedure. See "Reference Mark Evaluation" on page 2.

Fig. II.9 COUNTER SETTINGS form

Diagnostics

The DIAGNOSTICS menu provides access for testing the keypad and edge finders. See Fig. II.10.

Keypad Test

An image of the keypad provides an indication when a switch is pressed and released.

- ▶ Press each hard and soft key to test. A dot will appear on each key when it has been pressed indicating that it is operating properly.
- ▶ Press the C key two times to exit the keypad test.

Edge Finder Test

- ▶ To test the edge finder, touch the edge finder to a part and * will appear on the display screen when a grounding type edge finder is used. * will appear when an electronic edge finder is used.

Display Test

- ▶ To test the display, press the enter key to set the display to solid black, solid white, and back to normal.

Fig. II.10 DIAGNOSTICS form

II – 2 RS-232C Serial Communications

Serial port

The RS-232-C/V.24 serial port is located on the rear panel. The following devices can be connected to this port (see "Pin assignment" on page 31):

- Printer with serial data interface
- Personal computer with serial data interface

For operations that support data transfer, an **IMPORT/EXPORT** soft key will be available. (See "Serial Port" on page 26).

To export data to a serial port printer, press the **IMPORT/EXPORT** soft key. The data is exported in an ASCII text format which can be printed directly.

To export or import data between the 200S and a personal computer, the PC can use a common terminal communications software such as Hyperterminal. This software processes the data being sent or received over the serial cable link. All data transferred between 200S and the PC is in ASCII text format.

To export data from the 200S to a PC, the PC must first be made ready to receive the data to save it to a file. Setup the terminal communication program to capture ASCII text data from the COM port to a file on the PC. After the PC is ready to receive, start the data transfer by pressing the 200S **IMPORT/EXPORT** soft key.

To import data into the 200S from a PC, the 200S must first be made ready to receive the data. Press the 200S **IMPORT/EXPORT** soft key. After the 200S is ready, setup the terminal communications program on the PC to send the desired file in ASCII text format.



The 200S does not support communication protocols such as Kermit or Xmodem.

II – 3 Installation and Electrical Connections

Installation

M6 screws are used to secure 200S from below. For the hole locations: See "Dimensions" on page 34.

Electrical requirements

Voltage 100 - 240 Vac

Power 30 VA max.

Frequency 50/60 Hz (+/- 3Hz)

Fuse 630 mA/250 Vac, 5 mm x 20 mm, Slo-Blo (line and neutral fused)

Environmental

Operating temperature 0° to 45°C (32° to 113°F)

Storage temperature -20° to 70°C (-4° to 158°F)

Mechanical weight 2.6 kg (5.8 lb.)

Protective earthing (grounding)



It is necessary to connect the protective conductor terminal on the rear panel to the star point of machine ground (see Fig. II.11).

Preventative maintenance

No special preventative maintenance is necessary. For cleaning, wipe lightly with a dry lint-free cloth.

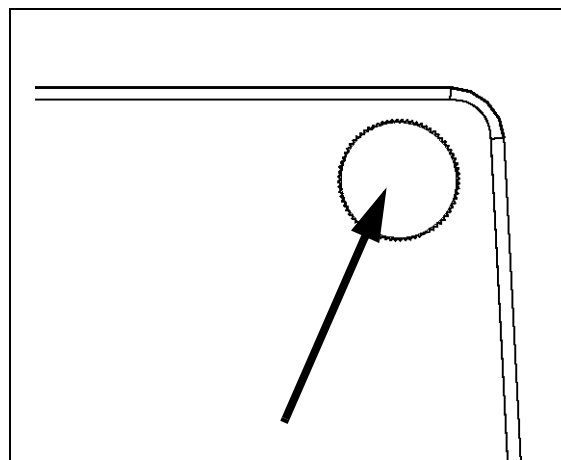

Fig. II.11 The protective conductor terminal on the upper corner on rear panel.

II – 4 I/O Connections

Encoders are plugged into connectors marked Inputs 1, 2, 3.

Pin layout for Electronic Edge Finder (See Fig. II.12 for pinout)

Pin	Assignment
1	0V (Inner shield)
2	Stand By
3	
6	+5V
7	
8	0V
9	
12	
13	Switch Signal
14	
15	
Housing	External Shield

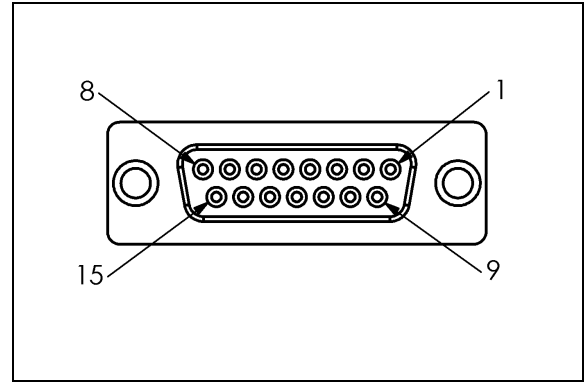

Fig. II.12 15 pin receptacle connector for Edge Finder

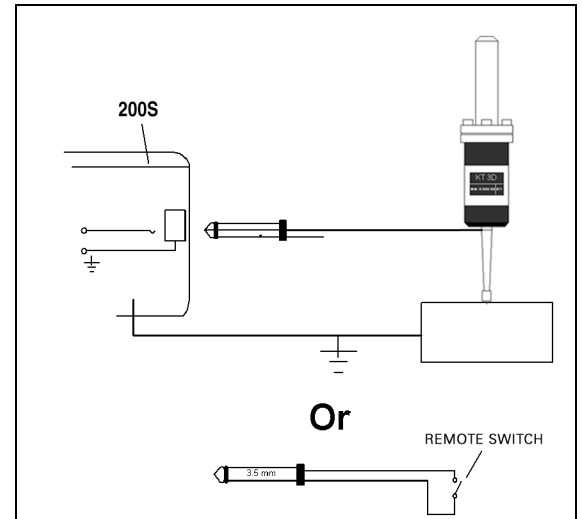

Fig. II.13 Grounding Edge Finder/Remote Switch

Wiring the serial communication cable

The wiring of the serial communication cable depends on the device being connected (see technical documentation for external device). See Fig. II.14, Fig. II.15, & Fig. II.16.

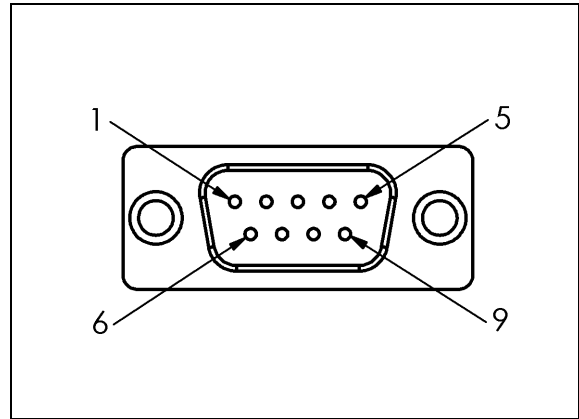

Fig. II.14 Pin layout of RS-232-C/V.24 data interface

Pin assignment

Pin	Assignment	Function
1	No assignment	
3	TXD	- Transmitted data
2	RXD	- Received data
7	RTS	- Request to send
8	CTS	- Clear to send
6	DSR	- Data set ready
5	SIGNAL GND	- Signal ground
4	DTR	- Data terminal ready
9	No assignment	

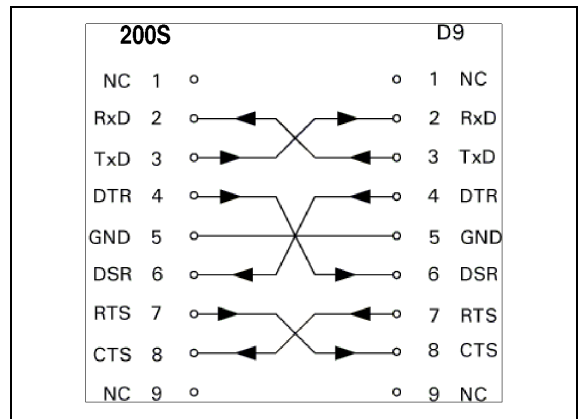

Fig. II.15 Pin connection for serial port with handshaking

Signal

Signal	Signal level "1"= "active"	Signal level "0"= "inactive"
TXD, RXD	-3 V to -15 V	+ 3 V to + 15 V
RTS, CTS DSR, DTR	+ 3 V to + 15 V	-3 V to -15 V

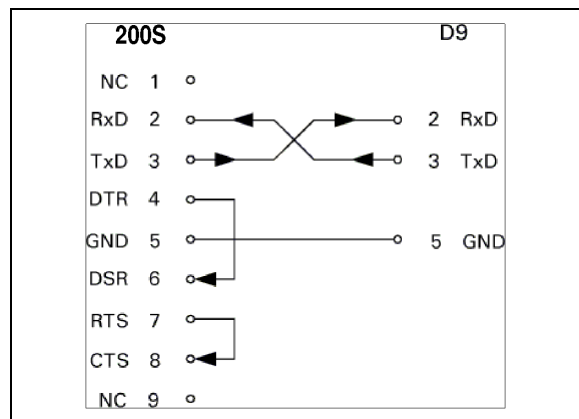

Fig. II.16 Pin connection for serial port without handshaking

II – 5 Remote Switch Data Output

The remote switch (pendant or footswitch) or **Ctrl B** (sent over serial interface) will transmit the currently displayed values in either Actual Value or Distance-To-Go mode, whichever is currently visible.

Data output using external signals

Example 1: Linear axis with radius display X = + 41.29 mm

X	=	+	4 1	.	2 9		R	<CR>	<LF>
1	2	3	4	5	6	7	8	9	10

- 1 Coordinate axis
- 2 Equal sign
- 3 +/- sign
- 4 2 to 7 places before the decimal point
- 5 Decimal point
- 6 1 to 6 places after the decimal point
- 7 Unit: blank space for mm, " for inches
- 8 Actual value display:
R for radius, D for diameter
- Distance-to-go display:
r for radius, d for diameter
- 9 Carriage return
- 10 Blank line (Line Feed)

Example 2: Rotary axis with degrees decimal display C = + 1260.0000°

C	=	+	1 2 6 0	.	0 0 0 0		W	<CR>	<LF>
1	2	3	4	5	6	7	8	9	10

- 1 Coordinate axis
- 2 Equal sign
- 3 +/- sign
- 4 4 to 8 places before the decimal point
- 5 Decimal point
- 6 0 to 4 places after the decimal point
- 7 Blank space
- 8 W for angle (in distance-to-go display: w)
- 9 Carriage return
- 10 Blank line (Line Feed)

Example 3: Rotary axis with degrees/minutes/seconds display C = + 360° 23' 45" '

C	=	+	3 6 0	:	2 3	:	4 5		W	<CR>	<LF>
1	2	3	4	5	6	7	8	9	10	11	12

- 1 Coordinate axis
- 2 Equal sign
- 3 +/- sign
- 4 3 to 8 places degrees
- 5 Colon
- 6 0 to 2 places minutes
- 7 Colon
- 8 0 to 2 places seconds
- 9 Blank space
- 10 W for angle (in distance-to-go display: w)
- 11 Carriage return
- 12 Blank line (Line Feed)

Data output using Edge Finder

In the next three examples, measured value output is started with a **switching signal from the edge finder**. Printing capability can be turned on or off in the Job Setup parameter Measured Value Output. Information from here is transmitted from the selected axis.

Example 4: Probing function Edge Y = -3674.4498 mm

Y	:	-	3	6	7	4	.	4	4	9	8	R	<CR>	<LF>
1	2	3	4	5	6	7	8	9	10	11				

- 1 Coordinate axis
- 2 2 blank spaces
- 3 Colon
- 4 +/- sign or blank space
- 5 2 to 7 places before the decimal point
- 6 Decimal point
- 7 1 to 6 places after the decimal point
- 8 Unit: blank space for mm, " for inches
- 9 R for radius display, D for diameter display
- 10 Carriage return
- 11 Blank line (Line Feed)

Example 5: Probing function Centerline

Coordinate of centerline on X axis CLX = + 3476.9963 mm (Center Line X axis)

Distance between the probed edges DST = 2853.0012 mm (Distance)

CLX	:	+	3	4	7	6	.	9	9	6	3	R	<CR>	<LF>
DST	:		2	8	5	3	.	0	0	1	2	R	<CR>	<LF>
	1	2	3	4	5	6	7	8	9					

- 1 Colon
- 2 +/- sign or blank space
- 3 2 to 7 places before the decimal point
- 4 Decimal point
- 5 1 to 6 places after the decimal point
- 6 Unit: blank space for mm, " for inches
- 7 R for radius display, D for diameter display
- 8 Carriage return
- 9 Blank line (Line Feed)

Example 6: Probing function Circle Center

First center point coordinate, e.g. CCX = -1616.3429 mm, Second center point coordinate, e.g. CCY = +4362.9876 mm, (Circle Center X axis, Circle Center Y axis; coordinates depend on working plane)
Circle diameter DIA = 1250.0500 mm

CCX	:	-	1	6	1	6	.	3	4	2	9	R	<CR>	<LF>
CCY	:	+	4	3	6	2	.	9	8	7	6	R	<CR>	<LF>
DIA	:		1	2	5	0	.	0	5	0	0	R	<CR>	<LF>
	1	2	3	4	5	6	7	8	9					

- 1 Colon
- 2 +/- sign or blank space
- 3 2 to 7 places before the decimal point
- 4 Decimal point
- 5 1 to 6 places after the decimal point
- 6 Unit: blank space for mm, " for inches
- 7 R for radius display, D for diameter display
- 8 Carriage return
- 9 Blank line (Line Feed)

II – 6 Dimensions

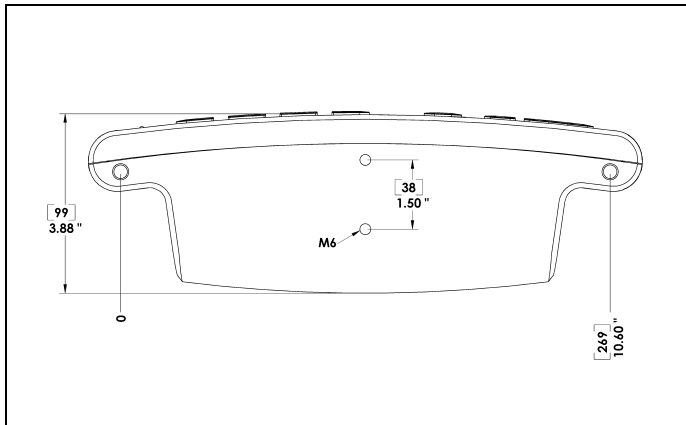
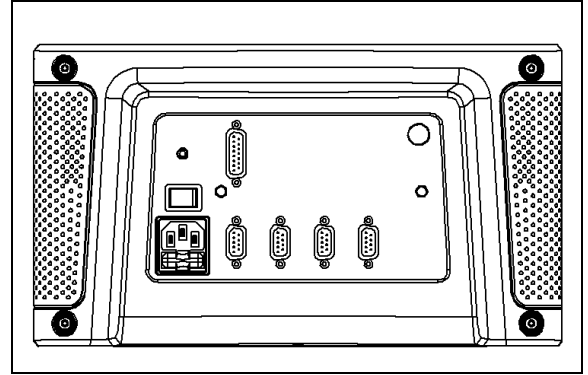
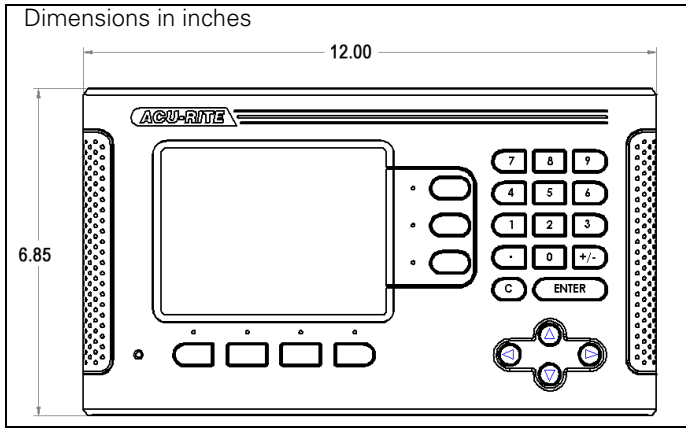

Index

A

Absolute Distance Preset 10
Actual Value/Distance-To-Go soft key 2
Axis Labels 1

B

Backlash Compensation 26

C

Console adjustment 5
Counter Settings 23
Coupling 22

D

Data Interface 28
Datum setting without probing function 18
Datum soft key 8
Datum Soft Key (Turning) 18
Diagnostics 27
Diameter Axes (Turning) 4
Dimensions 35
Disable Ref soft key 3
Display Area 1
Display configuration 22

E

Edge Finder 3
Electrical Requirements 29
Enable Ref soft key 2
Enable/Disable Ref Function 3
Encoder Setup 21
Environmental specs. 29
Error Compensation 23

G

General Operation's Soft Key Function Detailed 6

I

I/O Connections 30
Import/Export (setting) 6
Incremental Distance Preset 12
Installation Setup Parameters 21

J

Job Clock 4
Job Setup Parameters 3

L

Language (setting) 5
Layout of Screen 1
Linear Error Compensation 24
Linear Pattern 15

M

Measured Value Output 32
Measured Value Output (setting) 4
Milling Specific Operations and Soft Key
Functions Detailed 7
Mirror 3

N

Near Zero Warning 4
No Ref soft key 2
Non-Linear Error Compensation 24

O

Operating Modes 2

P

Patterns (Milling) 13
Position Recall 27
Preset 10
Preset Soft Key (Turning) 19
Preventative Maintenance 29
Protective Earthing (Grounding) 29

R

Radius/Diameter display 19
Ref Symbols 1
Reference Mark Evaluation 2
Reference marks 2
Remote Switch 5
Remote Switch (setting) 5

S

Scale factor 3
Serial Port 26
Set Zero soft key 6
Soft key Labels 1
Status Bar 1
Status Bar (setting) 4

T

Tool setting, turning 16
Tool soft key 7
Tool soft key (Turning) 16

U

Units of measurement, setting 3

V

Vectoring 19

Z

Z Coupling 22

Acu-Rite Companies Inc.
is an
ISO 9001
CERTIFIED
MANUFACTURER



Acu-Rite Companies, Inc.
One Precision Way • Jamestown, NY 14701

