



HEIDENHAIN



Digital Readouts

Linear Encoders

for Manually Operated
Machine Tools

February 2006

Digital readouts from HEIDENHAIN are used in a wide variety of applications, including machine tools, infeed axes (e.g. on saws and presses), measuring and inspecting equipment, dividing apparatuses, setting tools, and measuring stations for production control. In order to meet the requirements of these applications, many encoders from HEIDENHAIN can be connected to the digital readouts.

The main application for digital readouts, however, is on manually operated machine tools. Whether milling, drilling, boring or turning, the praxis-oriented cycles provide the operator with optimal support. Digital readouts show the current position quickly and clearly, enabling a significant increase in work productivity. The most important linear encoders for position capture on manually operated machine tools are also listed in this brochure.

You can find other encoders for connection to the digital readouts on the Internet under www.heidenhain.de, or in the *Linear Encoders for NC-Controlled Machine Tools*, *Length Gauges*, *Angle Encoders* and *Rotary Encoders* product brochures.



Content

Digital Readouts

Overview	Digital Readouts from HEIDENHAIN	4
	Selection Guide	6
Features	Functions of the ND 200 Series	8
	Functions of the ND 780 and POSITIP 880	10
	Programming Function of the POSITIP	15
Specifications	ND 200 Series – Universal Digital Readouts for One Axis	16
	ND 780 – Adaptable Digital Readout for up to Three Axes	18
	POSITIP 880 – Programmable Digital Readout for up to Six Axes	20
Mounting		22
Electrical Connection	Encoders	24
	Interfaces	26
	Encoders	27
	RS-232-C/V.24	27
	BCD	28
	Switching Inputs	29
	Switching Outputs for ND 200	30
	Switching Outputs for POSITIP 880 – IOB 89	31

Linear Encoders for Manually Operated Machine Tools

Overview		32
Specifications	LS 388 C	33
	LS 603	
Dimensions	LS 388 C	34
	LS 603	35
Mounting		36
Electrical connection		37

Digital Readouts from HEIDENHAIN

– Designed for the Real World

HEIDENHAIN digital readouts have universal application: In addition to standard tasks on milling, drilling and boring machines and lathes, they also offer ideal solutions for many applications on machine tools, measuring and testing equipment, and special machines—in fact all machines where axis slides are traversed manually.



Versatile, ergonomic, and well-planned

Digital readouts from HEIDENHAIN are designed to be highly user-friendly.

Typical features:

- Highly readable graphic display (alphanumeric display on the ND 200).
- Simple, logically arranged keypad helps you quickly master the available functions and enter positions reliably and rapidly.
- Ergonomically designed push-button keypad with symbols that withstand years of use.
- Splash-protected front panel prevents coolant from damaging your digital readout.
- Sturdy cast-metal housing built for the worst of day-to-day workshop conditions.



– Operational Advantages

Fast

HEIDENHAIN's digital readouts save time. The distance-to-go display feature allows the user to approach the next nominal position quickly and reliably, simply by traversing to a display value of zero. Reference points can be set wherever needed. This simplifies positioning, especially for workpieces with complicated dimensions.

When milling or boring hole patterns or rectangular pockets, the geometric data can be entered simply and quickly. The positions are approached directly using the distance-to-go display.

On lathes, the sum display feature for saddle and top slide contributes to more accurate positioning. If taper dimension data are not complete, the display will help the operator to calculate the angles.

The POSITIP is ideal for small-batch production, because repetitive machining sequences can be stored as programs and then used as often as required.

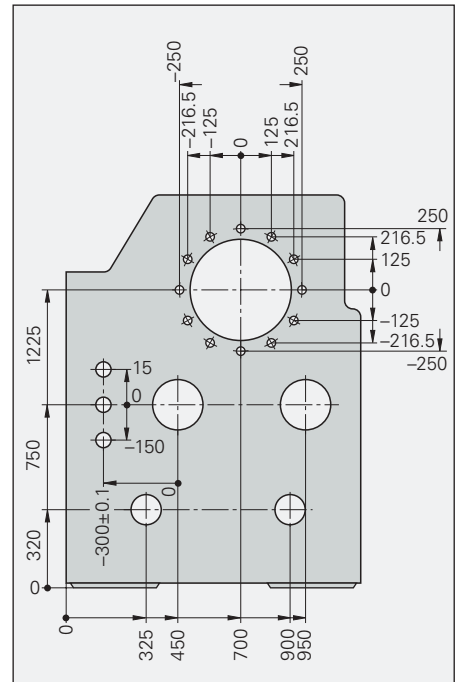

Reliable

A highly readable display shows the measured positions with respect to the selected reference point. As a result, the probability of error is reduced and machining becomes more reliable.

The graphic positioning aid of the POSITIP and ND 780 improves the speed and reliability of the distance-to-go display. Input of geometric data is made easy with the graphic display function.

Accurate

On older machine tools, precise machining in the range of 0.01 mm (0.0005 in.) is a matter of luck, since worn machine elements make exact dial and vernier settings impossible.

Linear encoders from HEIDENHAIN sense machine slide movement directly. The backlash caused by mechanical transfer elements such as lead screws, racks and gears therefore has no influence. By determining the slide position directly, you achieve higher machining accuracy and reduce scrap rates.



Selection Guide

ND 200 Series

Position and measured value displays for measuring devices, adjustment and testing equipment, automated tasks, as well as simple infeed and positioning tasks with **one axis**

- Switching inputs/outputs
- Special functions

Number of axes	Display	Reference points	Features
1	Length	2	–
	Length, Angle	2	<ul style="list-style-type: none"> • Sorting and tolerance check mode • Minimum/maximum display
	Length	2	
	Length	2	<ul style="list-style-type: none"> • Sum/difference display • Sorting and tolerance check mode

ND 780

Digital readout for milling, drilling and boring machines, as well as lathes, with **up to three axes**

- Monochrome flat-panel display
- Graphic support and help functions
- Dialog-supported user guidance

Number of axes	Display	Reference points/ Tool data	Features
Up to 3	Length, Angle	10 reference points; 16 tools	<p><i>Miscellaneous:</i></p> <ul style="list-style-type: none"> • Distance-to-go display <p><i>Milling and drilling:</i></p> <ul style="list-style-type: none"> • Probing functions for KT edge finder • Hole patterns (circular and linear patterns) • Tool-radius compensation <p><i>Turning:</i></p> <ul style="list-style-type: none"> • Radius/diameter display • Separate and sum display

POSITIP 880

Digital readout for milling, drilling and boring machines with **up to six axes**, as well as lathes

- Color flat-panel display
- Graphic support and help functions
- Program memory
- Dialog-supported user guidance

Number of axes	Display	Reference points/ Tool data	Features
Up to 6	Length, Angle	<p><i>Milling and drilling:</i></p> <p>99 reference points; 99 tools</p> <p><i>Turning:</i></p> <p>1 reference point; 99 tools</p>	<p><i>Miscellaneous:</i></p> <ul style="list-style-type: none"> • Distance-to-go display with graphic positioning aid • Programming of max. 999 program blocks per program <p><i>Milling and drilling:</i></p> <ul style="list-style-type: none"> • Probing functions for KT edge finder • Hole patterns (circular and linear patterns) • Roughing of rectangular pockets • Tool-radius compensation <p><i>Turning:</i></p> <ul style="list-style-type: none"> • Turning with allowances • Multipass cycles • Taper calculator • Radius/diameter display • Separate and sum display

Encoder inputs	Switching inputs/ outputs	Data interface	Model	Page
~ 11 μ App	–	–	ND 221 B	16
~ 1 V _{PP} ~ 11 μ App	Yes	RS-232-C/V.24	ND 281 B	
~ 11 μ App	Yes	BCD	ND 282 B	
~ 11 μ App	Yes	RS-232-C/V.24	ND 231 B	



Encoder inputs	Switching inputs/ outputs	Data interface	Model	Page
~ 1 V _{PP} ~ 11 μ App	<ul style="list-style-type: none"> • For KT edge finder • For edge finder with contact triggering 	RS-232-C/V.24	ND 780	18



Encoder inputs	Switching inputs/ outputs	Data interface	Model	Page
~ 1 V _{PP} ~ 11 μ App EnDat 2.1	<ul style="list-style-type: none"> • For KT edge finder • Additional via IOB 99 	RS-232-C/V.24; Centronics	PT 880	20



Functions of the ND 200 Series

Display freeze

A specific position value can be held in the display as long as desired. The true position value is counted internally until a fresh display value is called.

- **Frozen display** — the display value is frozen by the first latching signal. Every further latch signal updates the display to the current measured value, and the display **remains frozen** at the new value.

- **Frozen/concurrent display** — the display freezes only as long as the latch signal is present. With the signal off, the display shows the current measured values.

The Display Freeze feature operates in one of two modes:

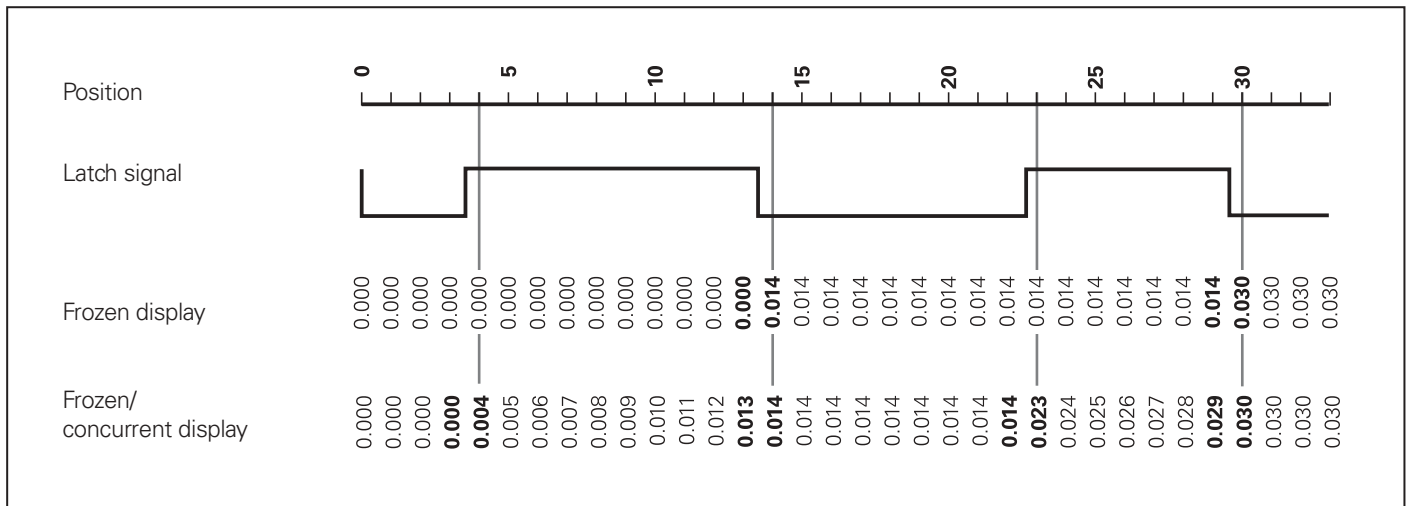

Minimum/maximum value storage

The **ND 281 B** and **ND 282 B** display units can store the minimum and maximum values from a series of measurements. When such a series is started — either via MOD key or through a switching input at the D-sub connection — the display stores the first measured value as the minimum and maximum values. Every 0.55 ms the display then compares the current measured value with the values in memory; it stores a new value if the measurement is greater than the stored maximum or less than the stored minimum value. At the same time the display also calculates and stores the difference (DIFF) of the MIN and MAX values.

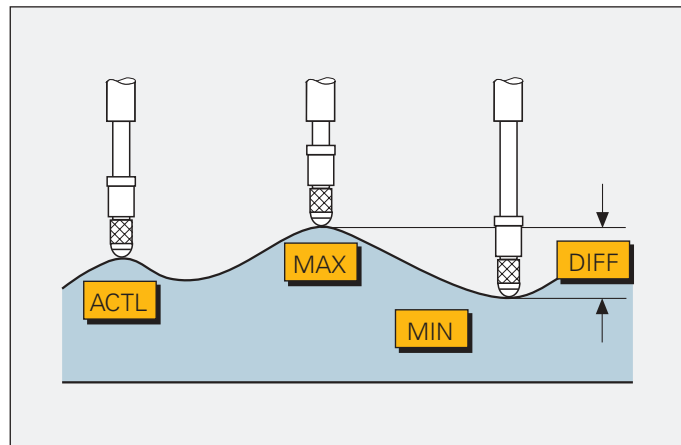

The minimum, the maximum, the difference between the two values, or the current measured value can be called either via the keypad or through a switching input of the D-sub connection. When a new series is started, the internal MIN/MAX/DIFF memory is automatically reset.

Sum/difference display

The **ND 231 B** has two length gauge inputs. The ND 231 B calculates the sum or difference of the two measured values and displays the result. The measured values from the two length gauges can also be displayed individually. The desired mode is selected either via keypad (in the operating parameters) or through the switching inputs.

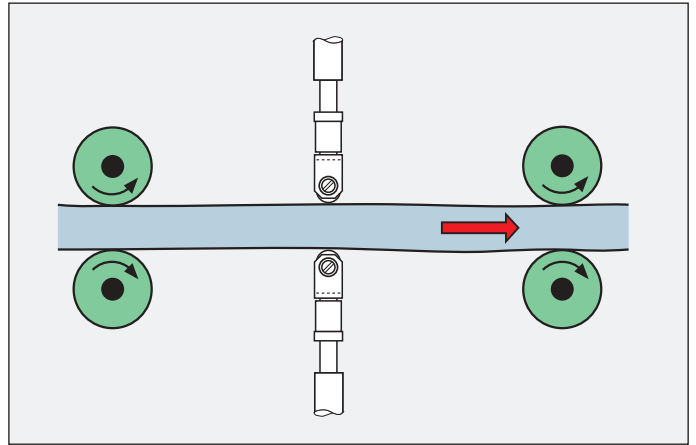

Sorting and tolerance check mode

The **ND 231 B**, **ND 281 B** and **ND 282 B** can inspect parts for compliance with tolerances and sort them into groups. To sort the parts, the display unit compares the displayed measured value with an upper and lower limit value previously entered with the keypad. The result of the evaluation (whether the measured value is below, above or within tolerance) is indicated in the status display with one of the symbols <, = or >. In addition, a corresponding signal is available at the switching outputs (D-sub). This information can also be output through the data interface.

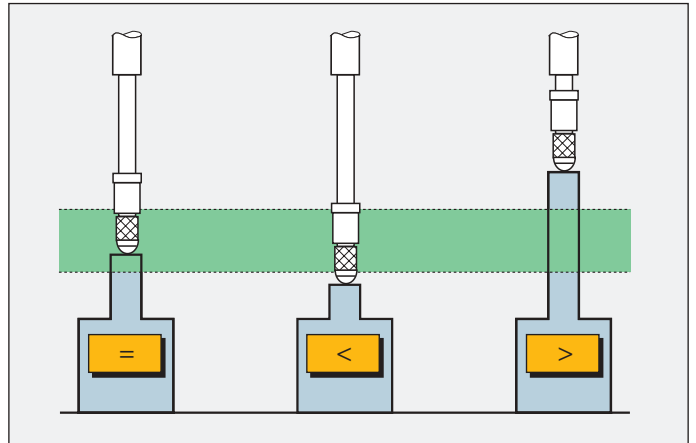

Angle display with the ND 281 B

The ND 281 B display unit can be switched by parameter to angle display. It presents angle values either in decimal degrees or in degrees, minutes, seconds. The angle display range can extend from $-\infty$ to $+\infty$, from 0° to 360° or from -180° to $+180^\circ$.

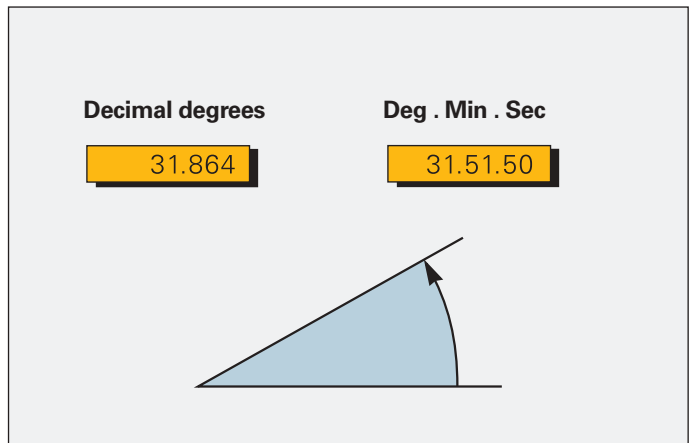

Functions of the ND 780 and POSITIP 880

– Convenient Setting of Reference Points

Easy setup with probing functions

A very useful accessory for setting reference points is the HEIDENHAIN KT edge finder. Simply move the edge finder toward a side of the workpiece until the stylus deflects. The counter automatically stores the exact position, taking into account the direction of approach and the radius of the stylus. In milling machine mode, the ND 780 and POSITIP digital readouts offer the following probe functions:

- Workpiece edge as reference point
- Workpiece centerline as reference point
- Circle center as reference point

For electrically conductive workpieces, these functions are also possible on the ND 780 with an edge finder with contact triggering.

Reference-point setting with the tool

The probe functions can also be carried out with the tool.

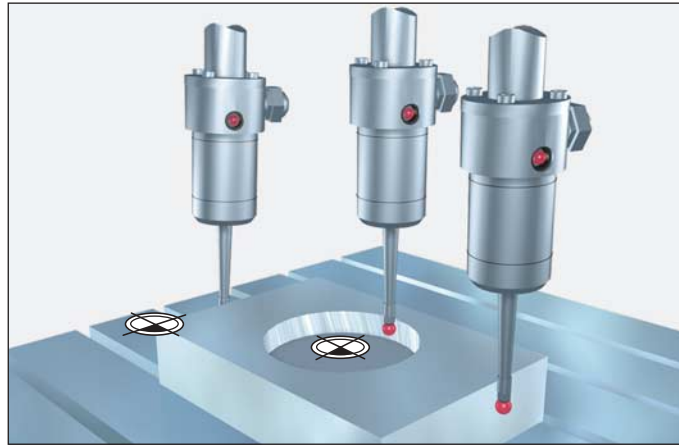

Accessory: KT edge finder

The KT is a 3-D triggering edge finder. The cylindrical stylus is spring-mounted in the edge finder housing. The stylus is deflected when it contacts the workpiece, and the edge finder sends a triggering signal over the connecting cable to the ND or the POSITIP.

The KT edge finder allows you to set reference points quickly and easily, without leaving marks on the workpiece.

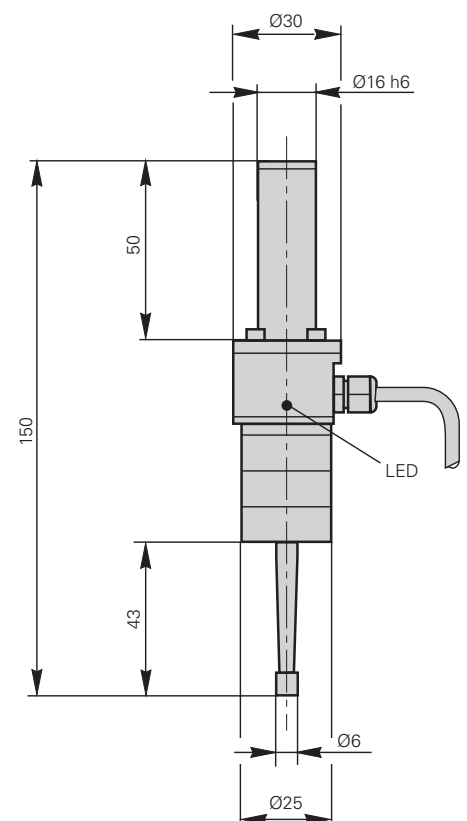

- Tool Compensation

Tool compensation with milling machines

The digital readouts can save the data of the tools used: The ND 780 stores the diameter, and POSITIP also stores the length and axis. The POSITIP 880 features a tool table for 99 tools, in which the data of pre-set tools or tool data determined on the machine can be stored.

When positioning in distance-to-go mode, the readouts take the tool radius (R+ or R-) in the machining plane into account, and the POSITIP also considers the tool length (ΔL) in the spindle axis.

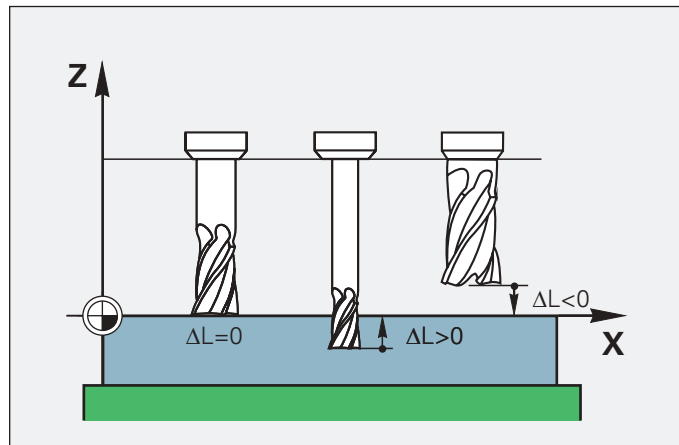
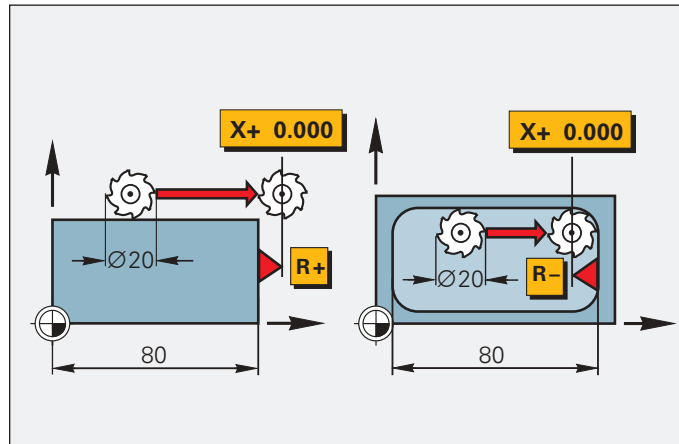

Determining and storing tool compensation values on lathes

With the ND 780 (16 tools) and POSITIP (99 tools) readouts, you can store the dimensional data for the tools you insert in the turret or quick-change holder:

- Enter the tool position directly when turning the first diameter, or
- "Freeze" the current axis display value, retract the tool, measure the turned diameter and then enter that value.

Changing reference points

If you change the workpiece or the reference point, you can set the new reference point without having to change the stored tool-offset values. The tool data are automatically referenced to the new reference point.

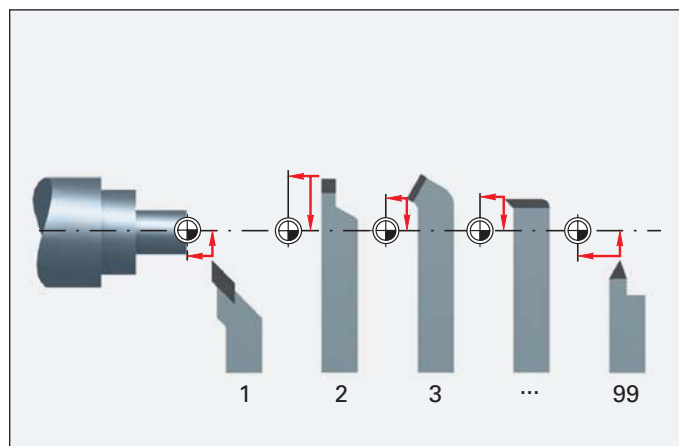

Functions of the ND 780 and POSITIP 880

– Distance-To-Go Display and Contour Monitoring

Distance-to-go display for turning and milling

The distance-to-go display feature of the ND 780 and POSITIP simplifies your work considerably. You enter the next nominal position, and the display shows you the distance remaining to the target position. You simply traverse to the display value zero.

The displays for milling can also compensate the cutter radius. You can machine your parts directly from the drawing dimensions without having to do any calculations, and there's no need to remember complicated numbers.

On POSITIP, the distance-to-go display is enhanced by a graphic positioning aid: As you traverse to zero, a square cursor moves into a target fork. If you prefer (e.g. for turning), POSITIP can show the absolute position value instead of the graphic.

POSITIP's distance-to-go display

With POSITIP, **oversizes** can be taken into consideration when turning. Simply enter the oversize value and traverse to the display value zero using distance-to-go.

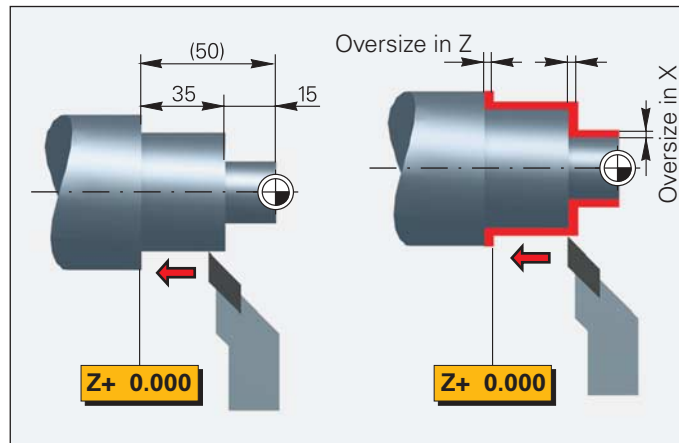
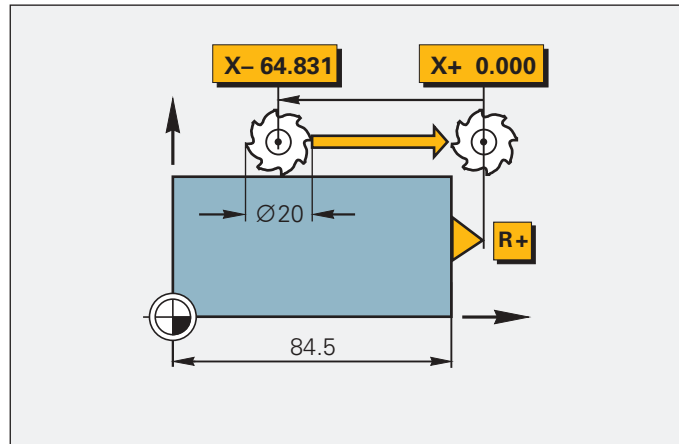

POSITIP:

Contour monitoring for overseeing manual 2-D operations

Particularly for 2-D milling and turning, the contour monitoring function shows you whether you are moving the tool within the tolerances that you set. The magnify function makes this possible even for relatively narrow tolerances while a second window provides you with an overall view of the workpiece.

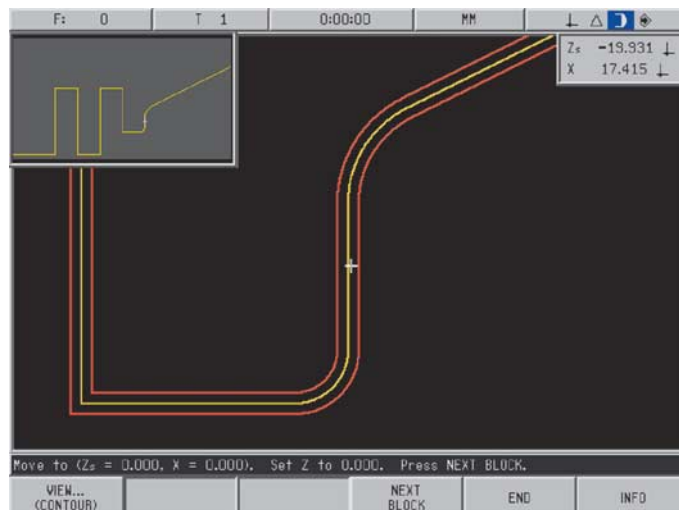

- Hole Patterns and Rectangular Pockets

Automatic calculation of bolt hole patterns for milling and drilling

When the ND 780 and POSITIP readouts are in milling mode, you can produce **bolt hole circles** (full circles and circle segments) and **linear hole patterns** without much manual calculation.

Simply enter the geometric dimensions and the number of holes from the drawing, and the display calculates the coordinates of the individual holes in the working plane. You need only traverse "to zero" and drill—the display then shows you the next position. The **graphic display** is a particularly useful feature: it lets you verify your input of the programmed bolt-hole pattern before machining.

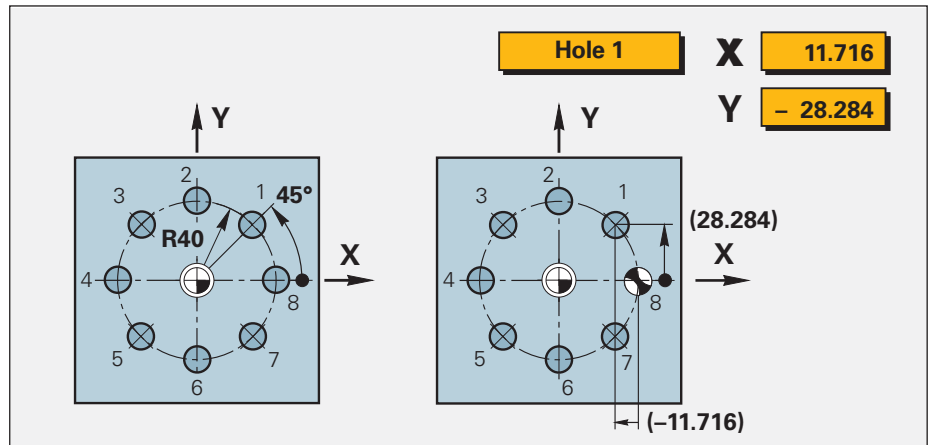
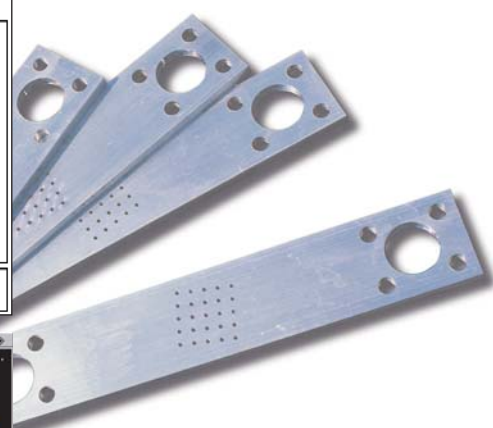
Milling and roughing out rectangular pockets

POSITIP aids you in milling and roughing out rectangular pockets. The display unit calculates from your input the required positioning steps, and you simply traverse to the zero position value.

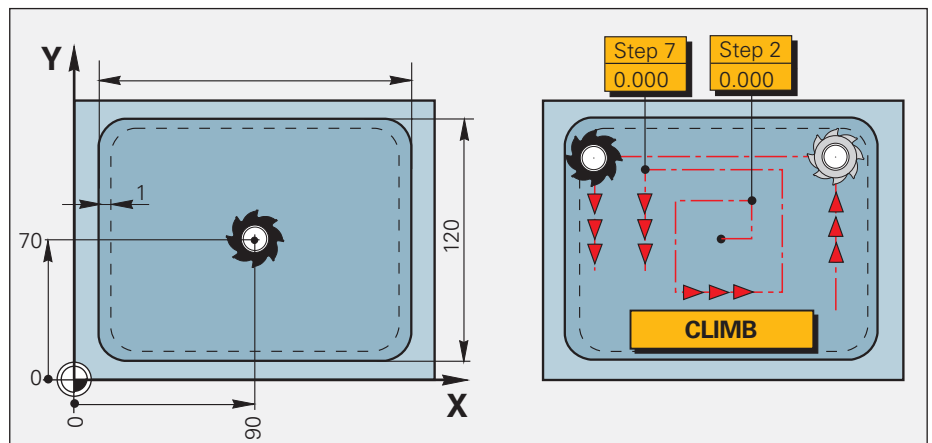

Functions of the ND 780 and POSITIP 880

– Features for Working with Lathes

Radius/diameter display

In lathe mode, the ND 780 and POSITIP 880 show the X-axis positions as either radius or diameter values. You can switch between views with a keystroke.

Sum display of longitudinal axes

In lathe mode, the ND 780 and POSITIP 880 can display the positions of the saddle and the top slide either separately or as the sum of both values.

- If you select **separate displays**, the position values are referenced to the datum for each individual axis. If only the saddle is moved, the displayed value for the top-slide axis remains unchanged.
- If **sum display** is selected, the counter adds both values. You can now read the absolute position of the tool in relation to the workpiece datum – without having to calculate!

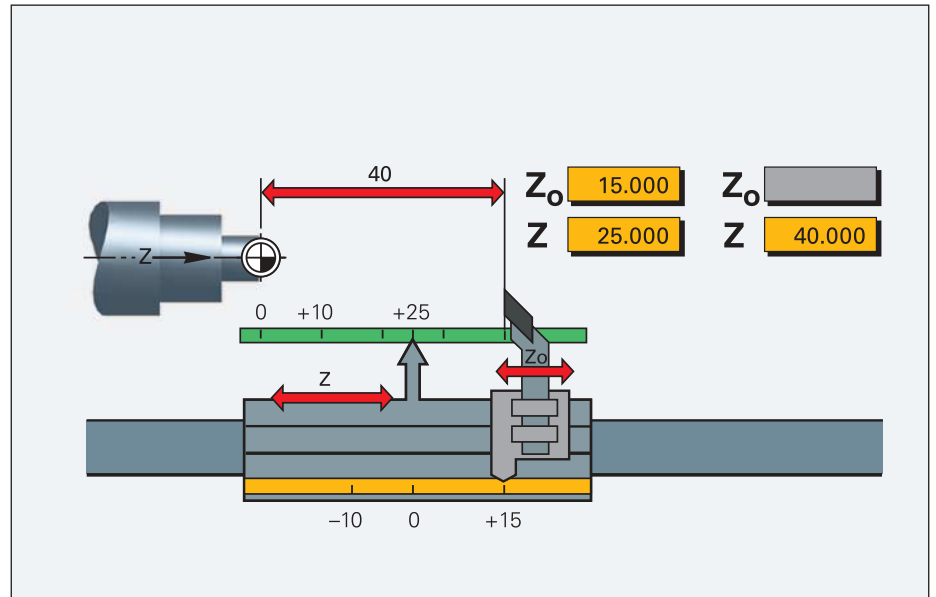

Taper turning made easy

If taper dimensions do not include the angle, POSITIP and the ND 780 will help with the calculations. Simply enter the taper ratio or the two diameters and the length. POSITIP and the ND 780 will immediately display the correct angle for the top slide.

TAPER CALCULATOR

DIAMETER 1 25.000

DIAMETER 2 10.000

LENGTH 50.000

ANGLE 8.531°

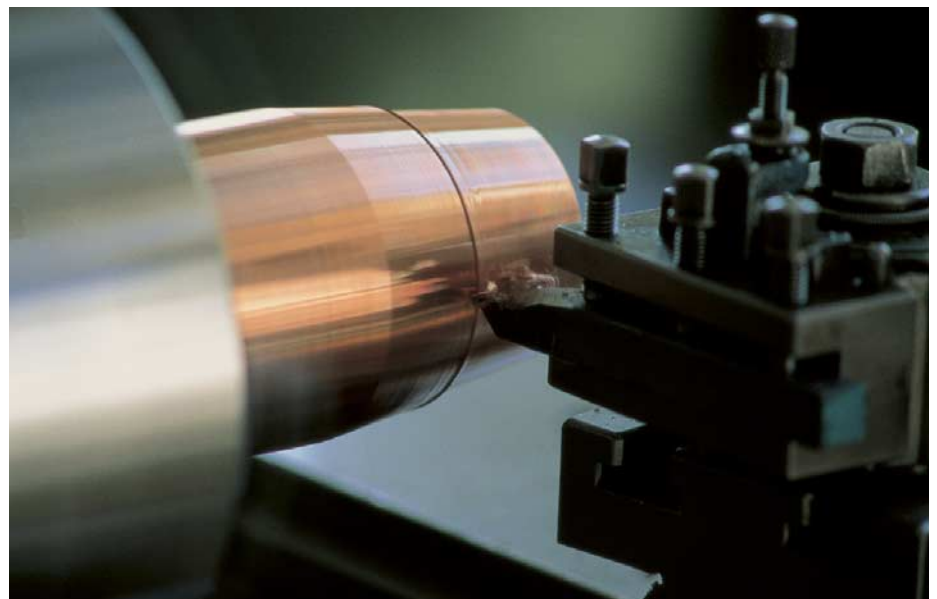

Multipass cycle

The POSITIP readout features a cycle for turning a shoulder in several passes. The distance remaining to the target position is shown both in the longitudinal and tool axes. You decide on the best infeed increment.

Programming Function of the POSITIP

– Small-Batch Production Made Easy

POSITIP's programming functions allow you to save repetitive machining steps. Thus, for example, you can save all of the machining sequences required for a small-batch workpiece as a program. In the programming mode of operation, the distance-to-go display will guide you step-by-step to the programmed positions.

You can combine working steps into a program by either keying the program in step by step or by simply saving the actual positions while machining the first workpiece (teach-in programming).

POSITIP also allows you to generate program-section repeats and subprograms. If you are machining point patterns, you can program incremental positioning steps and then repeat them as often as necessary (program-section repeat). If you need to run the same program sequence at separate locations on the workpiece, you can write a subprogram and call it as needed. This saves you work at the keyboard and reduces inputting errors. Fixed cycles such as Bolt Hole Circle, Linear Hole Pattern or Rectangular Pocket (boring, milling) or Multipass (turning) keep your programs short and save you programming time. In the course of your work, POSITIP presents each nominal position in the proper sequence. You need only move from one position to the next.

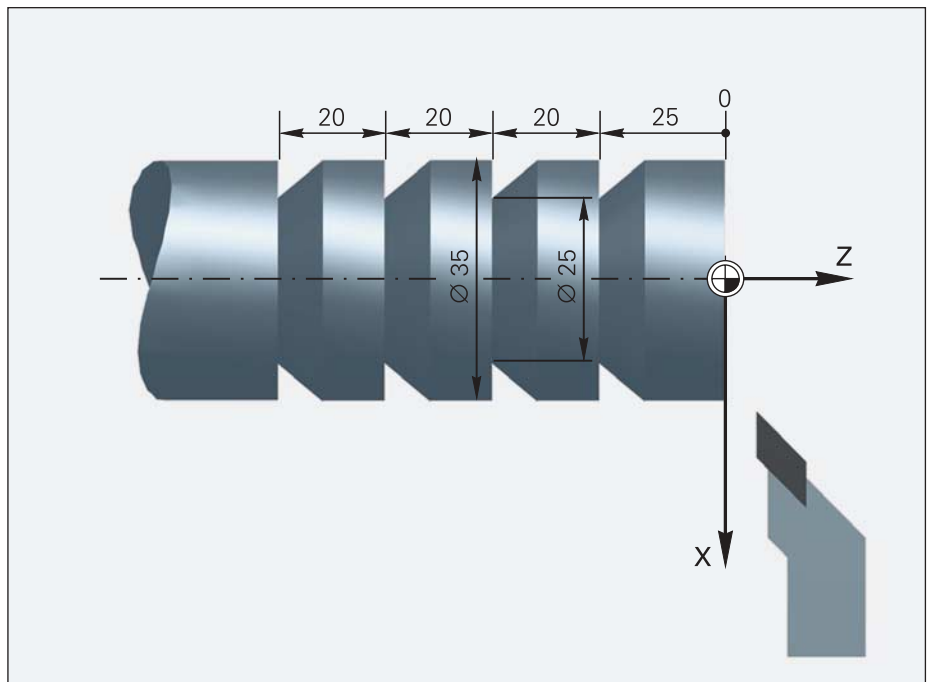
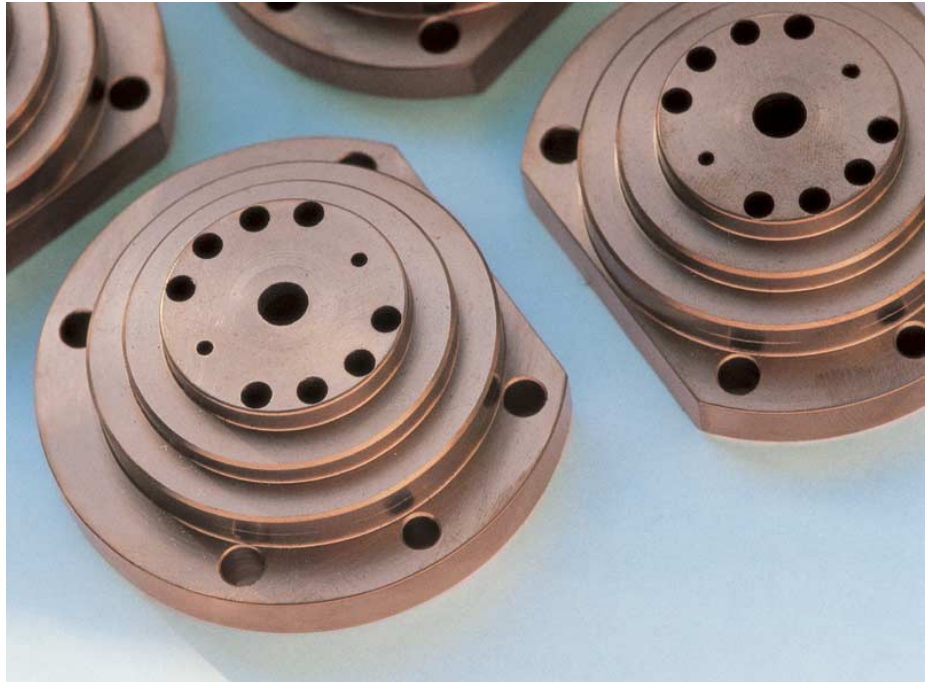

Example of a POSITIP program:
Multiple-recess turning on one
workpiece

```

000 BEGIN PGM 40 MM
001 X+80.000
002 Z+20.000
003 X+40.000
004 Z-5.000
005 LBL #8
006 IZ-20.000
007 X+25.000
008 X+40.000
009 ZYCL 7.0 LBLWDH 8 3/3
010 ZYCL 7.1 AUSZ +0.000
011 ZYCL 7.2 AUSX +0.000
012 X+80.000
013 END PGM 40 MM
  
```

ND 200 Series

– Universal Digital Readouts for One Axis

The ND 200 series readouts are designed for use with one linear encoder, angle encoder, length gauge or rotary encoder. For simple positioning tasks, such as infeed for a circular saw or press travel, as well as for measuring and inspection stations, the ND 221 B is an ideal choice. Numerical position displays make it possible to transfer the measuring results via an RS 232-C interface to a PC or printer. For measuring tasks with special requirements, such as sorting and tolerance checking or minimum/maximum display in a measurement series, HEIDENHAIN recommends the ND 281 B (RS-232-C interface) or the ND 282 B (BCD data output). The switching inputs and outputs of these two models permit operation also in simple automated environments.



ND 281 B

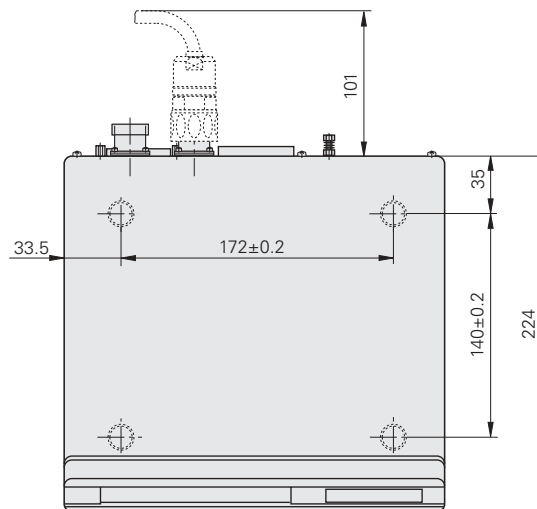
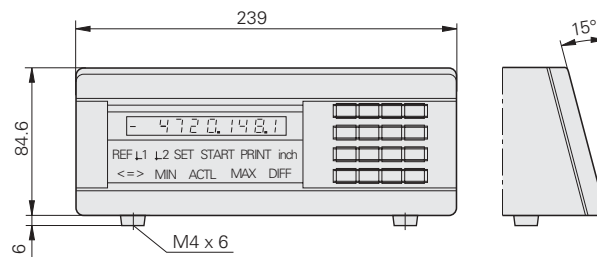

	ND 221 B Length display	ND 281 B Length and angle display	ND 282 B Length display	ND 231 B Sum/difference display
Encoder inputs	1 x \sim 11 μ A _{PP}	1 x \sim 1 V _{PP} or 1 x \sim 11 μ A _{PP} , selectable	1 x \sim 11 μ A _{PP}	2 x \sim 11 μ A _{PP}
Input frequency	Max. 100 kHz	1 V _{PP} : Max. 500 kHz 11 μ A _{PP} : Max. 100 kHz	Max. 50 kHz	Max. 100 kHz
Signal period	From 0.128 μ m to 12 800 μ m			
Line count	–	1800 to 180 000 per 360°	–	
Subdivision factor	Up to 1024-fold		Up to 200-fold	Up to 1024-fold
Display step¹⁾ Length	0.000 001 mm to 0.5 mm			
Angle	–	0.1° to 0.000 002° or 1"	–	
Display	Position values (9 decades plus sign); REF, inch, datum 1/datum 2, SET datum setting			
Status display	Scaling factor (SCL)	PRINT, MIN/MAX/DIFF/ACTL, START, sorting (< = >), scaling factor (SCL)		PRINT, sorting (< = >), scaling factor (SCL)
Features	<ul style="list-style-type: none"> • REF reference mark evaluation for distance-coded or single reference marks • Fast zero reset • 2 reference points 			
	–	<ul style="list-style-type: none"> • Sorting and tolerance check mode • Minimum/maximum value storage 		<ul style="list-style-type: none"> • Sorting and tolerance check mode • Sum/difference display
Axis error compensation	Linear and nonlinear over 64 points			
Data interface	RS-232-C/V.24		BCD	RS-232-C/V.24
Transfer rates	110 to 38 400 baud		0.2 μ s to 25.6 μ s ²⁾	110 to 38 400 baud
Switching outputs for tasks in automation	–	<ul style="list-style-type: none"> • Zero crossover • Switching points 1 and 2 • Sorting signals „<“ and „>“ • Errors 		
Switching inputs for tasks in automation	–	<ul style="list-style-type: none"> • Zero reset, preset • Measured value output, display freeze if necessary (pulse or contact) • Pass over reference point • Inhibit reference pulse X1 		
		<ul style="list-style-type: none"> • External MIN/MAX selection • MIN, MAX or DIFF display • Start measurement series 		<ul style="list-style-type: none"> • X1 or X2 display • Sum display • Difference display • Inhibit reference pulse X2
		–	Deactivate BCD	–
Power supply unit	100 Vac to 240 Vac (–15% to +10%), 50 Hz to 60 Hz (\pm 2 Hz); power consumption: 8 W			
Operating temperature	0 °C to 45 °C (32 °F to 113 °F)			
Protection IEC 60529	IP 40, front panel IP 54			
Weight	1.5 kg (3.3 lb)			

¹⁾ Depends on the signal period or line count of the connected encoder

²⁾ Latch rate with fast concurrent BCD data output

ND 780

– Adaptable Readout for up to Three Axes

The ND 780 digital readout is especially suited for use on milling, drilling and boring machines and lathes with up to three axes.

The ND 780 readout features conversational programming to assist you with positioning tasks and to explain the display's special functions. It is equipped with a monochrome flat screen for position values, dialog and input displays, graphic functions and graphic positioning support.

The **distance-to-go display feature** for positioning tasks allows you to approach the next position quickly and reliably by simply traversing to the display value zero.

The functions for each application are easily activated via parameter entry. Special functions are available for producing **hole patterns** (linear patterns and circular patterns). Reference points can be determined quickly and accurately with a KT 130 edge finder. The ND 780 readout supports you with special **probing functions**.

You can easily switch between radius and diameter display in the Lathe mode. The readout also offers support for lathes with separate top slide: The **sum display feature** allows you to display the saddle and top slides together or separately. To set a reference point, touch the workpiece and **freeze the tool position**. Then retract and measure the workpiece.

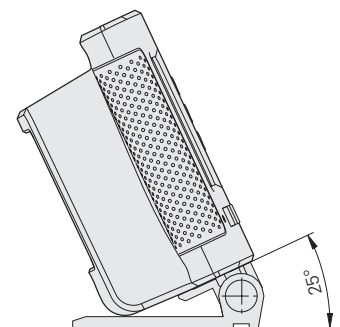
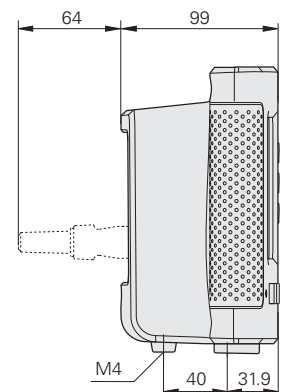
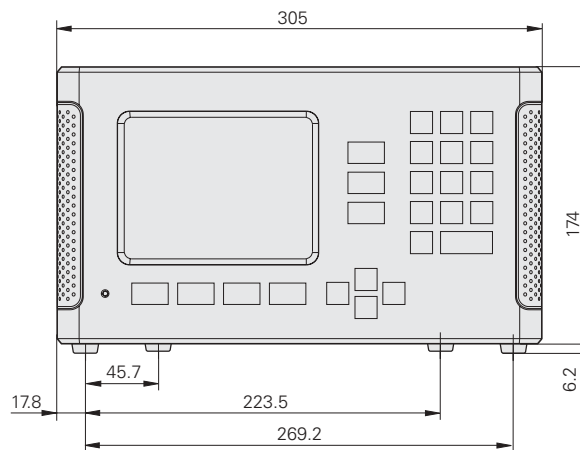

	Milling, drilling and boring machine applications	Lathe applications
Axes	Up to 3 axes from A to Z	Up to 3 axes from A to Z and Z _O , Z _S
Encoder inputs	~ 1 V _{PP} or 3 x ~ 11 μA _{PP} ; 15-pin D-sub connector (automatic detection of interface)	
Input frequency	≤ 100 kHz	
Signal period	2 μm, 4 μm, 10 μm, 20 μm, 40 μm, 100 μm, 10240 μm, 12800 μm	
Line count	Any	
Subdivision factor	Up to 1024-fold	
Display step¹⁾	<i>Linear axis:</i> 1 mm to 0.0001 mm <i>Angular axis:</i> 1° to 0.0001° (00° 00' 01")	
Display	Monochrome flat screen for position values, dialog and input displays, graphic functions and graphic positioning support	
Status display	Operating mode, REF, reference-point number, tool number, inch, scale, feed-rate display, stopwatch	
	Tool compensation R+, R-	Radius/diameter display Separate or sum display for Z and Z _O
Features	<ul style="list-style-type: none"> • 10 reference points • 16 tools • REF reference mark evaluation for distance-coded and single reference marks • Distance-to-go display with nominal position input in absolute or incremental values • Scaling • mm/inch switching • HELP: On-screen operating instructions • INFO: Stopwatch, calculator 	
	<ul style="list-style-type: none"> • Calculation of positions for hole patterns (circular and linear patterns) • Tool-radius compensation • Probing function for reference-point acquisition with the KT edge finder: „Edge,“ „Centerline“ and „Circle center“ • INFO: Cutting-data calculator 	<ul style="list-style-type: none"> • Freezing the tool position value for retraction • Probing functions for reference-point setting with the tool • INFO: Taper calculator
Error compensation	<i>Axis error:</i> Linear and nonlinear over up to 200 points <i>Backlash compensation:</i> For linear measurement via spindle and rotary encoder	
Data interface	RS-232-C/V.24 300 to 115200 baud <ul style="list-style-type: none"> • For output of measured values and parameters • For input of parameters, remote control of keys and commands 	
Switching input	<ul style="list-style-type: none"> • Two inputs (pulse or contact) to measured value output • 1 input for KT edge finder • 1 input for edge finder with contact triggering 	
Accessories	KT edge finder	–
	Tilting base, handle, tilt/swivel mount, pivot arm	
Power supply unit	Primary-clocked power supply 100 Vac to 240 Vac (–15% to +10%), 48 Hz to 52 Hz	
Power consumption	30 W	
Operating temperature	0 °C to 45 °C (32 °F to 113 °F)	
Protection IEC 60529	IP 40, front panel IP 54	
Weight	2.6 kg (5.7 lb)	

¹⁾ Depends on the signal period or line count of the connected encoder

POSITIP 880

– Programmable Readout for up to Six Axes

The POSITIP 880 is a versatile digital readout, designed primarily for milling machines, boring machines and lathes with up to six axes. In addition to the features offered by the ND series of displays, POSITIP offers advanced capabilities. It supports all operations with straightforward interactive menus on its large, easy-to-read color flat screen. And it does it on big machines as well: Since the POSITIP 880 permits the connection of a separate display and control unit, you can have all position values and functions available at a second position.

Diverse functions—ease of operation

Soft keys enable POSITIP to offer a wide range of functions such as zero reset or entry in absolute or incremental dimensions. The functions of all soft keys are identified either with words (in the language of your country) or with easily understood symbols. Each operating mode, work step and screen display has individualized on-screen operating instructions, often with graphic illustrations, which can be called simply by pressing the HELP key. The INFO feature gives you additional on-screen support, such as a pocket calculator, a stopwatch, a cutting data calculator for milling and a taper calculator for settings on the top slide for turning. User parameters are available for setting the radius/diameter switching as well as the separate/sum display of two axes.

Programs for small-batch production

The programming capabilities of POSITIP make it ideal for small-batch production on conventional machine tools: up to 999 program blocks per program can be stored in its memory. Programs can be created either by keying them in step-by-step or generating them through actual position capture (teach-in programming). The subprogramming capability lightens your work load: repetitive machining sequences only have to be entered once. Fixed cycles such as Bolt Hole Circle, Linear Hole Pattern or Rectangular Pocket (boring, milling) or Multipass (turning) keep your programs short and save you programming time.

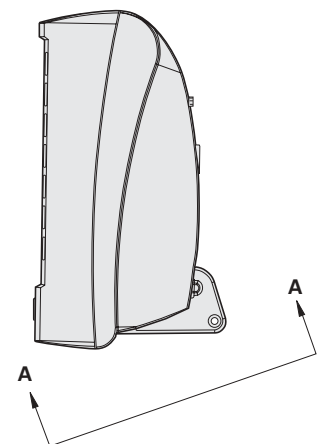
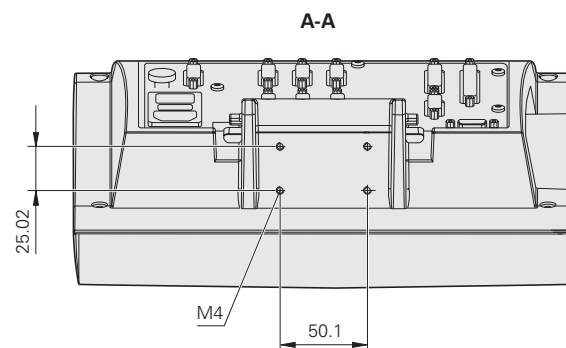
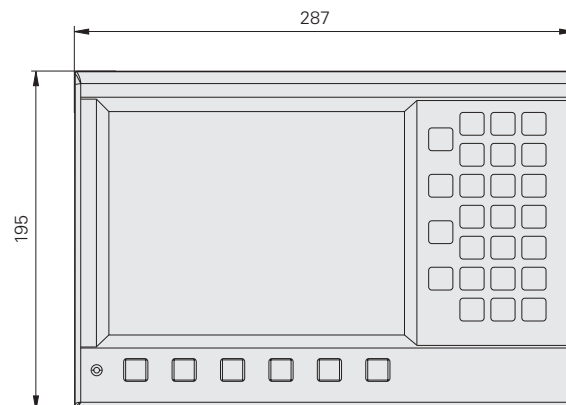

	Milling, drilling and boring machine applications	Lathe applications
Axes	Up to 6 axes from A to Z	Up to 6 axes from A to Z and Z ₀ , Z _s
Encoder inputs	$\sim 1 V_{PP}$, $6 \times \sim 11 \mu A_{PP}$ or EnDat 2.1 (automatic detection of interface)	
Input frequency	≤ 100 kHz	
Signal period	0.128 μm , 2 μm , 4 μm , 10 μm , 20 μm , 40 μm , 100 μm , 10240 μm , 12800 μm	
Line count	Any	
Subdivision factor	Up to 1024-fold	
Display step¹⁾	<i>Linear axis:</i> 1 mm to 0.005 μm <i>Angular axis:</i> 0.01° to 0.0001° (00° 00' 01")	
Display	Color flat screen for position values, dialog and input displays, graphic functions and graphic positioning support	
Status display	Operating mode, REF, distance-to-go, inch, scale, feed-rate display	
	Reference point number Tool number and axis Tool compensation R+, R-, R0	Tool number Radius/diameter display Sum display
Features	<ul style="list-style-type: none"> • REF reference mark evaluation for distance-coded or single reference marks • Distance-to-go display with nominal position input in absolute or incremental values • Scaling • Contour monitoring with zoom function • Any axis combinations • HELP: On-screen operating instructions • INFO: Stopwatch, calculator 	
	<ul style="list-style-type: none"> • 99 reference points, 99 tools • Calculation of positions for hole patterns (circular and linear patterns) • Tool-radius compensation • Probing function for reference-point acquisition with the KT edge finder: „Edge“, „Centerline“ and „Circle center“ • Positioning aids for milling and roughing rectangular pockets • INFO: Cutting-data calculator 	<ul style="list-style-type: none"> • 1 reference point, 99 tools • Freezing the tool position values for retraction • Oversize allowance • INFO: Taper calculator
Programming	999 program blocks per program; subprogramming with rotating and mirroring; Teach-in (actual-position capturing)	
Cycles	Line segments, circular arcs, chamfers, circular and linear hole patterns, rectangular pockets	Line segments, circular arcs, chamfers, multipass
Error compensation	Linear and nonlinear over 128 points	
Data interfaces	Serial	RS-232-C/V.24 300 to 115200 baud <ul style="list-style-type: none"> • For output of programs, measured values and parameters • For loading of programs and parameters
	Parallel	Centronics for output of measured values
Switching inputs/outputs	Via IOB 89 external input/output unit	
Accessories	KT edge finder	–
	Tilting base, tilt/swivel mount, mounting arm, second display unit	
Power supply unit	100 Vac to 240 Vac (-5% to +10%), 50 Hz to 60 Hz (± 2 Hz), power consumption: 35 W	
Operating temperature	0 °C to 45 °C (32 °F to 113 °F)	
Protection IEC 60529	IP 40, front panel IP 54	
Weight	3.2 kg (7.1 lb)	

Mounting

Mounting the ND 200

The readouts of the ND 200 series are easily stackable. Adhesive plug-in feet (supplied with the readout) prevent the stacked units from being moved out of place.

You can secure the readouts from below by using M4 screws.

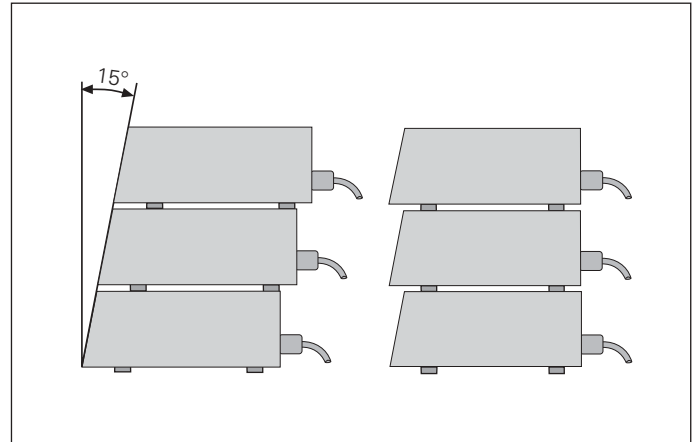

Mounting the ND 780 and POSITIP 880

There are several possibilities for mounting the ND 780 and POSITIP 880 readouts:

- M4 screw on the housing base
- Tilting base
- Mounting frame (for ND 780)
- Tilt/swivel mount
- Mounting arm with tilt/swivel mount

Tilting base (accessory)

For ND 780: Id. Nr. 281619-01

For POSITIP 880: Id. Nr. 382892-01

The tilting base can be used to tilt the readout forward and backward by up to 20°. It can be attached with M5 screws.



Tilting base for ND 780

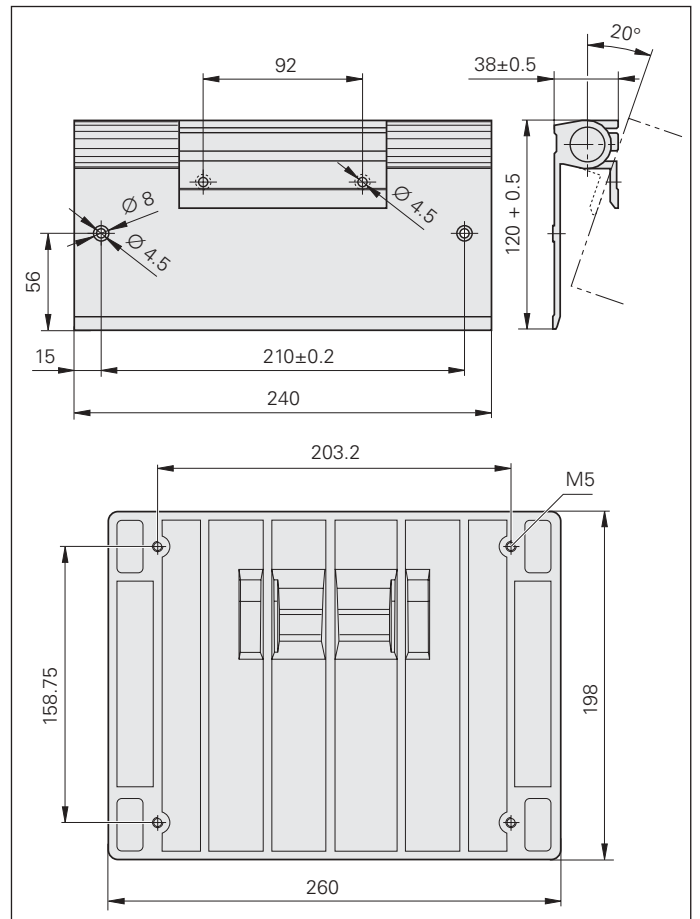

Tilting base for POSITIP 880

Mounting frame (accessory for ND 780)

Id. Nr. 532811-01

For simple mounting of the ND 780 in a housing or operating panel.

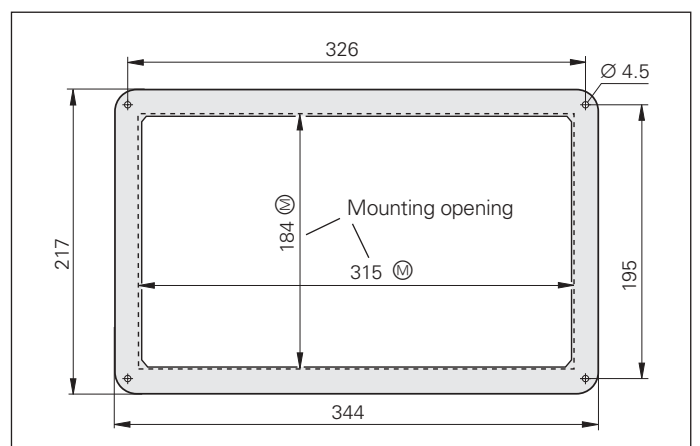

Tilt/swivel mount (accessory)

For ND 780: Id. Nr. 520011-01

For POSITIP: Id. Nr. 382891-01

The mount permits tilting and rotation of the readout. It can be attached to a machine element or mounting arm with M8 screws.

Mounting arm (accessory)

Id. Nr. 382929-01

Use the mounting arm to easily place the display at a conveniently operatable position. It can be attached to the machine and swiveled by either a yoke or a hexagonal head screw. The display is attached to the mounting arm via its own tilt/swivel mount.

Handle (accessory for ND 780)

Id. Nr. 520012-01

The handle is attached to the base of the ND 780, and is used to easily swivel the readout.



Mounting arm

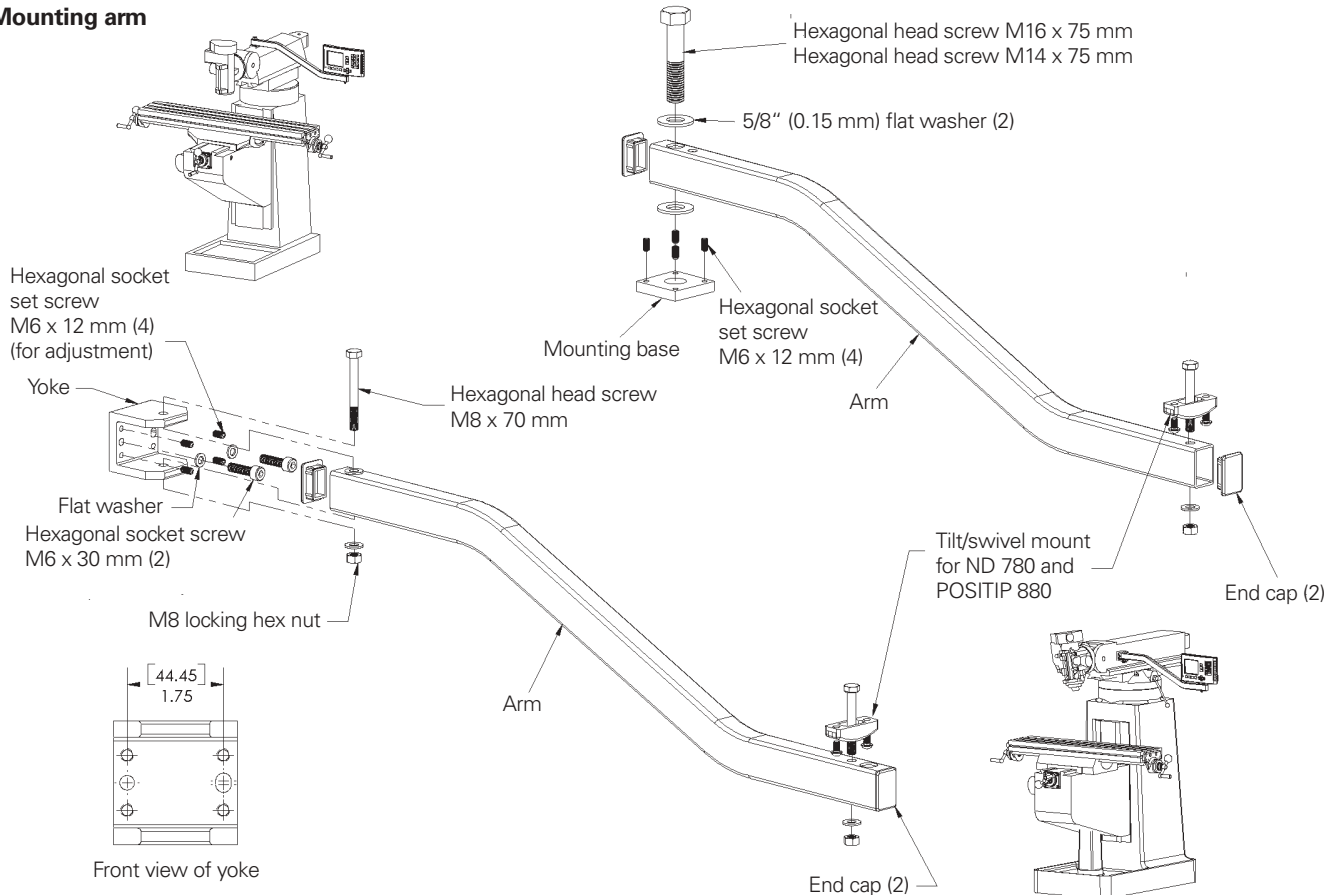

Encoders

Supported encoders

Linear and angle encoders from HEIDENHAIN with various interfaces can be attached to the ND 780, POSITIP and the ND 200 series (see the table).

Setting up the encoder

The versatile readouts from HEIDENHAIN can be adapted to the encoder and the respective operating conditions. The following values can be set via parameters:

- Signal period of the linear encoder
- Line count of the angle or rotary encoder
- Desired display step (resolution)
- Counting direction
- Angle display, etc.

Connection of rotary encoders

Rotary encoders can also be connected to the readouts in order to measure linear distances via lead screw and rotary encoder combinations, or for measuring angles on rotary tables with worm gears. You must take into consideration that the errors of the mechanical transfer elements (spindle-pitch error, reversal error, etc.) directly influence the positioning accuracy. The spindle pitch and line count of the encoder must be chosen such that they result in a signal period available for selection.

Model	Connectable encoders	Interface	Connecting element
ND 281	Incremental linear, angle or rotary encoders	$\sim 1 V_{PP}$	Connector (female) 12-pin M23
		$\sim 11 \mu A_{PP}$	Connector (female) 9-pin M23
ND 221 ND 231 ND 282	Incremental linear encoders	$\sim 11 \mu A_{PP}$	Connector (female) 9-pin M23
ND 780	Incremental linear and angle encoders	$\sim 1 V_{PP}$ $\sim 11 \mu A_{PP}$	D-sub connector 15-pin
POSITIP 880	Incremental linear, angle or rotary encoders	$\sim 1 V_{PP}$ $\sim 11 \mu A_{PP}$	D-sub connector 15-pin
	Absolute linear, angle or rotary encoders	EnDat 2.1	

Signal period for lead screw and rotary encoder combination for linear measurement

Spindle pitch: 10 mm

Line count of the encoder: 1000 lines

Theoretical signal period:

$10 \text{ mm} : 1000 \text{ lines} = 0.01 \text{ mm} = 10 \mu\text{m}$

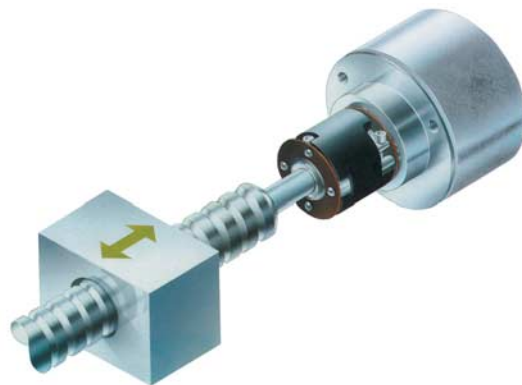

Line count for angular measurement with rotary encoder via a worm gear

Gear ratio 9 : 1

Line count of the encoder:

e.g. 1000 lines

Theoretical line count for angular measurement (any value possible):

$9 \times 1000 \text{ lines} = 9000 \text{ lines}$

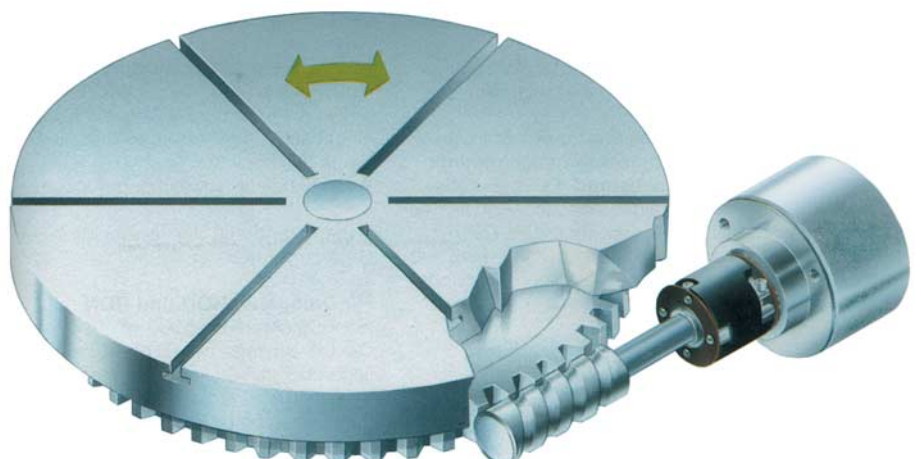

Absolute encoders

With the absolute encoders from HEIDENHAIN, the position value is available from the encoder immediately upon switch-on, and can be called at any time by the readout. There is no need to move the axes to find the reference position. The absolute position information is read directly from the scale graduation, and is output serially as an absolute position value via the bidirectional EnDat interface.

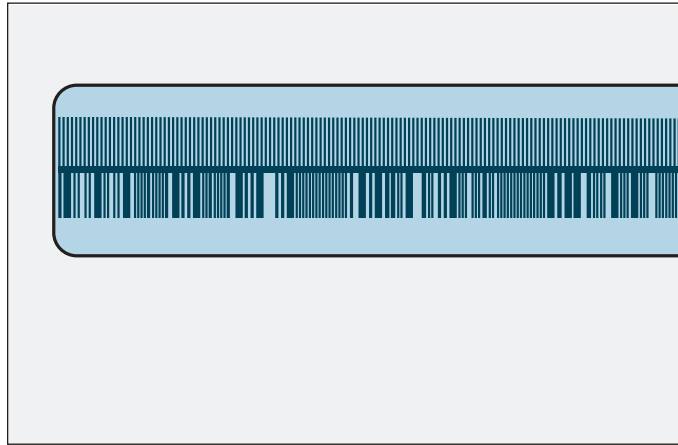

Incremental encoders

Incremental linear and angle encoders from HEIDENHAIN output two sinusoidal signals phase-shifted by 90° as measuring signals, as well as one or more reference-mark signals. The readout often subdivides the sinusoidal measuring signal in order to achieve measuring steps smaller than the signal period.

Incremental measurement means counting while measuring. In order to attain an absolute reference, a **reference mark** is applied to the scale. When the reference mark is traversed, a signal associated with exactly one measuring step is generated. In this manner, the association between the position and the display value specified by the **reference-point setting** is re-established by traversing the reference marks in each axis.

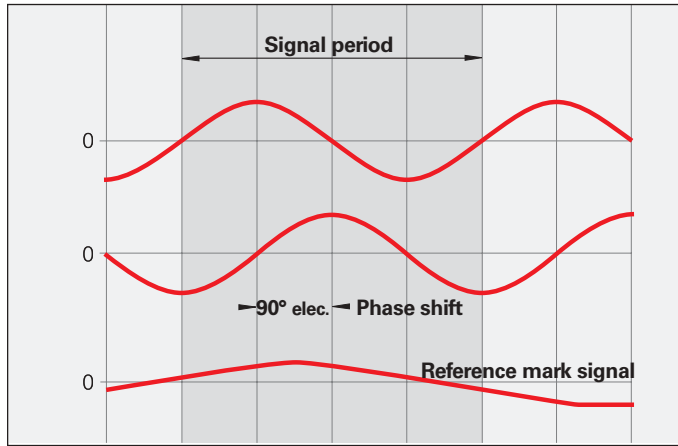

Sinusoidal measuring signals

To speed and simplify the referencing procedure, many HEIDENHAIN scales (and graduated disks of angle encoders) have distance-coded reference marks. On these position encoders, the absolute position is already available after traversing two neighboring reference marks. For example, on linear encoders this distance is at most 20 mm (LS, LF) or 80 mm (LB), and for angle encoders the amount rotated is at most 20°.

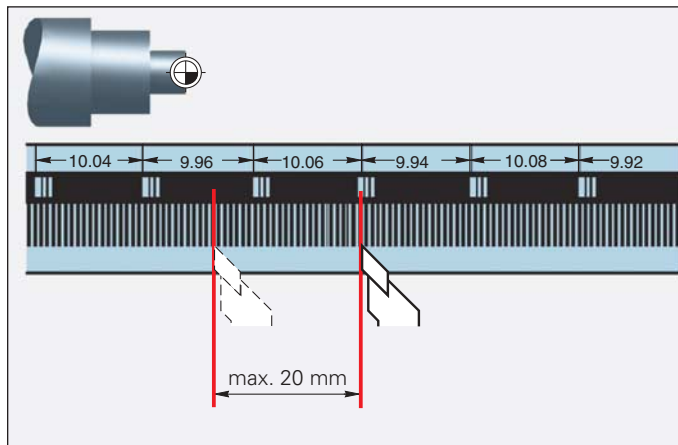

Traverse with distance-coded reference marks

Interfaces

– Encoders

The ND and POSITIP readouts feature universal interfaces for connecting encoders from HEIDENHAIN.

Pin layout for ND 200 series $\sim 11 \mu\text{A}_{\text{pp}}$

Mating connector:
9-pin M23 connector (male)

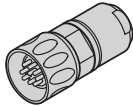
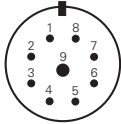





	Power supply				Incremental signals					
	3	4	Housing	9	1	2	5	6	7	8
	U_P	0V	External shield	Inside shield	I_{1+}	I_{1-}	I_{2+}	I_{2-}	I_{0+}	I_{0-}

Shield on housing; U_P = power supply voltage
 Vacant pins or wires must not be used!

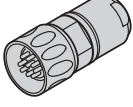
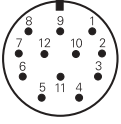
Pin layout for ND 281 $\sim 1V_{\text{pp}}$

Mating connector:
12-pin M23 connector (male)







	Power supply				Incremental signals						Other signals	
	12	2	10	11	5	6	8	1	3	4	9	7
	U_P	Sensor U_P	0V	Sensor 0V	A+	A-	B+	B-	R+	R-	Vacant	Vacant

Shield on housing; U_P = power supply voltage
Sensor: The sensor line is connected in the encoder with the corresponding power line

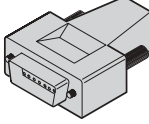
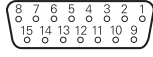
Pin layout for ND 780 and PT 880 $\sim 1V_{\text{pp}}/\sim 11 \mu\text{A}_{\text{pp}}/\text{EnDat 2.1}$

Mating connector:
15-pin D-sub connector (female)





	Power supply					Incremental signals						Absolute position values			
	1	9	2	11	13	3	4	6	7	10	12	5	8	14	15
$\sim 1V_{\text{pp}}$	U_P	Sensor U_P	0V	Sensor 0V	-	A+	A-	B+	B-	R+	R-	-	-	-	-
$\sim 11 \mu\text{A}_{\text{pp}}$					Inside shield	I_{1+}	I_{1-}	I_{2+}	I_{2-}	I_{0+}	I_{0-}	-	-	-	-
EnDat					Inside shield	A+	A-	B+	B-	-	-	DATA	$\overline{\text{DATA}}$	CLOCK	$\overline{\text{CLOCK}}$

Shield on housing; U_P = power supply voltage
Sensor: The sensor line is connected in the encoder with the corresponding power line

– RS-232-C/V.24

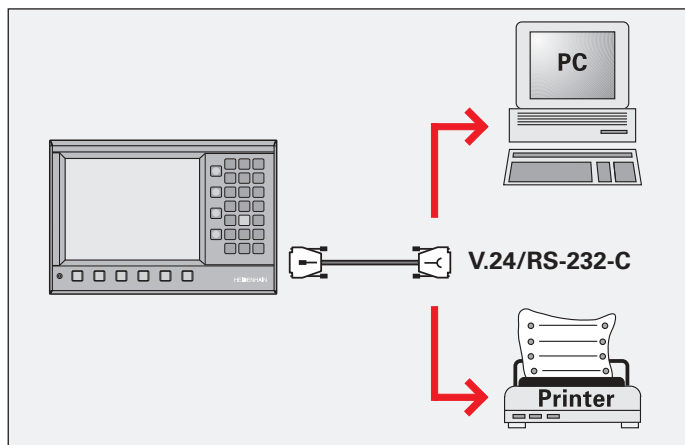
The ND and POSITIP readouts feature **serial data interfaces** as prescribed in the international standards RS-232-C of the EIA and the equivalent V.24 of the CCITT. The interfaces provide serial data output in ASCII code.



Pin	Assignment
1	Do not assign
3	TXD – Transmit Data
2	RXD – Receive Data
7	RTS – Request to Send
8	CTS – Clear to Send
6	DSR – Data Set Ready
5	SIGNAL GND – Signal Ground
4	DTR – Data Terminal Ready
9	Do not assign

Signal	Signal level "1" = Active	Signal level "0" = Not active
TXD, RXD	–3 V to –15 V	+3 V to +15 V
RTS, CTS DSR, DTR	+3 V to +15 V	–3 V to –15 V

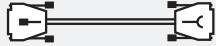
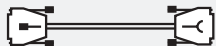
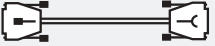
	ND 200	ND 780	POSITIP
Data format	<ul style="list-style-type: none"> Start bit 7 data bits Parity bit (even) 2 stop bits 	Adjustable (default values bold): <ul style="list-style-type: none"> Start bit 7/8 data bits Parity bit (none/even/odd) 1/2 stop bits 	
Data transfer	Output of measured values	<ul style="list-style-type: none"> Output of measured values Read and output programs and parameters 	
Measured value output			
Start	Keyboard	MOD	"Export" soft key
	Interface	CTRL B	CTRL B
	External input	Pulse or contact (at D-sub connection EXT or X10)	
	Edge finder	–	At deflection
Interrupt/continue	DC3/DC1		
Connecting cable	25-pin 25-pin  Id. Nr. 274 545-xx 25-pin 9-pin  Id. Nr. 368 017-xx	9-pin 9-pin 	

Interfaces

– BCD

BCD data interface (ND 282 B)

All data in BCD code is transmitted as parallel output.

After a latch command, the ND stores the current measured value in its internal buffer. This latch command is released either

- at the ND by pressing the MOD key until the PRINT indicator blinks (only for "slow" data output),
- **externally** through a latch command at the **D-sub** or the **BCD connection** (pulse or contact), or
- **internally** through a periodic clock (**concurrent data output**). The clock time is adjustable from 0.2 to 25.6 μs .

A data strobe at the BCD output indicates to the connected electronics that the measured value is stable (ready message).

There are two selectable **data output speeds**:

- **slow** — the display value is output after 8 to 21.5 ms (depending on the selected mode of operation), and
- **fast** — the measured value referenced to datum 1 will be output after 0.6 μs ; MIN/MAX/DIFF values cannot be output.

Signal level

Output (TTL):

$$U_L \leq 0.4 \text{ V at } I_L \leq 6 \text{ mA}$$

$$U_H \geq 3.8 \text{ V at } I_H \leq 2.6 \text{ mA}$$

Latch signal (pulse or contact)

$$U_H \geq 3.8 \text{ V at } I_{\text{max}} \leq 6 \text{ mA}$$

$$U_L \leq 0.9 \text{ V at } I_{\text{max}} \leq 6 \text{ mA}$$

or TTL level (internal pull-up resistor: 10 $\text{k}\Omega$)

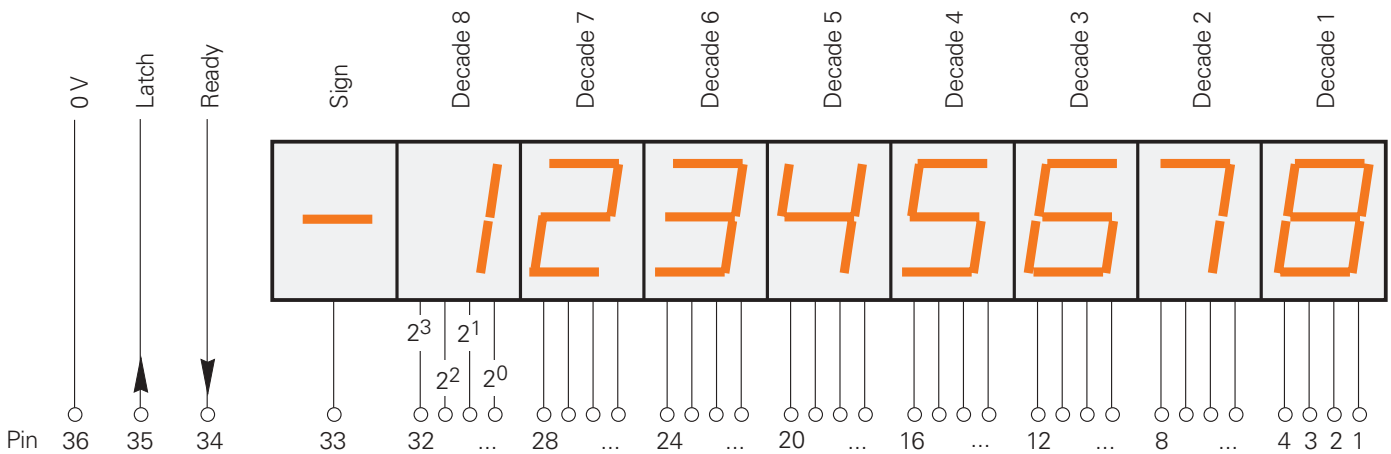

Connection of several NDs with BCD data interface to one subsequent unit

The BCD output of the ND 282 B display unit has a three-state function. Through its separate D-sub input, all data lines of an ND can be switched to high impedance in order to deactivate its BCD output. This makes it possible to specify exactly which **one** display unit will transmit the measured values to the subsequent electronics.

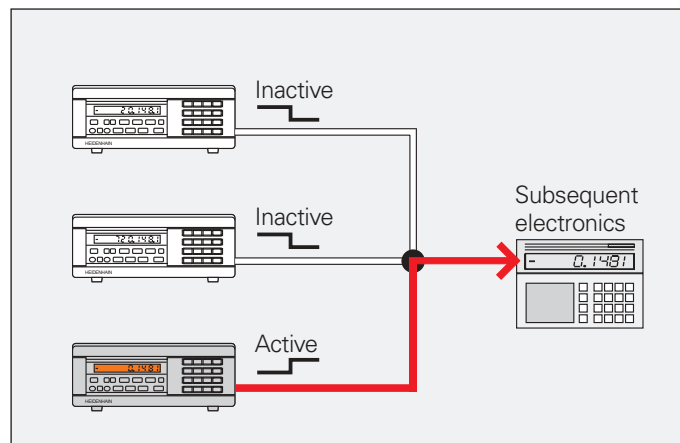

– Switching Inputs

All switching inputs respond either to contact or pulse.

Exception: The switching inputs for transmitting measured values over the data interface are separate for contact and pulse (see “Interfaces”).

The switching input E is active when a Low signal U_L is applied (contact or pulse to 0 V).

Signal level

$-0.5\text{ V} \leq U_L \leq 0.9\text{ V}$ at $I_L \leq 6\text{ mA}$
 $3.9\text{ V} \leq U_H \leq 15.0\text{ V}$

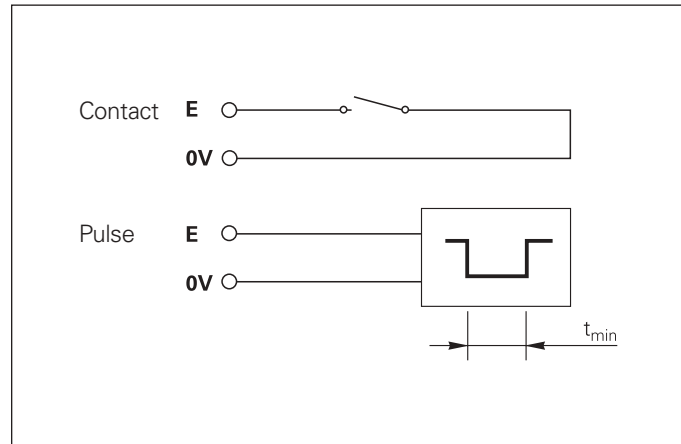

ND 2xx:
 $t_{min} \geq 55\text{ ms}$

ND 780/IOB 89:
 $t_{min} \geq 100\text{ ms}$

Functions of the switching inputs

To find the functions available with the various display units, see the tables beginning on page 16.

Zero reset/preset

Each axis can be set by an external signal to the display value zero or, with the ND 200 series, to a value stored in a parameter (SET).

Activating or deactivating REF mode

(ND 200 series)

After switch-on or a power interruption, the display unit can be switched externally to REF mode. The next signal then deactivates REF mode (switchover function).

Ignoring the reference mark signal

(reference pulse inhibitor; ND 200 series)

When the input is active, the display unit ignores all reference mark signals. This feature is typically used for linear measurement via rotary encoder and leadscrew; at a certain position, a cam switch reactivates reference signal reception.

External MIN/MAX selection Switching the MIN/MAX/DIFF/ACTL display

The Minimum/Maximum display feature in a series of measurements can be activated externally for the ND 200 series (the Low signal must remain on at the switching input).

The keyboard of the ND is nonfunctional during this time. The MIN/MAX/DIFF/ACTL display and the START of a new measurement series are controlled externally via additional switching inputs.

Additional inputs for the ND 231 B

The ND 231 B has two encoder inputs. Having two switching inputs makes it possible to control which encoder is used for position display; two further switching inputs control the display of the sum or difference from the two encoders.

– Switching Outputs of the ND 200 Series

Certain measured value display units of the **ND 200 series** feature freely definable trigger points that can be used through the switching outputs for tasks in automation.

Switching outputs of the ND 200 series

The ND 200 series displays have open-collector outputs that switch to 0 V (active = Low).

Delay of signal output:

$t_V \leq 22 \text{ ms}$; when additional features are active (such as for measurements in a series) the delay time may increase.

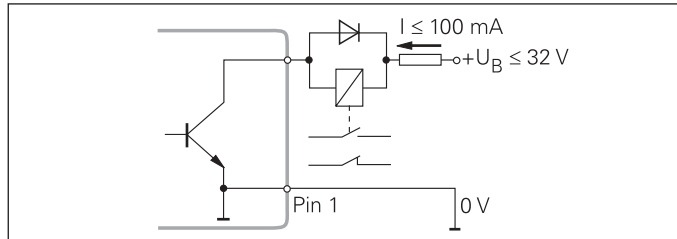

Signal level

$$U_L \leq 0.4 \text{ V at } I_L \leq 100 \text{ mA}$$

$$U_H \leq 32 \text{ V at } I_H \leq 10 \mu\text{A}$$

Trigger points (ND 200 series)

When the measured value reaches trigger points defined by parameter, the corresponding output becomes active. Up to two trigger points can be defined. There is a separate output for the "zero" trigger point (see "Zero crossover").

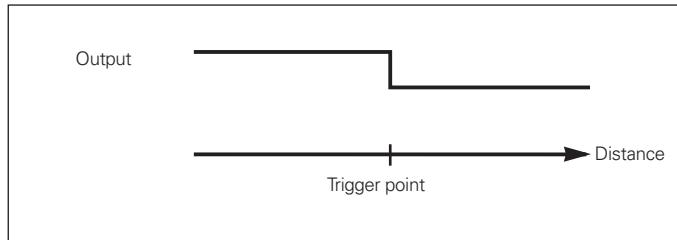

Sorting limits

When the measured value exceeds the limits defined via parameters, the corresponding outputs become active.

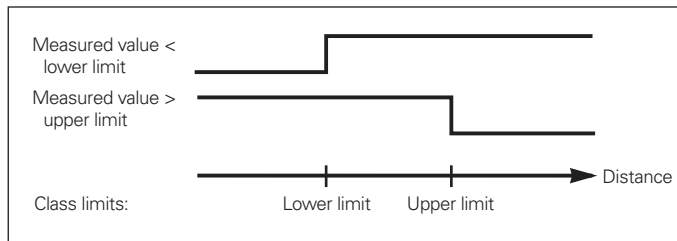

Switching signal for errors

The ND 200 series displays constantly monitor the measuring signals, the input frequency, the data output, etc. for errors, and report errors as they occur with error messages. If an error occurs that may distort the measurement or corrupt the data, the display activates a switching output. This makes it possible to monitor proper function during automated processes.

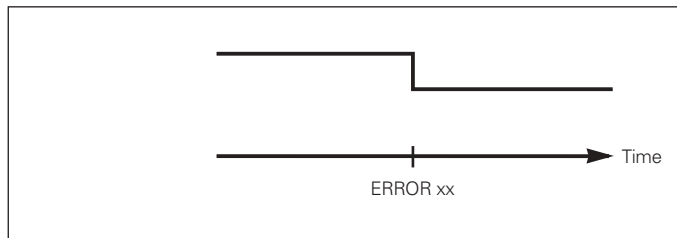

Zero crossover

At the display value „zero,” the corresponding output becomes active. The minimum signal duration is 180 ms.

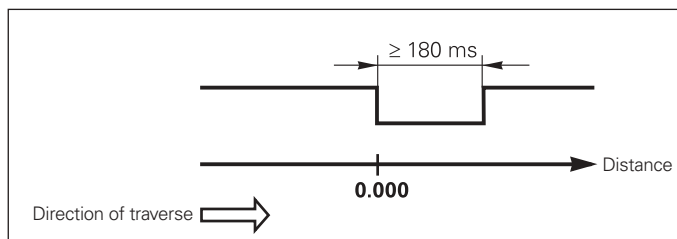

Switching Outputs of the POSITIP 880

– IOB 89 External Input/Output Unit

The POSITIP 880 features switching functions which you can define as you wish. The IOB 89 external input/output unit is necessary to output the switching signals.

Id. Nr. 532884-01

The IOB 89 input/output unit is attached to a standard NS 35 rail (DIN 46227 or EN 50022). It is connected to the POSITIP 880 via the AMI (auxiliary machining interface). LEDs show the status of the inputs and outputs.

Accessories:

Connecting cable complete with connector, between IOB 89 and POSITIP 880

Id. Nr. 532856-xx

Signal level of the switching outputs

$U_L \leq 1.5 \text{ V}$ at $I_L \leq 100 \text{ mA}$

$U_H \leq 24 \text{ V}$ at $I_H \leq 0.3 \text{ mA}$

Delay of signal output

$t_V \leq 10 \text{ ms}$

The switching outputs can be configured on the POSITIP 880 when the IOB 89 is connected, and assigned to any axes. The following functions are possible:

Output of the traverse direction

The output switches with each change of the direction of traverse.

Switch-off ranges

The switch-off ranges are located symmetrically around the display value 0. They can be assigned to the axes in any manner. In the distance-to-go display mode (traverse to 0), switch-off signals are generated for any target position.

Trigger points

The output switches at the programmed position. The algebraic sign is taken into account. (See the diagram for *Trigger points* of the *ND 200 series*)

Readiness

This permanently available output is at LOW level when the POSITIP 880 cannot operate the IOB (e.g. not switched on, cable interrupted, etc.).

IOB 89	
8 switching inputs	<ul style="list-style-type: none"> • Zero axes 1 to 6 • Start data output (contact or pulse)
9 switching outputs	8 freely definable switching outputs 1 switching output ready for POSITIP 880
Power supply	Device: 24 Vdc \pm 20 %/max. 1 A Inputs: 5 V or 24 Vdc \pm 20 %/min. 0.25 A
Cable lengths	Max. 10 m to the POSITIP 880
Storage temperature	-20 to 70 °C (-4 °F to 158 °F)
Operating temperature	0 to 45 °C (32 °F to 113 °F)

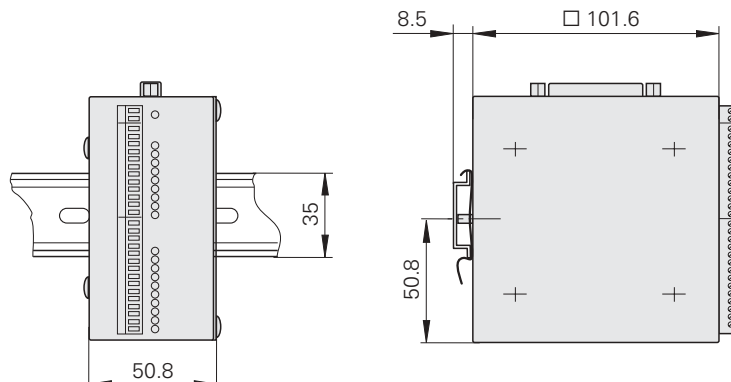
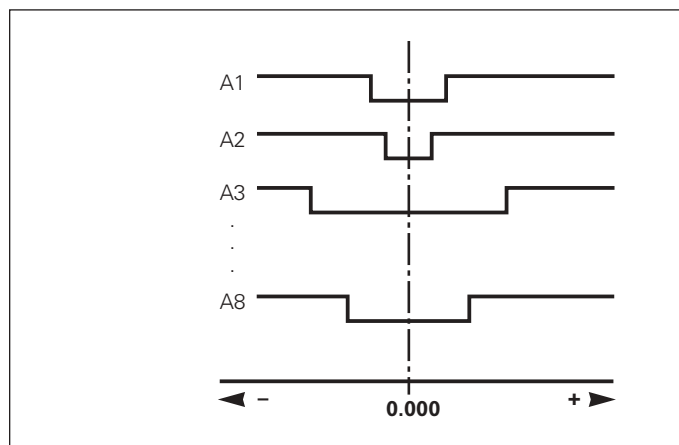
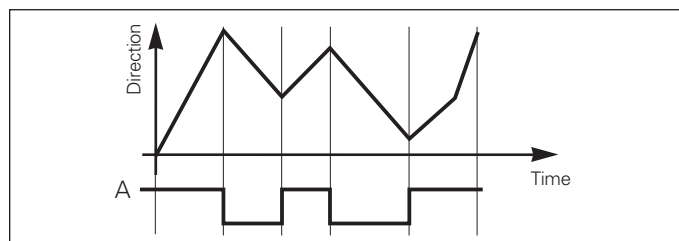
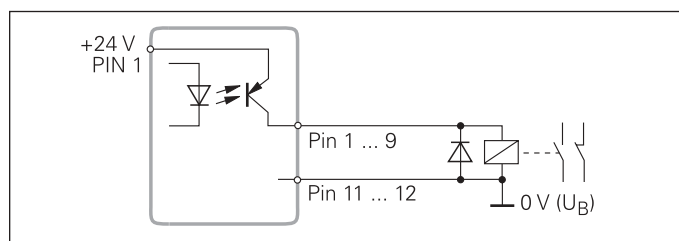

Linear Encoders

– for Manually Operated Machine Tools

For typical applications on manual machine tools such as milling machines or lathes, **display steps of 10 µm or 5 µm** are sufficient. Such display steps are provided by the LS 388 C and LS 603 linear encoders with an accuracy grade of better than $\pm 10 \mu\text{m}$ per meter traverse.

Jig boring machines, grinding machines, and measuring and inspection tasks normally require **display steps of 1 µm** and better. Linear encoders for these more stringent requirements typically feature accuracy grades of $\pm 5 \mu\text{m}$ per meter traverse.

These linear encoders, such as LS 487 or LS 186, are described in the *Linear Encoders for NC-Controlled Machine Tools* brochure.

For **limited installation space**, for example on the slide of a lathe, the linear encoders may be the best solution.

The linear encoders with full-sized scale housing function as universal linear encoders under **normal mounting conditions**.

Linear encoders for large traverses

On large boring or milling machines, but also on lathes with long Z axes, traverse ranges can extend three meters and more. HEIDENHAIN has the proper linear encoders for such special applications.

The **LB 382** with full-sized scale housing makes **measuring lengths of up to 30 040 mm** possible. The housing is assembled from sections and mounted on the machine, and the single steel scale tape is then pulled into its slot. The LB 382 is listed in the *Linear Encoders for NC-Controlled Machine Tools* brochure.

The **LIM 581** magnetic linear encoder is intended for reduced accuracy requirements. For **measuring lengths up to 28 040 mm**, the housing is assembled on the machine from sections and a single scale tape is inserted.

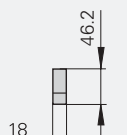
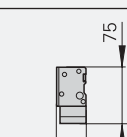
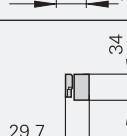
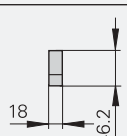
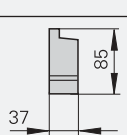
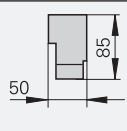
Recommended measuring step	Model	Accuracy grade	Measuring lengths	Dimensions	For more information
10 µm, 5 µm	LS 388 C $\sim 1 V_{PP}$ Slimline linear encoder for limited installation space	$\pm 10 \mu\text{m}$	Up to 1240 mm		Page 33
	LS 603 C $\sim 11 \mu A_{PP}$ Universal linear encoder	$\pm 10 \mu\text{m}$	Up to 3040 mm		
10 µm	LIM 581 $\sim 1 V_{PP}$ Linear encoder for traverse path up to 28 m	$\pm 100 \mu\text{m}$	Up to 28 040 mm		LIM 500 Product Information
1 µm, 0.5 µm	LS 487 C $\sim 1 V_{PP}$ Slimline linear encoder for limited installation space	$\pm 5 \mu\text{m}$ $\pm 3 \mu\text{m}$	Up to 1240 mm <i>Only with mounting spar:</i> Up to 2040 mm		<i>Linear Encoders for NC-Controlled Machine Tools</i> brochure
	LS 186 C $\sim 1 V_{PP}$ Universal linear encoder	$\pm 5 \mu\text{m}$ $\pm 3 \mu\text{m}$	Up to 3040 mm		
10 µm, 5 µm, 1 µm	LB 382 C $\sim 1 V_{PP}$ Linear encoder for traverse path up to 30 m	$\pm 5 \mu\text{m}$	Up to 30 040 mm		



Specifications	Incremental	
	LS 388 C	LS 603
Scale housing	Slimline	Full size
Measuring standard	Glass scale with DIADUR graduation	
Accuracy grade	± 10 µm	
Measuring length ML*	70 120 170 220 270 320 370 420 570 620 670 720 770 820 870 920 970 1020 1140 1240	170 220 270 320 370 420 470 570 620 720 770 820 920 1020 1140 1240 1340 1440 1540 1640 1740 1840 2040 2240 2440 2640 2840 3040
Incremental signals	~ 1 V _{pp}	~ 11 µA _{pp}
Grating period	20 µm	
Reference mark	Distance-coded	LS 603: Selectable with magnets every 50 mm Default setting: 1 reference mark at midpoint of measuring length LS 603 C: Distance-coded
Recommended display step ¹⁾	10 µm, 5 µm	
Power supply	5 V ± 5 % / < 100 mA (without load)	
Electrical connection	Separate adapter cable (1 m/3 m/5 m/9 m) connectible to mounting block	
Cable lengths	≤ 30 m (with HEIDENHAIN cable)	
Traversing speed	≤ 60 m/min	
Required moving force	≤ 5 N	≤ 10 N
Vibration 55 to 2000 Hz Shock 6 ms	≤ 150 m/s ² (IEC 60 068-2-6) ≤ 300 m/s ² (IEC 60 068-2-27)	≤ 30 m/s (IEC 60 068-2-6) ≤ 200 m/s ² (IEC 60 068-2-27)
Operating temperature	0 to 50 °C (32 °F to 122 °F)	
Protection IEC 60 529	IP 53 when installed according to mounting instructions IP 64 with use of compressed air	
Weight	0.27 kg + 0.67 kg/m ML	0.7 kg + 2 kg/m ML

* Please indicate when ordering

¹⁾ For position capture

Dimensions

LS 388 C

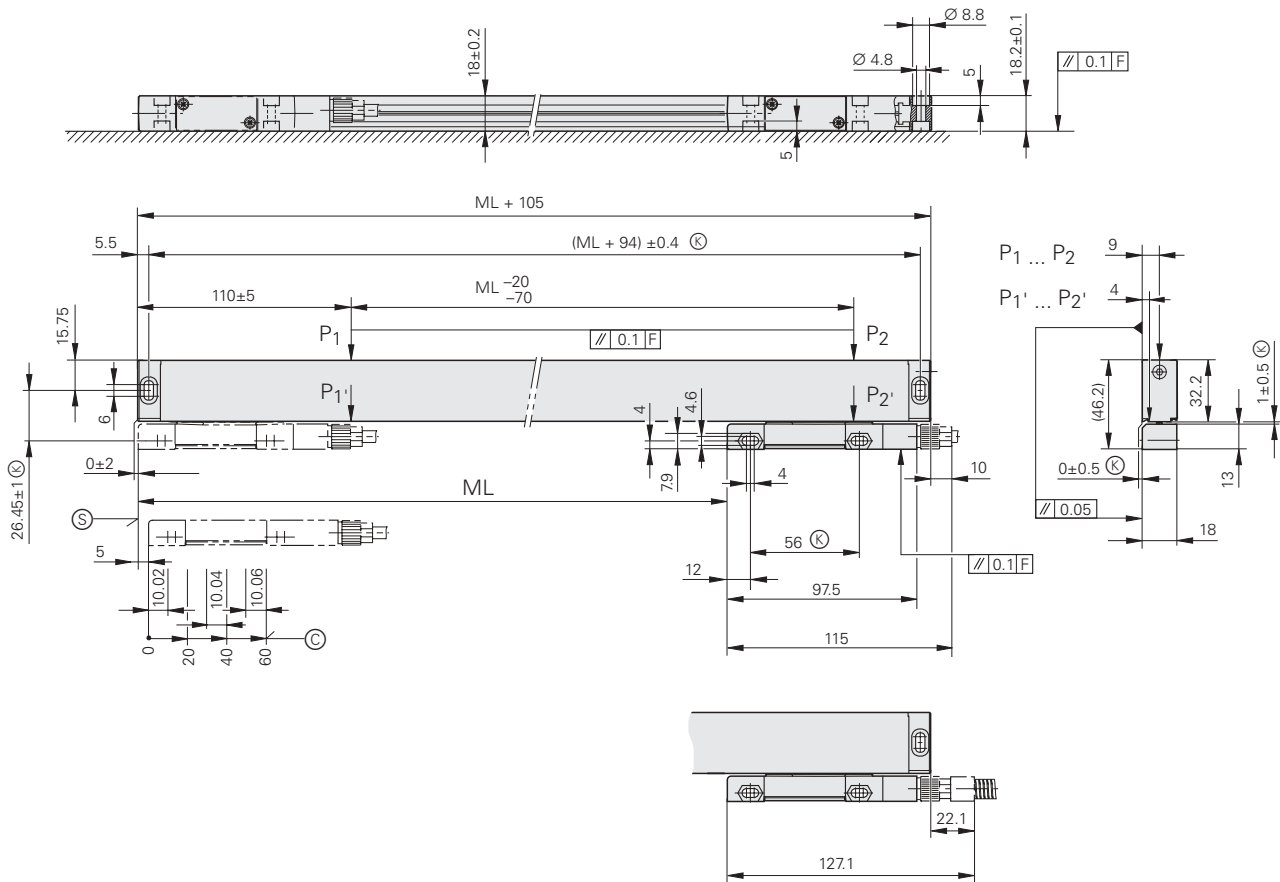

Dimensions in mm



Tolerancing ISO 8015

ISO 2768 - m H

< 6 mm: ± 0.2 mm

Ⓜ = Beginning of measuring length (ML)

Ⓞ = Reference mark position

F = Machine guideway

P = Gauging points for alignment

Ⓚ = Required mating dimensions

LS 603

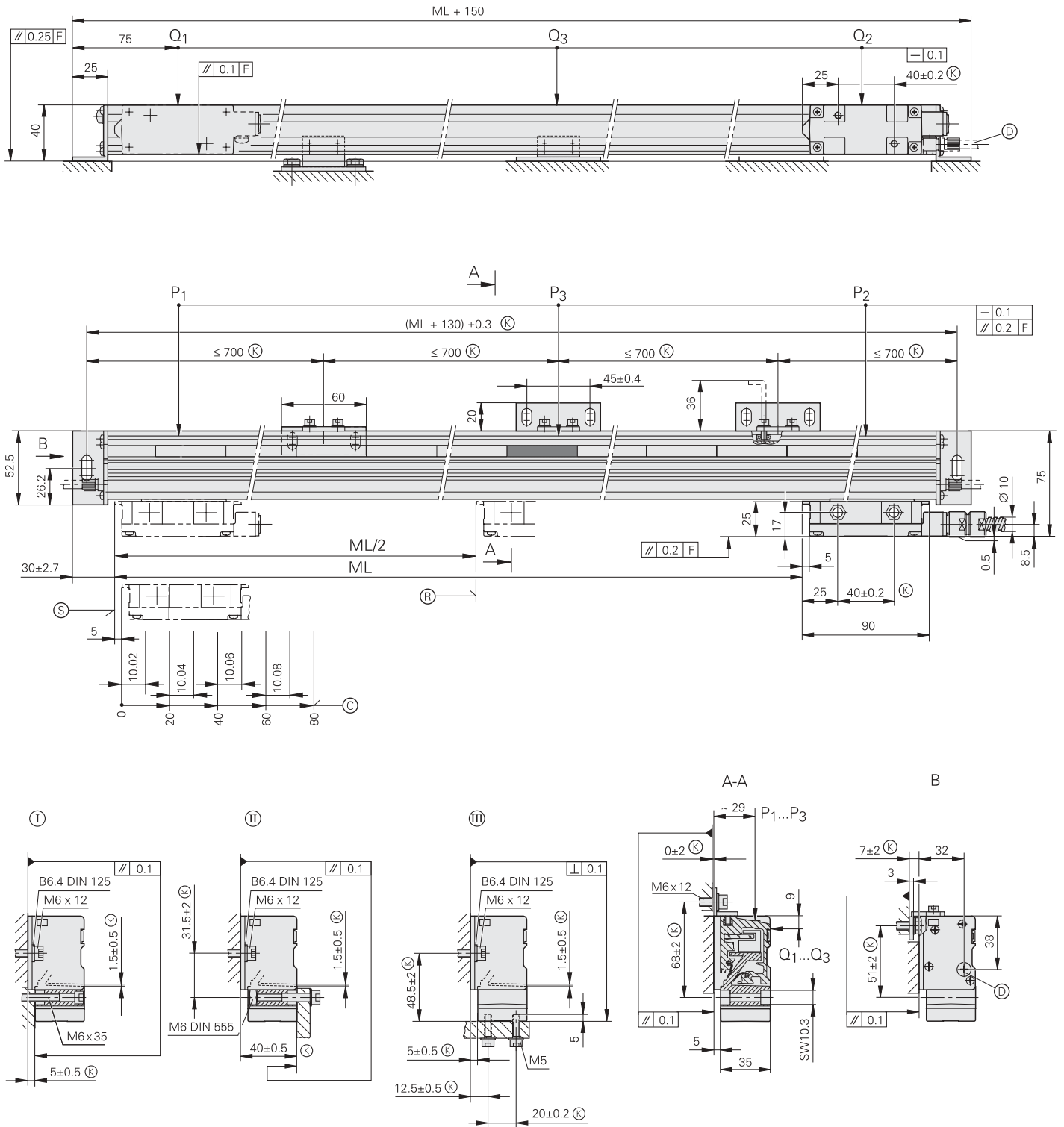

Dimensions in mm



Tolerancing ISO 8015
ISO 2768 - m H
< 6 mm: ± 0.2 mm

- $\textcircled{I}, \textcircled{II}$
- \textcircled{III} = Mounting options
- F = Machine guideway
- P, Q = Gauging points for alignment
- \textcircled{K} = Required mating dimensions
- \textcircled{D} = Compressed air inlet
- \textcircled{H} = Reference mark position on LS 603
- \textcircled{C} = Reference mark position on LS 603 C
- \textcircled{S} = Beginning of measuring length (ML)

Mounting Guidelines

LS 388C

The LS 388C slimline linear encoder should be fastened to a machined surface.

The encoder is mounted so that the sealing lips are directed downward or away from splashwater.

Mounting

It is surprisingly simple to mount the LS 388C: You need only align the scale unit at several points along the machine guideway. Stop surfaces or stop pins can also be used to align the scale.

Use the mounting gauge to easily and quickly set the gap between the scale housing and the scanning unit. Ensure that the lateral tolerances are also maintained.

Accessories

Mounting gauge

Id. Nr. 528 753-01

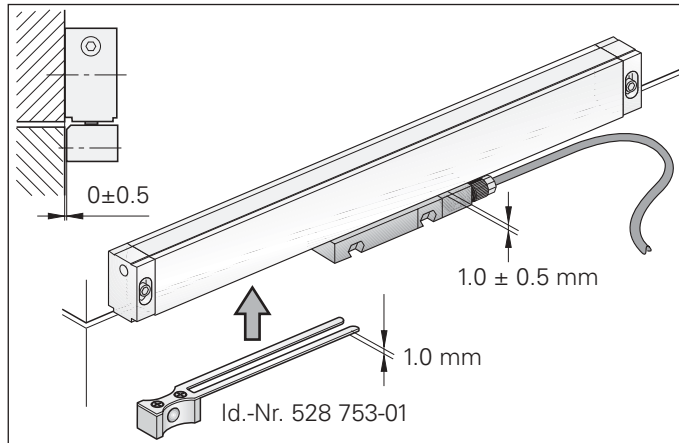
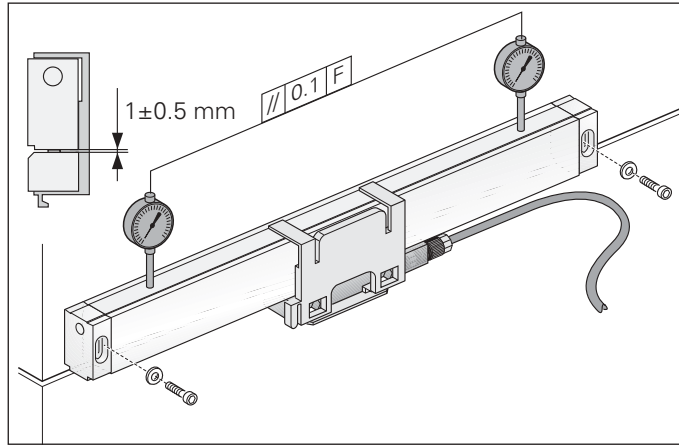

LS 603

The LS 603 full-size linear encoder is fastened to a machined surface only at its ends with its mounting blocks. Measuring lengths over 620 mm (24.4 in) require support brackets to improve vibration behavior.

The inclined arrangement of the sealing lips permits universal mounting with vertical or horizontal scale housing with equally high protection rating.





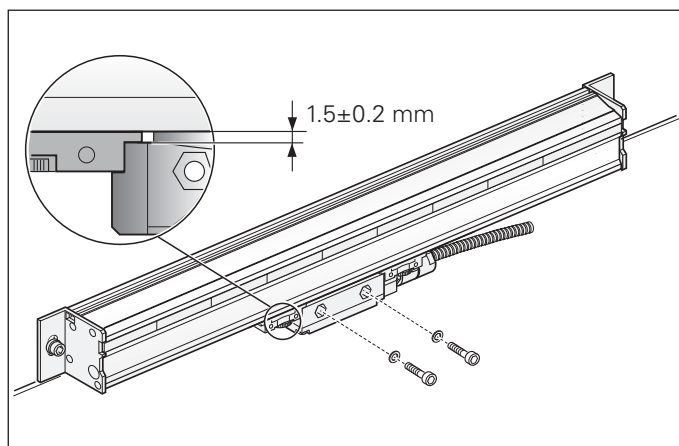
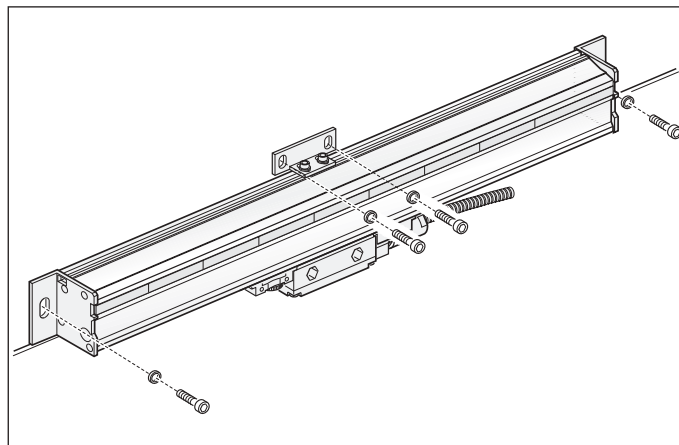

Mounting

When mounting the LS 603, the shipping brace already sets the proper gap between the scale unit and the scanning unit. You need only align the scale unit at several points along the machine guideway.

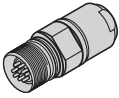
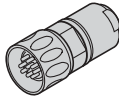
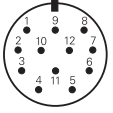
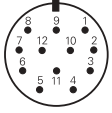

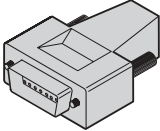
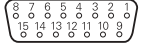
Electrical Connection







Pin layout for LS 388C

12-pin M23 coupling		12-pin M23 connector				15-pin D-sub connector							
													
	Power supply				Incremental signals						Other signals		
	12	2	10	11	5	6	8	1	3	4	9	7	/
	1	9	2	11	3	4	6	7	10	12	5/8/ 13/15	14	-
	U_P	Sensor U _P	0V	Sensor 0V	A+	A-	B+	B-	R+	R-	Vacant	Vacant	Vacant
	Brown/ Green	Blue	White/ Green	White	Brown	Green	Gray	Pink	Red	Black	/	Violet	Yellow

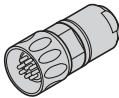
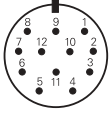
Shield on housing; **U_P** = power supply voltage

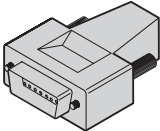
Sensor: The sensor line is connected internally with the corresponding power line.



Pin layout for LS 603

9-pin M23 connector					15-pin D-sub connector								
													
	Power supply				Incremental signals								
	3	4	Housing	9	1	2	5	6	7	8			
	1	2	/	13	3	4	6	7	10	12			
	U_P	0V	External shield	Inside shield	I₁ +	I₁ -	I₂ +	I₂ -	I₀ +	I₀ -			
	Brown	White	/	White/ Brown	Green	Yellow	Blue	Red	Gray	Pink			

Shield on housing; **U_P** = power supply voltage



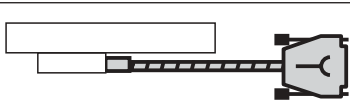

Vacant pins or wires must not be used!

Connecting Elements and Cables

Adapter cable		LS 388C	LS 603
Adapter cable with M23 connector (male) Cable diameter: 6 mm for ND 200 or for extension		344 228-xx	310 573-xx
Armored adapter cable with M23 connector (male) Cable diameter: 10 mm for ND 200 or for extension		344 451-xx	310 731-xx ¹⁾
Adapter cable with D-sub connector (15-pin) Cable diameter: 6 mm for ND 780 and PT 880		360 974-xx	579 563-xx
Armored adapter cable with D-sub connector (15-pin) Cable diameter: 10 mm for ND 780 and PT 880		539 878-xx	368 605-xx ¹⁾

Available cable lengths: 1 m/3 m/6 m/9 m

¹⁾ Available cable lengths: 1 m/3 m/6 m

PUR connecting cable Ø 8 mm 12-pin: [4(2 x 0.14 mm ²) + (4 x 0.5 mm ²)] 9-pin: [3(2 x 0.14 mm ²) + (2 x 1.0 mm ²)]		LS 388C 12-pin	LS 603 9-pin
Complete with M23 coupling (female) and M23 connector (male)		298 400-xx	309 774-xx
Armored cable, complete with M23 coupling (female) and M23 connector (male)		–	309 775-xx
Complete with M23 coupling (female) and D-sub connector (female)		309 783-xx	368 172-xx
With one connector with M23 coupling (female)		298 402-xx	309 780-xx
Cable only		244 957-01	244 955-01

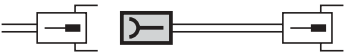
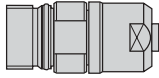
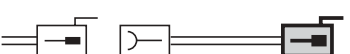
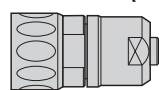
Connecting element		LS 388C 12-pin	LS 603 9-pin
Mating element on connecting cable to connector on encoder cable For connecting cable, diameter 8 mm		M23 coupling (female) 	291 698-02 291 698-01
Connector on cable for connection to subsequent electronics For connecting cable, diameter 8 mm		M23 connector (male) 	291 697-08 291 697-04

HEIDENHAIN

DR. JOHANNES HEIDENHAIN GmbH

Dr.-Johannes-Heidenhain-Straße 5
83301 Traunreut, Germany
☎ +49 (8669) 31-0
FAXI +49 (8669) 5061
E-Mail: info@heidenhain.de

www.heidenhain.de

DE HEIDENHAIN Technisches Büro Nord

12681 Berlin, Deutschland
☎ (030) 54705-240
E-Mail: tbn@heidenhain.de

HEIDENHAIN Technisches Büro Mitte

08468 Heinsdorfergrund, Deutschland
☎ (03765) 69544
E-Mail: tbn@heidenhain.de

HEIDENHAIN Technisches Büro West

58093 Hagen, Deutschland
☎ (02331) 9579-0
E-Mail: tbw@heidenhain.de

HEIDENHAIN Technisches Büro Südwest

70771 Leinfelden-Echterdingen, Deutschland
☎ (0711) 993395-0
E-Mail: tbsw@heidenhain.de

HEIDENHAIN Technisches Büro Südost

83301 Traunreut, Deutschland
☎ (08669) 31-1345
E-Mail: tbs@heidenhain.de

AR NAKASE SRL.

B1653AOX Villa Ballester, Argentina
☎ +54 (11) 47684242
E-Mail: nakase@nakase.com

AT HEIDENHAIN Techn. Büro Österreich

83301 Traunreut, Germany
☎ +49 (8669) 31-1337
E-Mail: tba@heidenhain.de

AU FCR Motion Technology Pty. Ltd

Laverton North 3026, Australia
☎ +61 (3) 93626800
E-Mail: vicsales@fcrmotion.com

BE HEIDENHAIN NV/SA

1760 Roosdaal, Belgium
☎ +32 (54) 343158
E-Mail: sales@heidenhain.be

BG ESD Bulgaria Ltd.

Sofia 1172, Bulgaria
☎ +359 (2) 9632949
E-Mail: info@esd.bg

BR DIADUR Indústria e Comércio Ltda.

04763-070 – São Paulo – SP, Brazil
☎ +55 (11) 5696-6777
E-Mail: diadur@diadur.com.br

BY Belarus → RU

CA HEIDENHAIN CORPORATION

Mississauga, Ontario L5T2N2, Canada
☎ +1 (905) 670-8900
E-Mail: info@heidenhain.com

CH HEIDENHAIN (SCHWEIZ) AG

8603 Schwerzenbach, Switzerland
☎ +41 (44) 8062727
E-Mail: verkauf@heidenhain.ch

CN HEIDENHAIN (TIANJIN) OPTICS & ELECTRONICS CO., LTD

Beijing 101312, China
☎ +86 10-80420000
E-Mail: sales@heidenhain.com.cn

CS Serbia and Montenegro → BG

CZ HEIDENHAIN s.r.o.

106 00 Praha 10, Czech Republic
☎ +420 272658131
E-Mail: heidenhain@heidenhain.cz

DK TP TEKNIK A/S

2670 Greve, Denmark
☎ +45 (70) 100966
E-Mail: tp-gruppen@tp-gruppen.dk

ES FARRESA ELECTRONICA S.A.

08028 Barcelona, Spain
☎ +34 934092491
E-Mail: farresa@farresa.es

FI HEIDENHAIN Scandinavia AB

02770 Espoo, Finland
☎ +358 (9) 8676476
E-Mail: info@heidenhain.fi

FR HEIDENHAIN FRANCE sarl

92316 Sèvres, France
☎ +33 01 41 143000
E-Mail: info@heidenhain.fr

GB HEIDENHAIN (G.B.) Limited

Burgess Hill RH15 9RD, United Kingdom
☎ +44 (1444) 247711
E-Mail: sales@heidenhain.co.uk

GR MB Milionis Vassilis

17341 Athens, Greece
☎ +30 (210) 9336607
E-Mail: bmilioni@otenet.gr

HK HEIDENHAIN LTD

Kowloon, Hong Kong
☎ +852 27591920
E-Mail: service@heidenhain.com.hk

HR Croatia → SL

HU HEIDENHAIN Kereskedelmi Képviselet

1239 Budapest, Hungary
☎ +36 (1) 4210952
E-Mail: info@heidenhain.hu

ID PT Servitama Era Toolsindo

Jakarta 13930, Indonesia
☎ +62 (21) 46834111
E-Mail: ptset@group.gts.co.id

IL NEUMO VARGUS MARKETING LTD.

Tel Aviv 61570, Israel
☎ +972 (3) 5373275
E-Mail: neumo@neumo-vargus.co.il

IN ASHOK & LAL

Chennai – 600 030, India
☎ +91 (44) 26151289
E-Mail: ashoklal@satyam.net.in

IT HEIDENHAIN ITALIANA S.r.l.

20128 Milano, Italy
☎ +39 02270751
E-Mail: info@heidenhain.it

JP HEIDENHAIN K.K.

Tokyo 102-0073, Japan
☎ +81 (3) 3234-7781
E-Mail: sales@heidenhain.co.jp

KR HEIDENHAIN LTD.

Suwon, South Korea, 443-810
☎ +82 (31) 2011511
E-Mail: info@heidenhain.co.kr

MK Macedonia → BG

MX HEIDENHAIN CORPORATION MEXICO

20235 Aguascalientes, Ags., Mexico
☎ +52 (449) 9130870
E-Mail: info@heidenhain.com

MY ISOSERVE Sdn. Bhd

56100 Kuala Lumpur, Malaysia
☎ +60 (3) 91320685
E-Mail: isoserve@po.jaring.my

NL HEIDENHAIN NEDERLAND B.V.

6716 BM Ede, Netherlands
☎ +31 (318) 581800
E-Mail: verkoop@heidenhain.nl

NO HEIDENHAIN Scandinavia AB

7300 Orkanger, Norway
☎ +47 72480048
E-Mail: info@heidenhain.no

PH Machinebanks Corporation

Quezon City, Philippines 1113
☎ +63 (2) 7113751
E-Mail: info@machinebanks.com

PL APS

02-473 Warszawa, Poland
☎ +48 228639737
E-Mail: aps@apserwis.com.pl

PT FARRESA ELECTRÓNICA, LDA.

4470 - 177 Maia, Portugal
☎ +351 229478140
E-Mail: fep@farresa.pt

RO Romania → HU

RU Gertner Service GmbH

113035 Moskau, Russian Federation
☎ +7 (495) 931-9645
E-Mail: heidenhain@gertnergrou.de

SE HEIDENHAIN Scandinavia AB

12739 Skärholmen, Sweden
☎ +46 (8) 53193350
E-Mail: sales@heidenhain.se

SG HEIDENHAIN PACIFIC PTE LTD.

Singapore 408593,
☎ +65 6749-3238
E-Mail: info@heidenhain.com.sg

SK Slovakia → CZ

SL Posredništvo HEIDENHAIN SAŠO HÜBL s.p.

2000 Maribor, Slovenia
☎ +386 (2) 4297216
E-Mail: hubl@siol.net

TH HEIDENHAIN (THAILAND) LTD

Bangkok 10250, Thailand
☎ +66 (2) 398-4147-8
E-Mail: info@heidenhain.co.th

TR T&M Mühendislik Mümessilik

34728 Erenköy-Istanbul, Turkey
☎ +90 (216) 3022345
E-Mail: info@tmmuhendislik.com

TW HEIDENHAIN Co., Ltd.

Taichung 407, Taiwan
☎ +886 (4) 23588977
E-Mail: info@heidenhain.com.tw

UA Ukraine → RU

US HEIDENHAIN CORPORATION

Schaumburg, IL 60173-5337, USA
☎ +1 (847) 490-1191
E-Mail: info@heidenhain.com

VE Maquinaria Diekmann S.A.

Caracas, 1040-A, Venezuela
☎ +58 (212) 6325410
E-Mail: purchase@diekmann.com.ve

VN AMS Advanced Manufacturing Solutions Pte Ltd

HCM City, Viêt Nam
☎ +84 (8) 9123658 - 8352490
E-Mail: davidgoh@amsvn.com

ZA MAFEMA SALES SERVICES C.C.

Midrand 1685, South Africa
☎ +27 (11) 3144416
E-Mail: mailbox@mafema.co.za

