

MP250 touch probe system for grinding machines

www.renishaw.com/mp250

The world's first strain gauge inspection probe for grinding machines, using Renishaw's patented **RENGAGE™** technology.

System components

MP250 probe

An ultra compact touch probe for grinding machines that sets new standards for the precision measurement of 3D part geometries, whilst offering all the standard probing benefits of reduced set-up times, reduced scrap and improved process control.

HSI interface

Hardwired transmission interface which conveys and processes signals between the inspection probe and the CNC machine control.

FS1 and FS2 probe holders

Provide a robust mounting position for the probe and a fully screened hardwired connection between the probe and the interface.

PSU3 power supply

Used when a 12 V to 30 V power supply is not available on the CNC machine.

System features

High accuracy

Patented **RENGAGE™** strain gauge technology with ultra-low pre-travel variation provides high accuracy, even when the application requires long styli. This allows sub-micron 3D performance on a range of applications which demand high precision measurement such as contoured surfaces, for example gear teeth and cutting tools. Probe calibration times are reduced compared to standard probes.

Highly repeatable

Improved repeatability in all probing directions compared to standard probes.



Ultra compact

Measuring only $\varnothing 25$ mm x 40 mm long, the MP250 is ideal for grinding machine applications with restricted space.

Robust and reliable

Renishaw's MP250 sets new standards for reliability and is designed to resist harsh machine conditions.

The MP250 probe is sealed for use within the grinding machine's hostile environment, where it is subject to particle laden coolant. The diaphragm material is resistant to coolants and elevated temperatures.

The MP250 offers resistance to shock and false triggering through the use of digital filtering.

Solid-state strain gauge technology reduces the effects of mechanical wear resulting in greatly increased life compared to other probes.

MP250 dimensions

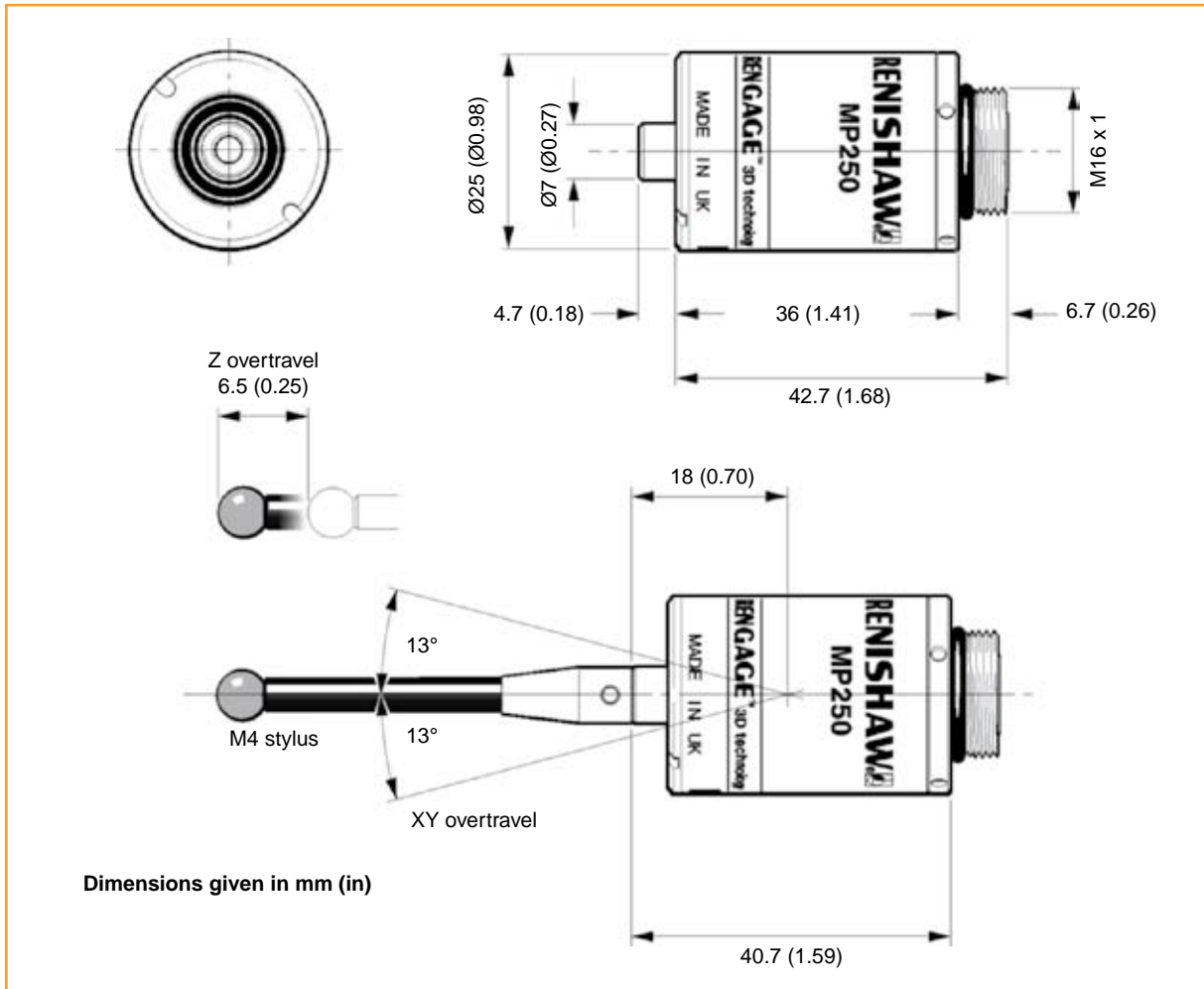

HSI dimensions

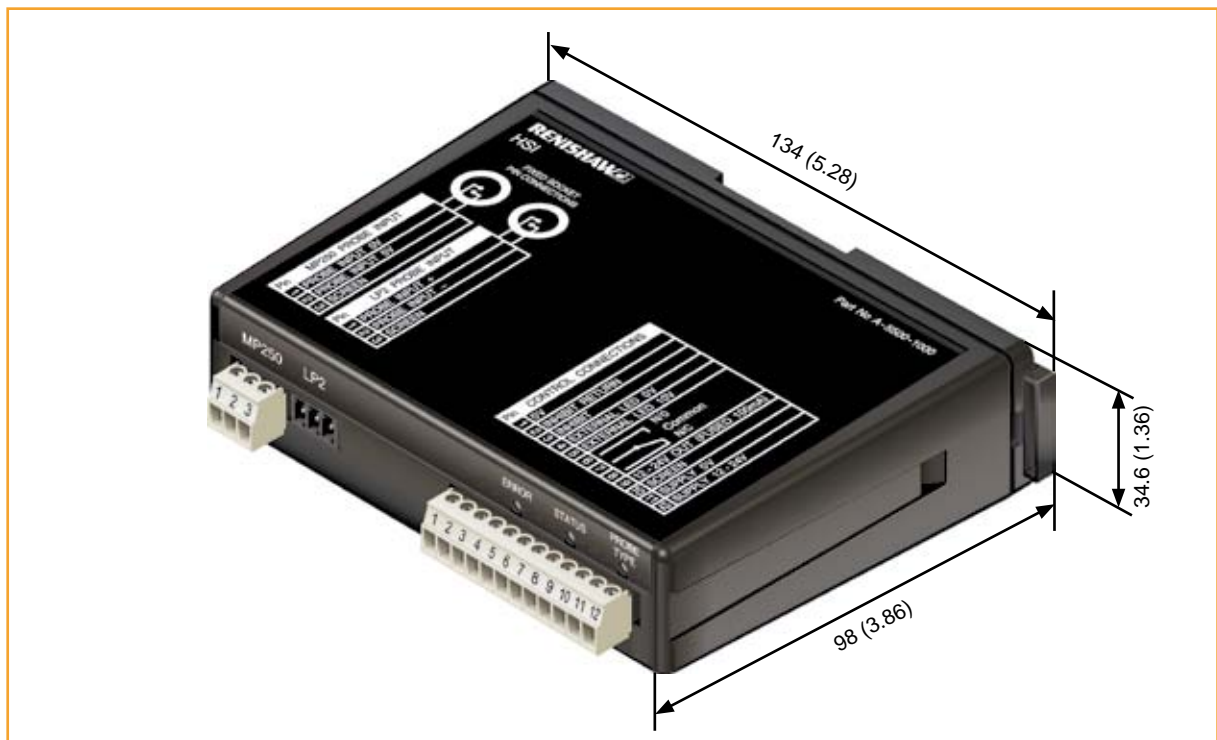

Probe holder dimensions

Dimensions given in mm (in)

Wire colour	Pin connection
Blue	Inner spring pin
Green	Outer spring pin

Cover for FS1 and FS2 to protect against ingress of chips or coolant when the probe is removed.

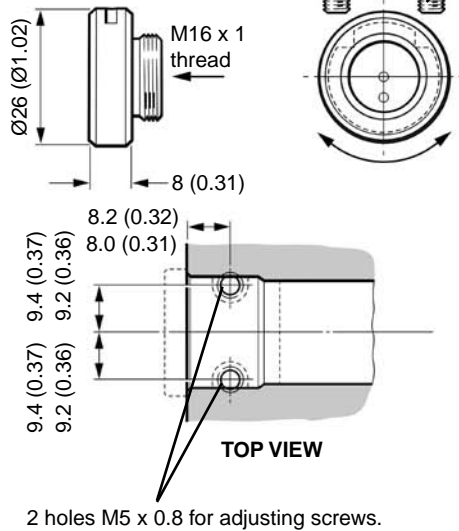

Machining details for mounting hole (FS1)

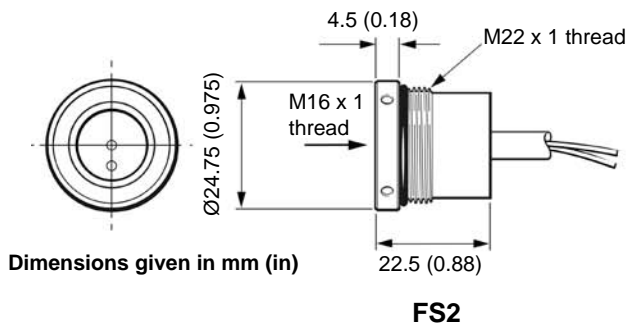
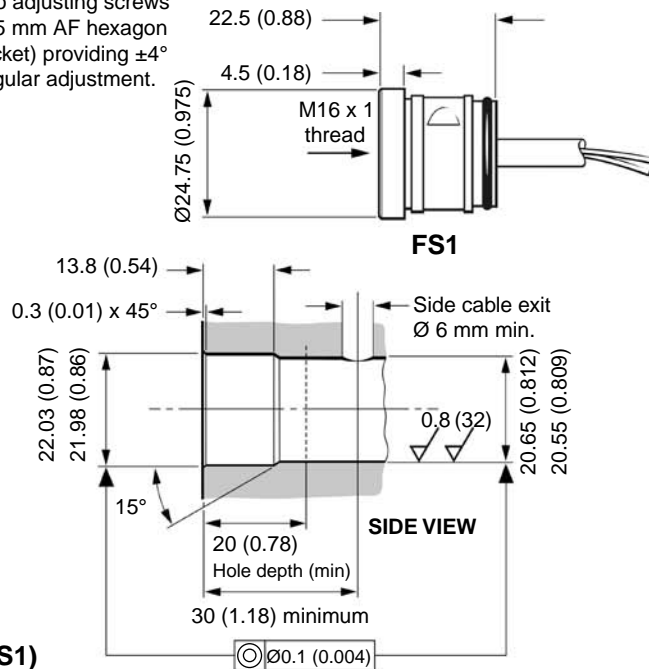

Dimensions given in mm (in)

FS2

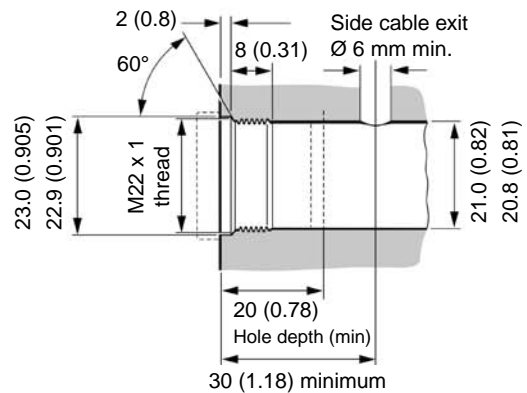

Machining details for mounting hole (FS2)

Minimum cable bend radius	
Static	9 mm
Dynamic	22 mm

Mounting the MP250 probe onto the probe socket

1. Turn off the power supply to the probe socket.
2. Screw the MP250 into the probe socket.
3. Using the C-spanner (A-2063-7587) supplied, tighten the MP250 to 10 Nm (7.2 lbf.ft).

Aligning the probe's stylus to the machine's axes

1. Fit a square tip stylus to the probe.
2. The square tip of the stylus must align exactly with the machine's X and Y axes. Coarse adjustment is obtained by visually aligning the stylus tip with the machine axes. Fine adjustment ($\pm 4^\circ$) is provided via two rotational adjustment screws acting on the optional FS1 socket.

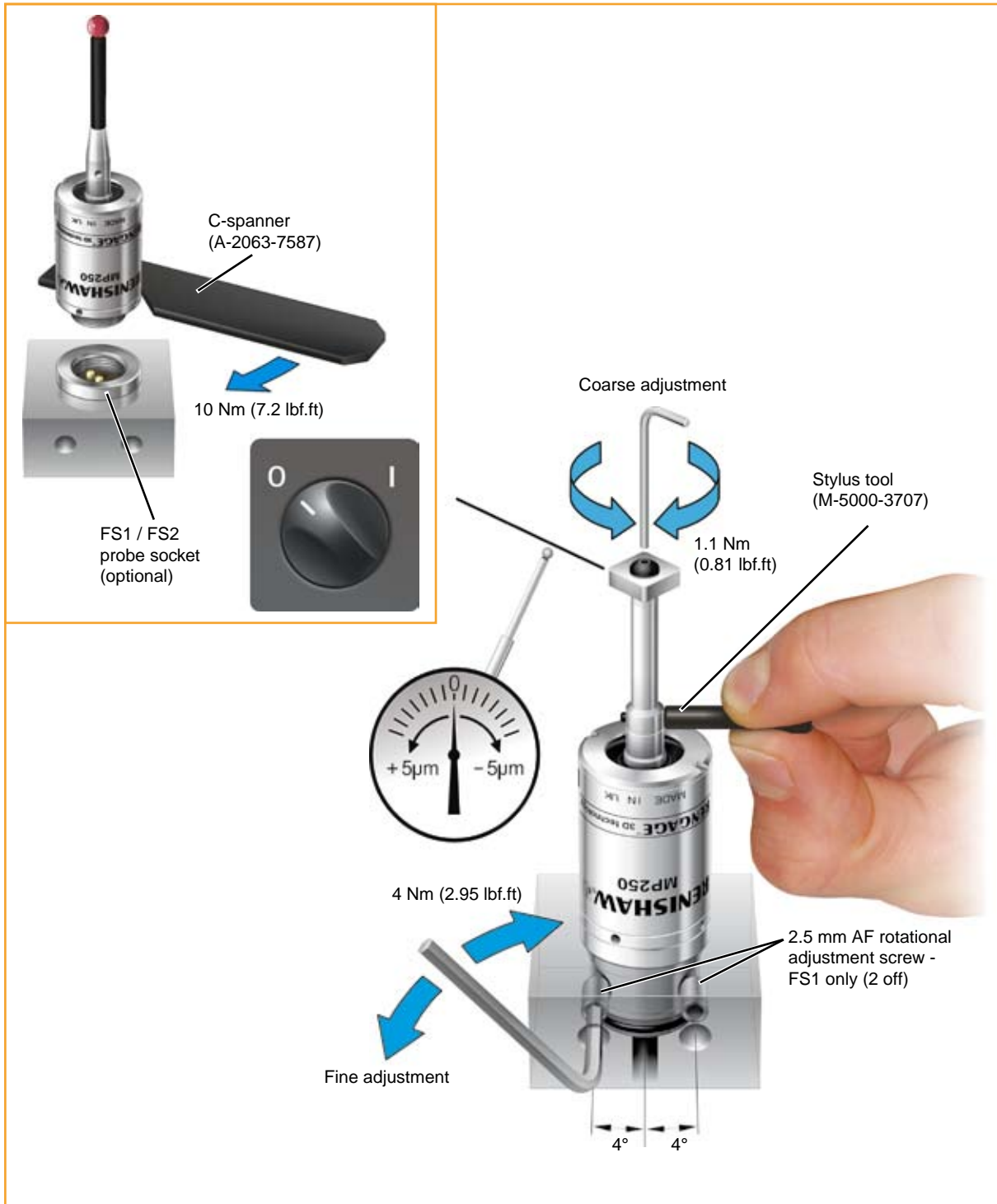

Electrical connections

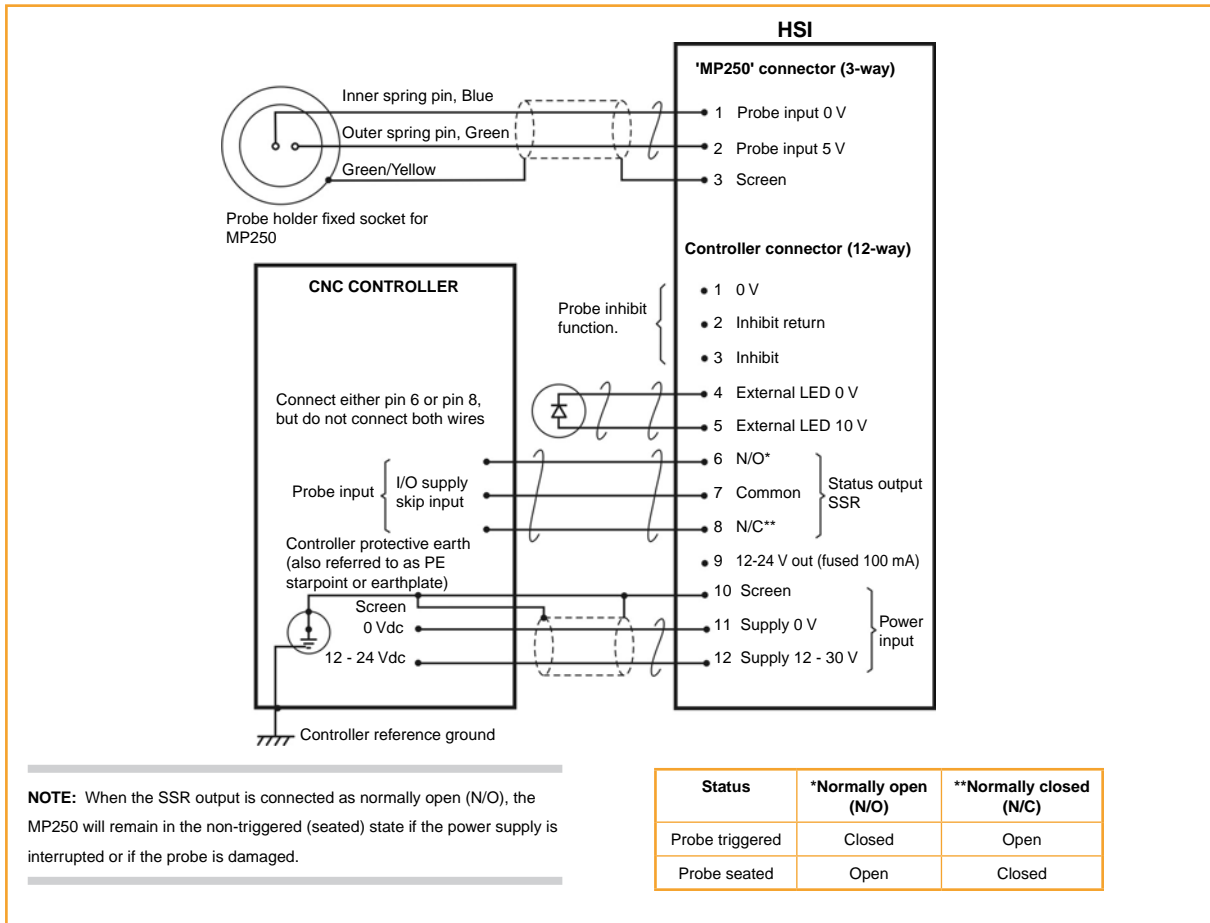

Typical MP250 system installation

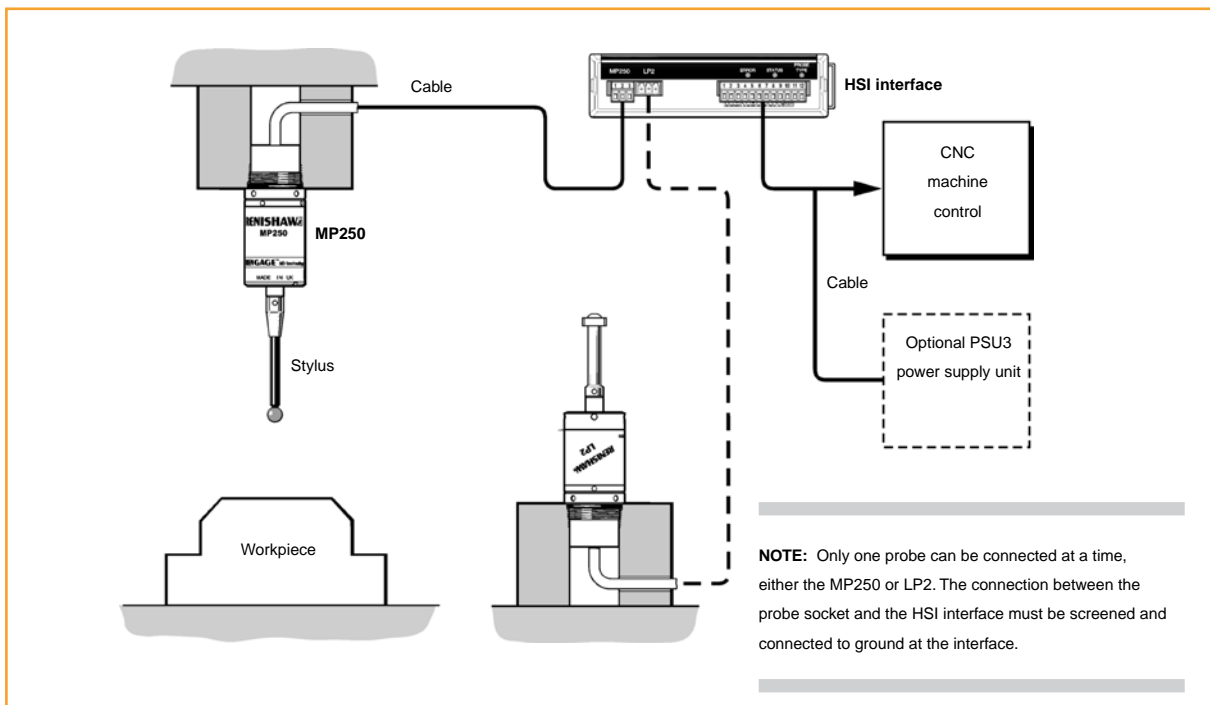

Data sheet

MP250

Diaphragm replacement kit

The probe's mechanism is protected from coolant and debris by two diaphragms which provide adequate protection under normal working conditions. The user should periodically check the outer diaphragm for signs of damage. If this is evident, replace the outer diaphragm. An outer diaphragm replacement kit (A-5500-1650) is available from your supplier. The user must not remove the inner diaphragm. If damaged, return the probe to your supplier.

Re-orientation of the probe

If an MP250 is fitted with a long or heavy stylus, and its orientation is changed from horizontal to vertical or vice-versa (i.e., such as on a 5 axis machine with a swivelling head), it is possible for the probe to trigger and remain triggered requiring a probe reset. It is also possible, if the MP250 is fitted with a long or heavy stylus, mounted horizontally and then rotated about its own axis, for the probe to trigger and remain triggered.

It is recommended that the probe inhibit function is used to turn off power to the MP250 during every re-orientation move. Once the re-orientation move is complete, the probe inhibit function should be removed so that power to the probe is restored. The probe will then take a minimum of 0.4 seconds before it is ready to measure and must remain stationary during this period.

For further details of the probe inhibit function, please refer to the HSI interface installation guide (H-5500-8554).

Switch-on delay

When the probe is switched on, it will become operational in a minimum of 0.6 seconds. To ensure that the probe activates correctly, it is important to make sure that it is stationary when it is switched on. If the probe is not stationary during the start sequence, then there is a possibility that the strain gauges could auto-zero in the incorrect position and produce a permanently triggered output.

NOTES:

The probing program on the machine will need to take account of the switch-on delay.

The stylus must not be deflected when the probe is switched on, otherwise the system will not initialise correctly and may appear permanently triggered.

During the initialisation period just after switch on, the probe status output is triggered for safety reasons.

Enhanced trigger filter

Probes subjected to high levels of vibration or shock loads may output signals without having contacted any surface. The enhanced trigger filter improves the probe's resistance to these effects by introducing a constant 8 ms delay to the probe's output.

NOTE: It may be necessary to reduce the probe's approach speed to allow for increased stylus overtravel during the extended time delay.

Measurement cycles

The probe must be powered off between measurement cycles. The probe inhibit function may be used to turn off power to the MP250 after a measurement cycle is completed.

Before starting a measurement cycle, the probe inhibit function should be removed so that power to the probe will be turned on. The probe will then take a minimum of 0.4 seconds before it is ready to measure and must remain stationary during this period.

During a measurement cycle, the measured point must be taken when the probe triggers (probe status goes from seated to triggered) and not when it reseats (probe status goes from triggered to seated). The performance of the probe when it reseats is not specified.

Trigger speed

The minimum recommended trigger speed is 3 mm/min. If a lower speed is used, it is possible that the probe will not reseat. If this occurs, the probe must be switched off and back on again to reset itself.

NOTES:

Take care when using the machine's handwheel to ensure the probing speed is greater than 3 mm/min.

It is very important that the probe calibration is carried out at the same speed as the measurement speed, as this automatically compensates for the fixed time difference between the stylus touching the part and the machine control reading the scale position.

Principal application

Workpiece measurement and job set-up on tool and cutter grinding machines, wire erosion machines and wheel erosion machines.

Specification - MP250 probe

Dimensions	Length: 40.7 mm (1.60 in) Diameter: 25 mm (0.98 in)	
Weight	64 g (2.26 oz)	
Transmission type	Hardwired transmission using the HSI interface	
Sense directions	Omni-directional $\pm X$, $\pm Y$, $+ Z$	
Uni-directional repeatability	0.25 μm (10 μin) 2 sigma*	
2D lobing in X, Y	$\pm 0.25 \mu\text{m}$ (10 μin)*	
3D lobing in X, Y, Z	$\pm 1.00 \mu\text{m}$ (40 μin)*	
Stylus trigger force XY plane + Z direction	0.08 N, 8 gf (0.29 ozf) typical minimum 2.6 N, 270 gf (9.4 ozf) typical minimum	The stylus trigger force is the force exerted on the component when the probe triggers. However, the maximum force applied to the component will occur after the trigger point and will be greater than the trigger force. The magnitude depends on a number of factors affecting probe overtravel including measuring speed and machine deceleration. If the forces applied to the component are critical, contact Renishaw for further information.
Stylus overtravel force XY plane + Z direction	0.70 N, 70 gf (2.5 ozf) typical minimum § 5.0 N, 510 gf (18 ozf) typical minimum †	
Stylus overtravel XY plane + Z direction	$\pm 13^\circ$ 6.5 mm (0.26 in)	
Minimum trigger speed	3 mm/min (0.12 in/min)	
Sealing	IPX8 (BS 5490), IEC 529) 1 atmosphere	
Storage temperature	-10 °C to 70 °C (14 °F to 158 °F)	
Operating temperature	5 °C to 50 °C (41 °F to 122 °F)	

* Performance specification is for a test velocity of 480 mm/min (18.9 in/min) with a 35 mm stylus. Test velocity does not constrain performance in application.

§ Stylus overtravel force in XY plane occurs 50 μm after the trigger point and rises by 0.12 N/mm, 12 gf/mm (11 oz/in) until the machine tool stops (in the high force direction and using a 35 mm stylus).

† Stylus overtravel force in + Z direction occurs 11 μm after the trigger point and rises by 1.2 N/mm, 120 gf/mm (110 oz/in) until the machine tool stops.

Specification - HSI interface

Principal application	Hard-wired transmission interface, which conveys and processes signals between an inspection probe and the CNC machine control
Dimensions	134 mm x 98 mm x 34.6 mm
Mounting	DIN rail
Power supply	12 V to 30 V d.c.
Probe compatibility	The HSI interface is compatible with the following probes: LP2H, LP2, LP2DD, LP2LD and MP250.

Parts list

Please quote part number when ordering equipment.

Type	Part number	Description
MP250	A-5500-1600	MP250 probe with tool kit (C-spanner x 2 and stylus tool) and quick-start guide.
FS1	A-5500-1710	FS1 adjustable probe socket with 10 m of screened cable.
FS2	A-5500-1810	FS2 fixed probe socket with 10 m of screened cable.
HSI	A-5500-1000	HSI interface.
PSU3	A-2019-0018	PSU3 power supply unit.
Swarf deflector	M-2063-8003	Swarf deflector Ø 28.0 mm (protects probe from hot swarf).
Diaphragm replacement kit	A-5500-1650	Outer diaphragm replacement kit.
C-spanner	A-2063-7587	C-spanner.
Stylus tool	M-5000-3707	Tool for tightening / releasing styli.
Styli		For a complete list of styli, please refer to Renishaw's styli and accessories technical specification (H-1000-3200).
Software		For a complete list of probe software for machine tools, please refer to Renishaw's probe software for machine tools - illustrated features data sheet (H-2000-2289).
Terminal block	P-CN25-0008	3-way terminal block.
Terminal block	P-CN47-0032	12-way terminal block.
Publications. These can be downloaded from our web site at www.renishaw.com		
MP250	A-5500-8500	Quick start guide: for rapid setup of the MP250 probe, includes CD with installation guides.
MP250	H-5500-8504	Installation guide: MP250 machine tool probe system.
Styli	H-1000-3200	Technical specification: Styli and accessories.
Software features	H-2000-2289	Data sheet: Probe software for machine tools - illustrated features.
Software list	H-2000-2298	Data sheet: Probe software for machine tools - list of programs.
HSI	A-5500-8550	Quick start guide: includes CD with installation guides.
HSI	H-5500-8554	Installation guide: Hardwired system interface.
PSU3	H-2000-5057	Installation and user's guide: PSU3 power supply unit.

For worldwide contact details, please visit our main website at
www.renishaw.com/contact

