

MicroScale™

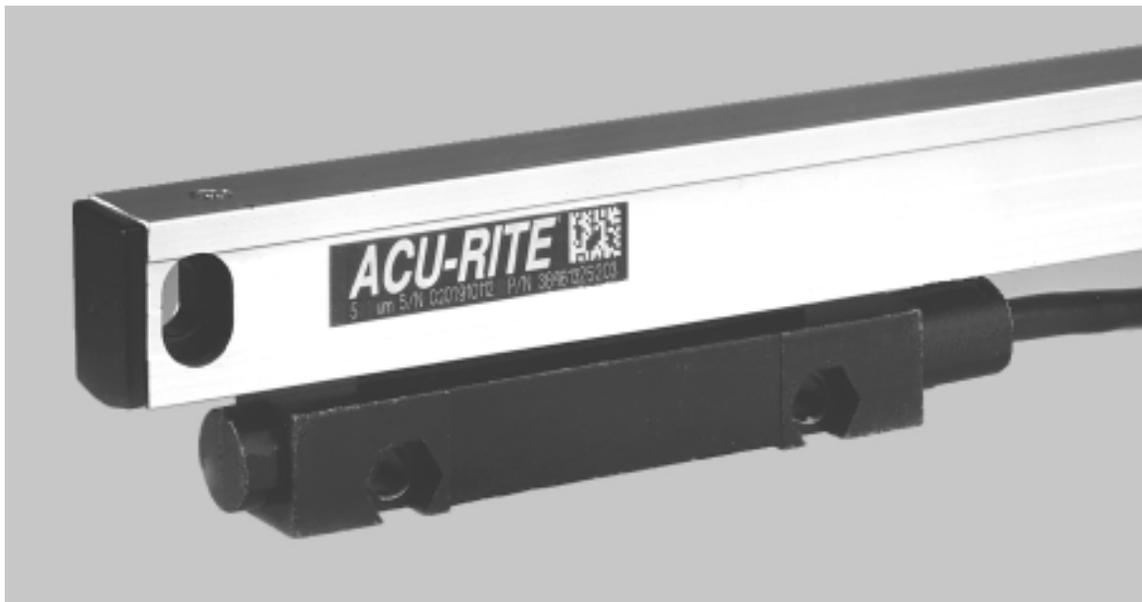

REFERENCE MANUAL

ACU-RITE®

	<i>Page</i>
Introduction / Supplied items	2
Key Points / Tolerances	3
Linear Encoder Dimensions	4
Spar Dimensions	5
Mounting Requirements	6
Typical Mounting	7
Encoder Installation Procedure	8

	<i>Page</i>
Checking the Installation	10
Troubleshooting	11
Mechanical Specifications	12
Output Signals and Pin-Outs	13
Electrical Specifications	14
The ACU-RITE warranty and 30-Day Red Carpet warranty service	15

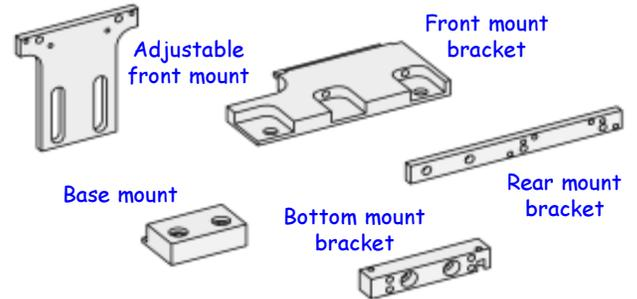
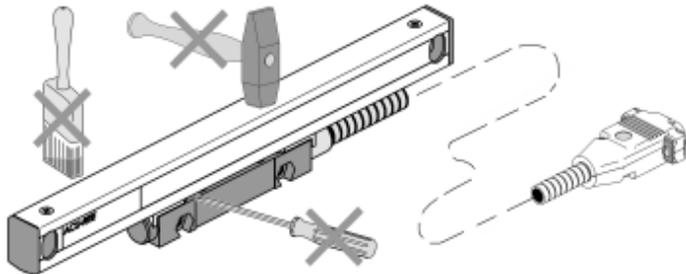

- Installation brackets and kits are available.
- Your Authorized ACU-RITE Distributor can assist you in selecting brackets and tools for your installation.

The MicroScale Precision Glass Scale Linear Encoder provides the accuracy and reliability of an ACU-RITE measuring system in a very small cross-section with digital output (analog output available).

Features and options include:

- Resolutions of 0.5, 1 or 5µm.
- Accuracy grades of ± 3 or $\pm 5 \mu\text{m} / 1000\text{mm}$.
- Position Track.
- Vinyl or Armor cables of 2, 5, 10, 15, & 20 ft. lengths.
- Mounting fasteners, center supports, and backup spar.
- Installation tools, brackets, and accessories.

The MicroScale is especially useful for applications with limited space such as X/Y stages and compact metrology equipment. Contact your ACU-RITE Distributor for assistance with selection of product options and accessories.

For future ordering information or warranty service, record the linear encoder catalog and serial numbers.

	Catalog #	Serial #
Axis # 1:	_____	_____
Axis # 2:	_____	_____
Axis # 3:	_____	_____
Axis # 4:	_____	_____
Date of Purchase	_____	
Distributor:	_____	
Address:	_____	
Telephone:	_____	

Shipping carton contents

MicroScale
1" - 18"

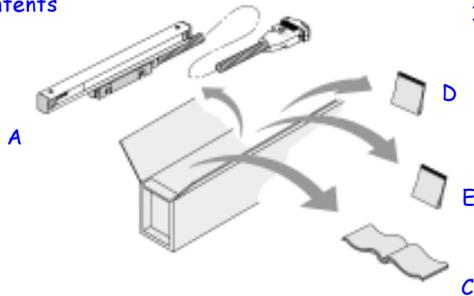

- A) MicroScale linear encoder
- B) Backup Spar
- C) Reference Manual

Shipping carton contents

MicroScale
over 18"

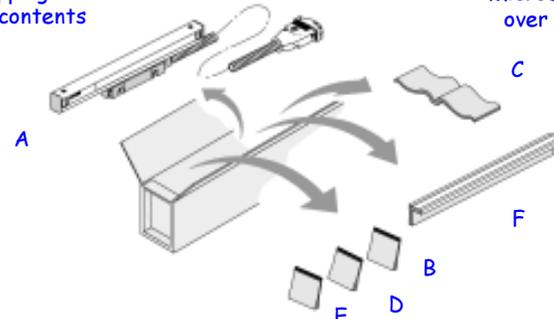

- D) Cable Mounting Hardware
- E) Linear Encoder Mounting Hardware
- F) Backup Spar Mounting Hardware

Use this information to plan your Linear Encoder installation.

- Understand your mounting requirements.
- Follow kit instructions when using an ACU-RITE bracket kit.
- Mount encoders close to ways to insure system accuracy.
- Mount with lip seals down and away from the work area.
- Brackets should be short and rigid.
- Surfaces must be in good condition, clean and free of dirt and paint.
- **⚠ Do not remove shipping brackets until instructed.**
- Shipping bracket spacers can be used to insure .059" gap.
- Mount from either side to obtain desired cable exit direction.

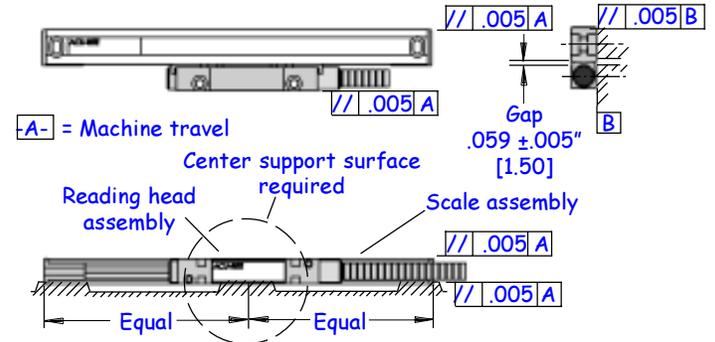

- Tolerances of .005" TIR apply to all mounting dimensions.
- **Center support surface required for all measuring lengths when not using a back up spar.**

Shipping bracket removal clearance

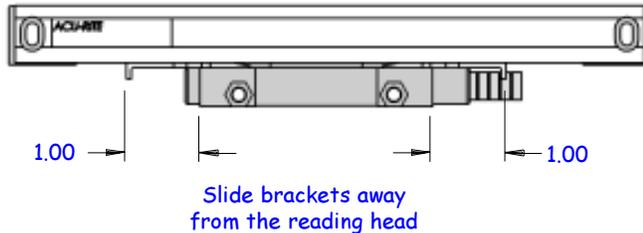

- Allow clearance for shipping bracket removal.

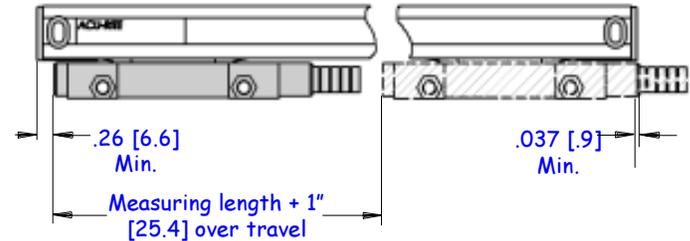

- Limit equipment travel to less than measuring length.

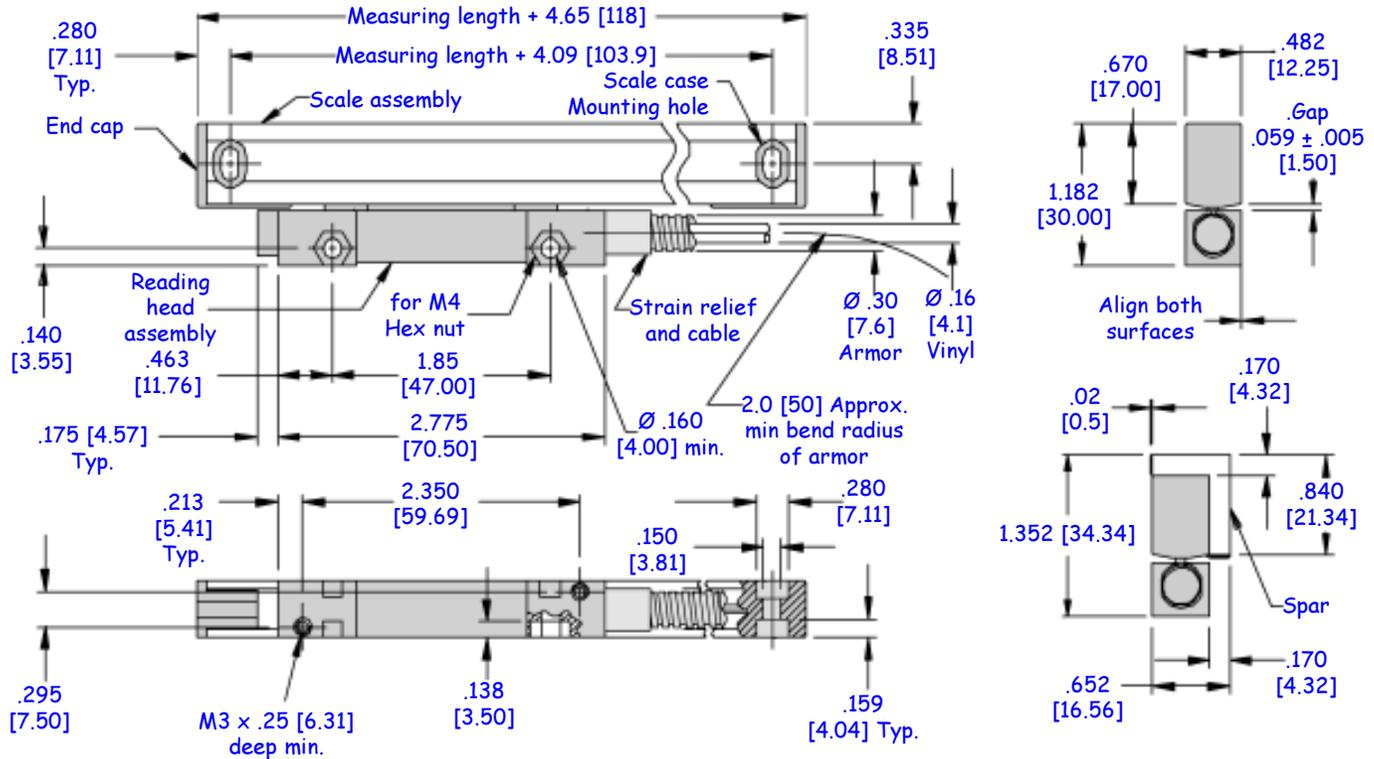

Backup spar Part Number	Linear Encoder Measuring Length	L	A	X No. Places	B
384611-101	1	5.650	.825	2	4.000
384611-102	2	6.650	.825	2	5.000
384611-103	3	7.650	1.325	2	5.000
384611-104	4	8.650	1.825	2	5.000
384611-105	5	9.650	2.325	2	5.000
384611-106	6	10.650	2.825	2	5.000
384611-107	7	11.650	3.325	2	5.000
384611-108	8	12.650	3.825	2	5.000
384611-109	9	13.650	1.825	3	5.000
384611-110	10	14.650	2.325	3	5.000
384611-111	11	15.650	2.825	3	5.000
384611-112	12	16.650	3.325	3	5.000
384611-113	13	17.650	3.825	3	5.000
384611-114	14	18.650	1.825	4	5.000
384611-116	16	20.650	2.825	4	5.000

Backup spar Part Number	Linear Encoder Measuring Length	L	A	X No. Places	B
384611-118	18	22.650	1.325	3	10.000
384611-120	20	24.650	2.325	3	10.000
384611-122	22	26.650	3.325	3	10.000
384611-124	24	28.650	4.325	3	10.000
384611-126	26	30.650	5.325	3	10.000
384611-128	28	32.650	1.325	4	10.000
384611-130	30	34.650	2.325	4	10.000
384611-132	32	36.650	3.325	4	10.000
384611-136	36	40.650	5.325	4	10.000
384611-140	40	44.650	2.325	5	10.000
384611-144	44	48.650	4.325	5	10.000
384611-148	48	52.650	1.325	6	10.000
384611-152	52	56.650	3.325	6	10.000
384611-156	56	60.650	5.325	6	10.000
384611-160	60	64.650	2.325	7	10.000

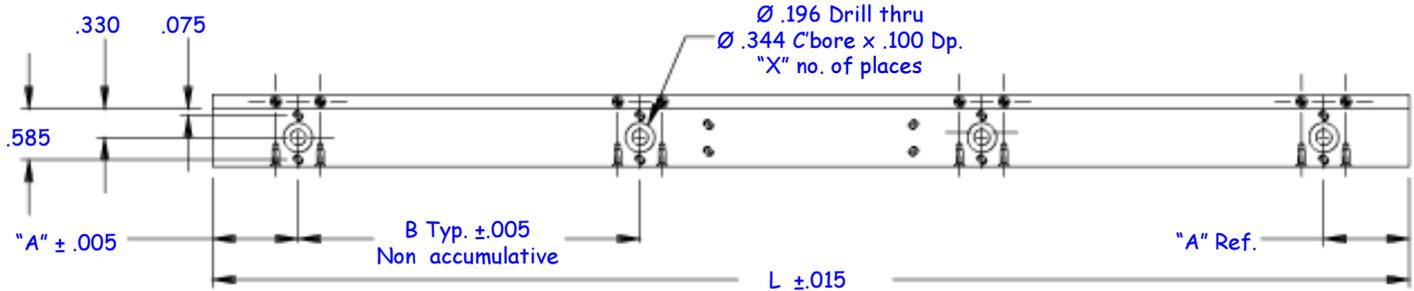

Mounting options can be adapted to machine mounting surfaces using spacers, standoffs, and leveling screws.

- Measuring length and mechanical configuration of your equipment determines your options.
- Length related mounting options shown.
- Backup spar mounting optional for all lengths 18" or less.
- Mount the backup spar following the same procedure as required for mounting without a backup spar, using the same tolerances.

Center support assembly

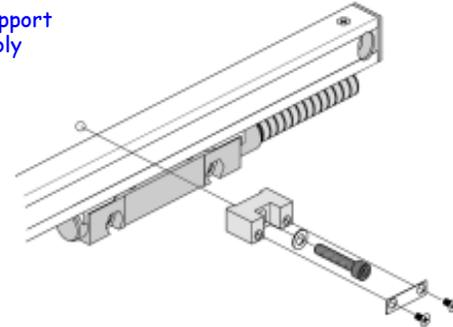

- 8" to 18": End mounting holes with center support.

End mounting holes

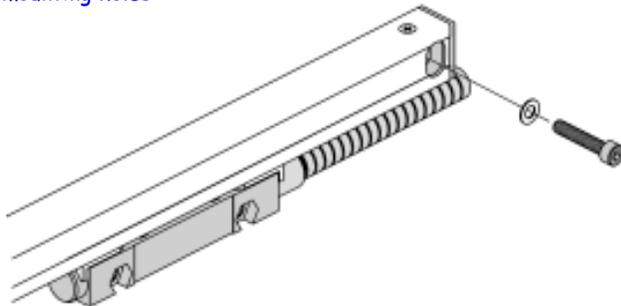

- 7" and smaller: End mounting holes with encoder mounted to a continuous flat surface, or with center surface on same plane as end mounting surfaces.

Backup spar mounting

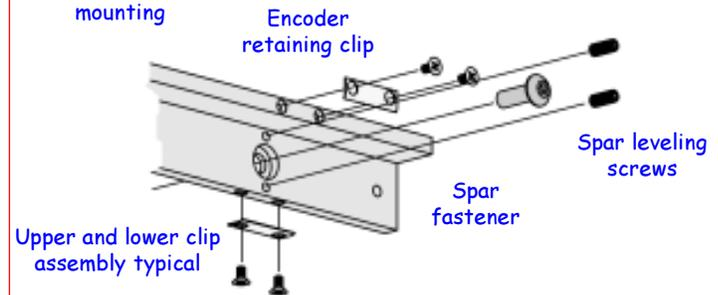

- 20" and longer: Backup spar required.

A variety of mounting conditions can be accommodated.

- Mechanical configuration of the equipment determines brackets and adapters required to install the linear encoder.
- Three typical conditions are shown for reference.

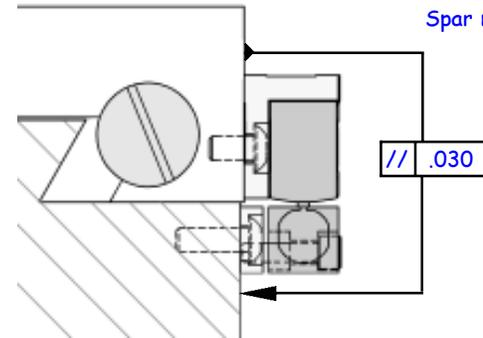

- Flush or offset mounting surfaces using a spar.
- Reading head mounting bracket required (mounting plate example shown).

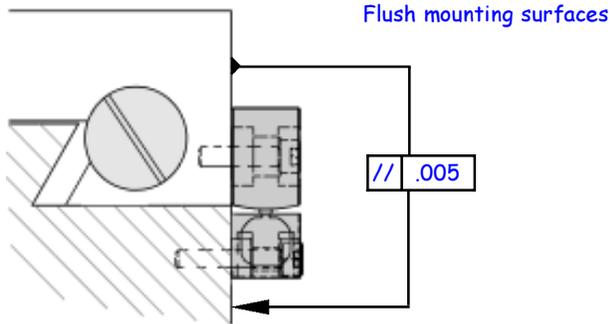

- Mounting surfaces are flush within $.005''$.
- Installation without a backup spar.

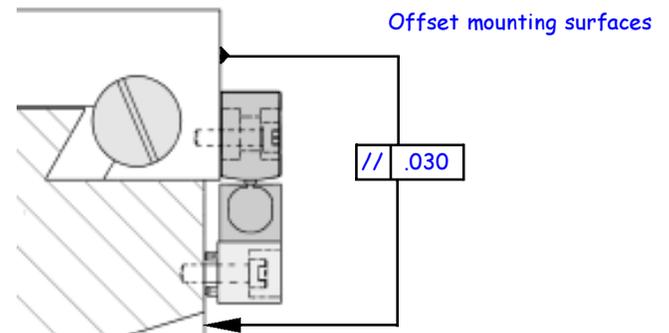

- Offset mounting surfaces using a reading head bracket.

These steps apply to all mounting conditions. Although this may not pictorially represent your application, your installation procedure should follow these steps.

- **⚠ ACU-RITE Bracket Kit instructions supercede this section.**
- General steps for small X & Y stage.
- Adjust drill depths and fastener lengths as required.
- Contact your Authorized ACU-RITE Distributor if assistance is required.

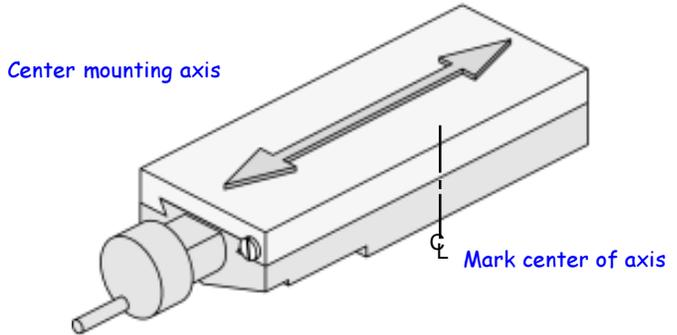

- Center the axis.
- Mark the axis for easy return to center.

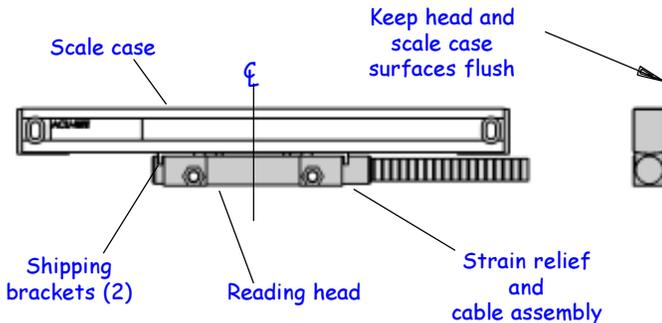

- Center the reading head on the scale case by sliding the head and shipping brackets together along the scale case.

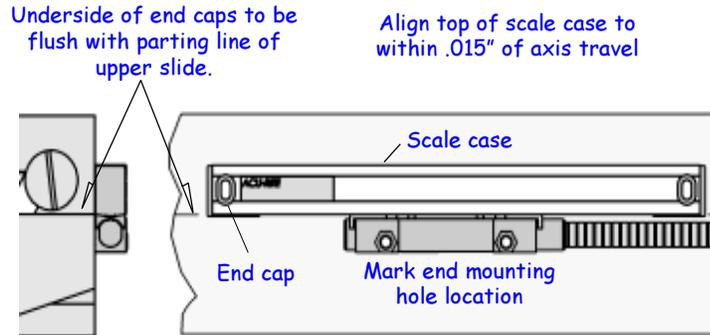

- Locate the linear encoder along the axis parting line.
- Mark location of one end mounting hole in the scale case.

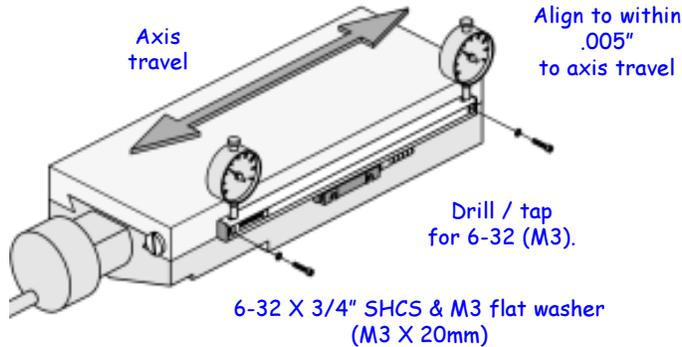

- Drill / tap the first end mounting hole / Attach the scale case.
- Align to within .005" TIR. and drill / tap second end hole.
- Attach scale case & align to within .005" TIR. of the axis travel.

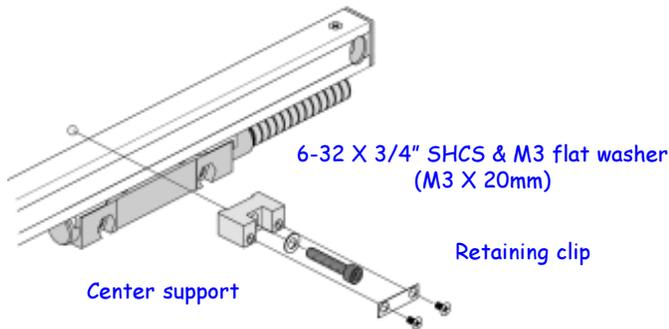

- Use center supports when provided.
- Place at uniform intervals along the scale case.

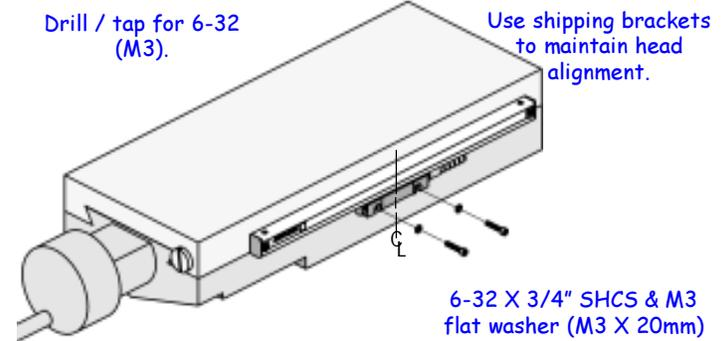

- Center the axis and mark the reading head mounting holes.
- Move the axis and drill / tap holes for 6-32 (M3).
- Attach head and align to scale case to within .005" TIR.

Slide bracket from reading head and twist 45°

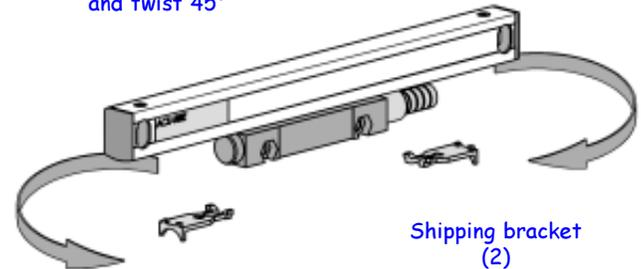

- Slide shipping brackets from reading head and twist to remove from the scale case.
- Save the shipping brackets with the Reference Manual.

Connecting

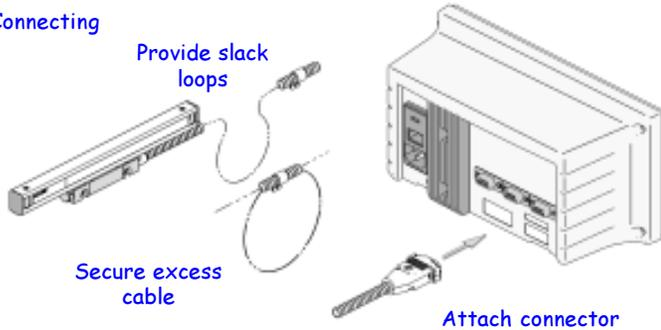

- Route the cables with slack loops to allow for axis motion.
- Secure excess cable by fastening with clips or ties.
- Attach the linear encoder connectors to the readout.

Counting Test

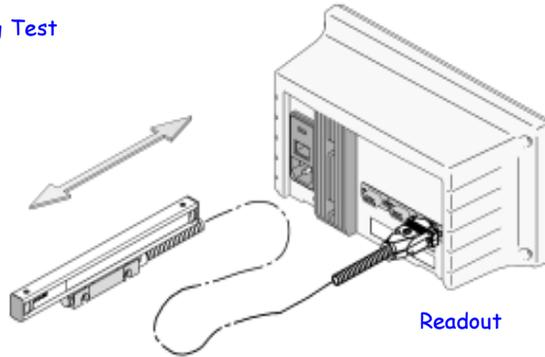

- Check function of the linear encoder.

These steps will confirm proper operation of your installation. Counting tests check channel A and B output function and Reference Mark tests check Reference Mark operation.

- Configure the readout for proper counting resolution.
- Move axis and compare the display to the movement.
- Repeat test for mechanical integrity and repeatability.
- Configure the readout for sensing reference mark.
- Move the reading head approximately 20mm.
- Locate an indicator on scale end and zero out axis and indicator.
- Move axis out and back over full travel and return to dial zero.
- Electronics should read zero \pm 1 count.

Place indicator at end of moving component (scale case shown, or reading head).

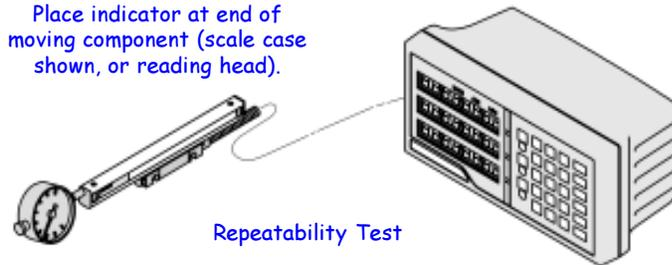

- Zero the display and indicator.
- Move axis to the end of it's travel, then return to dial zero.
- Readout should read zero \pm 1 count.

If you experience difficulties with your installation, there are methods to analyze the difficulty. Operating difficulties can be caused by either the linear encoders or the readout.

Checking the readout

Follow the steps below to determine if your difficulties are associated with the readout:

- Insure that the linear encoder connectors are correctly seated.
- Swap linear encoder cables at the readout to see if the problem is still shown in the same display.
- If the problem remains in the same display, the readout is in error.
- If the problem follows the connection change, the linear encoder may be in error.
- Follow this procedure for any intermittent problem experienced.

If the readout is at fault, refer to “**What to do**” to arrange for the parts necessary to repair your system. If the linear encoders appear to be the cause, perform the next step.

Checking the Linear Encoders

Linear encoder difficulties can be caused by improper installation, loose or misaligned bracketry, or a damaged / failed linear encoder.

Follow the steps below to determine the cause of your system difficulties:

- Confirm that your bracketry and installation does not interfere

with other machine structures through the length of the linear encoder travel.

- Check for loose fasteners. If you find loose fasteners, first confirm that the linear encoder is installed to the tolerances specified and then retighten the fasteners as required.
- Confirm that the linear encoder is installed to the required tolerances by checking the alignment tolerances specified on Page 3 “**Key Points**”. If the installation does not meet the tolerances, reinstall the linear encoder according to the procedures in “**Installation**”.
- Perform a Repeatability Test as described on Page 10, “**Checking Your Installation**”. If the linear encoder is installed to the required tolerances, the bracketry and linear encoder have been checked for interferences and loose fasteners, and the linear encoder fails the repeatability test, the linear encoder is likely at fault.

Do not attempt to repair the linear encoder. The units are only serviceable by assembly replacement. Attempted repair can permanently damage the unit and void the warranty.

What to do

If an ACU-RITE linear encoder or readout is found to be at fault, prior to removing the linear encoders or readout contact your Authorized ACU-RITE Distributor or OEM/OEI for repair instructions.

Mechanical Specifications	Digital			Analog
Resolution	0.5µm	1µm	5µm	
Grating pitch	20µm			
Scale medium	Light transmission through chrome-coated glass			
Accuracy (@ 20° C) / 1000mm	± 3µm, ± 5µm			
Max. slew speed (inches/sec) @ 10° C to 30° C @ 0° C to 40° C	40 21			
Force required to move reading head	≤ 0.5 (lbs)			
Operating Environment Temperature Relative Humidity	0° to 40° C 20% to 95% (non-condensing)			
Storage Environment Temperature Humidity	- 40° to 65° C 20% to 95% (non-condensing)			
Weight (lbs)	1.1 + 0.12/ft of measuring length			
Connecting cable armored or vinyl	Length = 5, 10, 15, and 20 ft. Connector: DE-9P or Bendix PTO 6A-10-6P (or Cannon, Burndy equivalent)		Length = 2, 5, 10, 15, and 20 ft. Connector: DE-9P	
Max. cable length (ft)	36		26	
Measuring lengths	1" - 60"			
Reference pulse interval	100mm fixed or Position Track			
Repeatability	Within one resolution count			

Digital Differential

Pin 1	Pin 2	Pin 3	Pin 4	Pin 5	Pin 6	Pin 7	Pin 8	Pin 9
N/C	Green	Yellow	Blue	Red	White	Brown	Pink	Gray
N/C	Channel A+	Channel A-	Channel B+	Channel B-	Ground	Vcc, + 5.1 ± 0.1 VDC @ 140mA max.	Channel R+	Channel R-

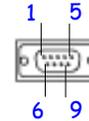
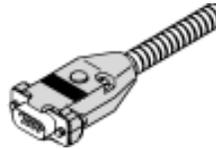

Analog Differential

Pin 1	Pin 2	Pin 3	Pin 4	Pin 5	Pin 6	Pin 7	Pin 8	Pin 9
N/C	Green	Yellow	Blue	Red	White	Brown	Pink	Gray
N/C	Channel A+	Channel A-	Channel B+	Channel B-	Ground	Vcc, + 5.1 ± 0.1 VDC @ 140mA max.	Channel R+	Channel R-

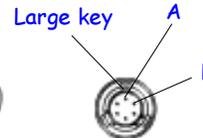

Digital single ended

Pin A	Pin B	Pin C	Pin D	Pin E	Pin F
Green	Blue	Brown	White	Drain	Pink
Channel A	Channel B	Vcc, + 5.1 ± 0.1 VDC @ 140mA max.	Common (power supply and return signal return)	Shield, reading head casting ground	Channel R (Reference Mark)

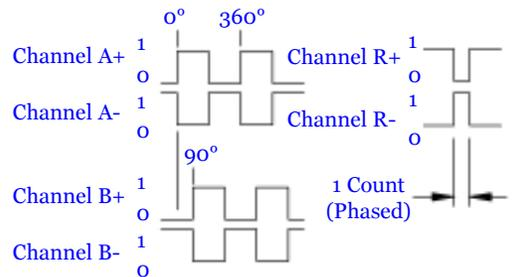
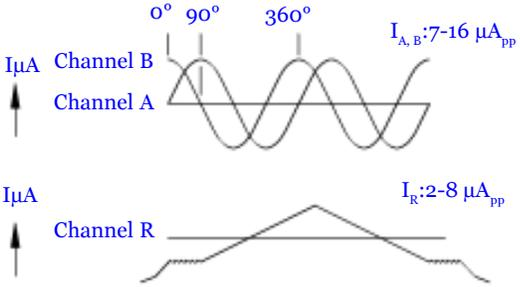
Parameter	Digital	Analog
Output Signals	<p> I_{OH}=(High level output current) = 20mA V_{OH}=(High level output voltage) >2.5Vdc  I_{OL}=(Low level output current) = -20mA V_{OL}=(Low level output voltage) >0.5Vdc For Single Ended output only A+, B+, and R+ apply </p>	
Incremental signals	Square-wave voltage signals.	Similar phasing, but differential
Signal levels	Channels A and B, in 90° quadrature relationship TTL-level	sinusoidal current output
Reference Mark signals	Square-wave signal	7-16 μ A _{pp} w/1 K Ohm load
Signal level	TTL-level	Differential current output 2-8 μ A _{pp} w/100 K Ohm load
Power Supply	5.1 ± 0.1 VDC @ 140 mA max.	5.0 ± 0.1VDC @ 80 mA max.

ACU-RITE products and accessories are warranted against defects in material and workmanship for a period of three years from the date of purchase. ACU-RITE will, at its option and expense, repair or replace any part of the ACU-RITE product which fails to meet this warranty. This warranty covers both materials and factory service labor. In addition, authorized ACU-RITE service representatives will provide service labor (field service) for a one-year period at no charge. Notice of the claimed defect must be received by ACU-RITE within the warranty period.

This warranty applies only to products and accessories installed and operated in accordance with this reference manual. ACU-RITE shall have no obligation, with respect to any defect or other condition caused in whole or part by the customer's incorrect use, improper maintenance, modification of the equipment, or by the repair or maintenance of the product by any person except those deemed by ACU-RITE to be qualified.

Responsibility for loss of operation or diminished performance due to environmental conditions such as humidity, dust, corrosive chemicals, deposition of oil or other foreign matter, spillage, or other conditions beyond ACU-RITE's control can not be accepted by ACU-RITE.

There are no other warranties expressed or implied, and ACU-RITE INCORPORATED shall not be liable under any circumstances for consequential damages.

30 Day Red Carpet warranty service

Keep the box and packing materials

All ACU-RITE products are covered by a 30-day Red Carpet Warranty Service. If in the first 30 days this product fails for any reason, repack it in the original packing materials and contact your Authorized ACU-RITE Distributor for return instructions.

Notes

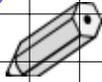

**ACU-RITE IS AN
ISO 9001
CERTIFIED
MANUFACTURER**



ACU-RITE[®]

ACU-RITE COMPANIES INC.
One Precision Way • Jamestown, NY 14701

384601-004 EDITION G 2/03

