



HEIDENHAIN



Digital Readouts

Linear Encoders

For Manually Operated
Machine Tools

September 2012

Digital readouts from HEIDENHAIN are used in a wide variety of applications. These include machine tools, infeed axes (e.g. on saws and presses), measuring and inspecting equipment, dividing apparatuses, setting tools, and measuring stations for production control. In order to meet the requirements of these applications, many encoders from HEIDENHAIN can be connected to the digital readouts.

The main application for digital readouts with two or more axes is on manually operated machine tools. Whether milling, drilling, boring or turning, the field-proven cycles provide the operator with optimal support. Digital readouts show the current position quickly and clearly, enabling a significant increase in work productivity. The most important linear encoders for position measurement on manually operated machine tools are also listed in this brochure.

You can find other encoders for connection to the digital readouts on the Internet at www.heidenhain.de, or in the *Linear Encoders for Controlled Machine Tools*, *Length Gauges*, *Angle Encoders* and *Rotary Encoders* product brochures.



Contents

| Digital readouts | | | |
|---|--|--|-----------|
| Overview | HEIDENHAIN digital readouts | | 4 |
| | Selection guide | | 6 |
| Functions | Metrological and statistical functions (ND 287) | | 8 |
| | Probing functions for datums (ND 780, POSITIP, ND 1200R) | | 10 |
| | Tool compensation (series ND 500, ND 780, POSITIP) | | 11 |
| | Distance-to-go display (all digital readouts) | | 12 |
| | Hole patterns (series ND 500, ND 780, POSITIP, ND 1200R) | | 13 |
| | Contour monitoring (ND 500, POSITIP) | | 14 |
| | Rectangular pockets (POSITIP) | | 14 |
| | Help when working with lathes (series ND 500, ND 780, POSITIP) | | 15 |
| | Programming of machining steps (POSITIP, ND 1200R) | | 16 |
| | For fast and standard radial drills (ND 1200R) | | 17 |
| Specifications | ND 200 series – universal digital readouts for one axis | | 18 |
| | ND 500 series – straightforward display units for two and three axes | | 20 |
| | ND 780 – adaptable digital readout for up to three axes | | 22 |
| | POSITIP 880 – the programmable digital readout for up to six axes | | 24 |
| | Series ND 1200R – digital readouts for conventional and fast radial drilling machines | | 26 |
| Mounting | | | 28 |
| Electrical connection | Encoders | | 33 |
| | Interfaces | | 35 |
| | Accessories | | 46 |
| | Cable overview | | 47 |
| Linear encoders for manually operated machine tools | | | |
| Overview | | | 50 |
| Mounting information | | | 52 |
| Specifications | LS 300 series | | 54 |
| | LS 600 series | | 56 |
| Electrical connection | Interfaces | Incremental signals \sim 1 V _{PP} | 58 |
| | | Incremental signals \square TTL | 60 |
| | Connecting elements and cables | | 62 |

HEIDENHAIN digital readouts

– Designed for the real world

HEIDENHAIN digital readouts have universal application: In addition to standard tasks on milling, drilling and boring machines and lathes, they also offer ideal solutions for many applications on machine tools, measuring and testing equipment, and special machines—in fact all machines where axis slides are traversed manually.



Versatile, ergonomic, and well thought-out

Digital readouts from HEIDENHAIN are designed for user friendliness.

Typical characteristics:

- Highly readable graphic display
- Graphic support and help functions
- Conversational user guidance
- Simple, logically arranged keypad helps you quickly master the available functions and enter positions reliably and rapidly
- Ergonomically designed push-button keypad with symbols that withstand years of use
- Splash-protected front panel prevents damage to the display unit from coolant
- Sturdy cast-metal housing built for the worst of day-to-day workshop conditions



– Operational advantages

Fast

HEIDENHAIN digital readouts save you time. The distance-to-go display feature allows you to approach the next nominal position quickly and reliably, simply by traversing to a display value of zero. Datums can be set wherever needed. This simplifies positioning, especially for workpieces with complicated dimensions.

When milling or boring hole patterns or rectangular pockets, the geometric data can be entered simply and quickly. You move the axis to target positions with the distance-to-go display.

On lathes, the sum display feature for saddle and top slide contributes to more accurate positioning. If taper dimension data are not complete, the display will help the operator to calculate the angles.

The POSITIP is ideal for small-batch production, because repetitive machining sequences can be stored as programs and then used as often as required.

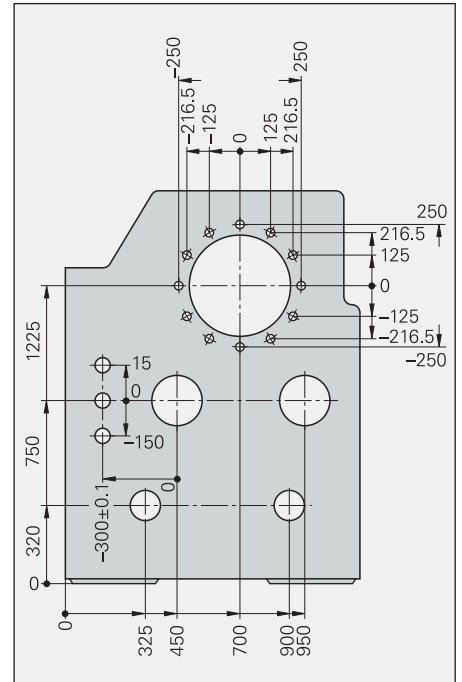

Reliable

A highly readable display shows the measured positions with respect to the selected datum. As a result, the probability of error is reduced and machining becomes more reliable.

The graphic positioning aid of the POSITIP, ND 780 and ND 52x improves the speed and reliability of the distance-to-go display. Graphic illustrations help you to enter the geometric data correctly.



Accurate

On older machine tools, precise machining in the range of 0.01 mm is a matter of luck, since worn machine elements make exact dial and vernier settings impossible. Linear encoders from HEIDENHAIN sense machine slide movement directly. The backlash caused by mechanical transfer elements such as lead screws, racks and gears therefore has no influence. By determining the slide position directly, you achieve higher machining accuracy and reduce scrap rates.



Selection guide

| | Number of axes | Reference points/ Tool data | Functions |
|---|----------------|---|--|
| ND 200 series Digital readouts for measuring devices, adjustment and testing equipment, automated tasks, as well as simple infeed and positioning tasks with one axis <ul style="list-style-type: none"> • Monochrome (ND 280) or color screen (ND 287) • Splash-proof full-travel keyboard • Switching inputs/outputs (ND 287) | 1 | 2 datums | – <ul style="list-style-type: none"> • Distance-to-go display • Metrological and statistical functions (sorting and tolerance checking, measurement series, SPC) • Offsetting a second encoder (optional) for sum/difference display, temperature compensation |
| ND 500 series Digital readout for milling, drilling and boring machines, as well as lathes, with two or three axes <ul style="list-style-type: none"> • Monochrome screen • Membrane keyboard | 2 | 10 datums; 16 tools | <i>General:</i> <ul style="list-style-type: none"> • Distance-to-go display with graphic positioning aid • Contour monitoring <i>Milling and drilling:</i> <ul style="list-style-type: none"> • Hole patterns (circular and linear patterns) • Tool compensation <i>Turning:</i> <ul style="list-style-type: none"> • Radius/diameter display • Separate and sum display |
| | 3 | | |
| ND 780 Digital read out for milling, drilling and boring machines, as well as lathes, with up to three axes <ul style="list-style-type: none"> • Monochrome screen • Splash-proof full-travel keyboard • Switching inputs/outputs (via IOB 49) | Up to 3 | 10 datums; 16 tools | <i>General:</i> <ul style="list-style-type: none"> • Distance-to-go display with graphic positioning aid <i>Milling and drilling:</i> <ul style="list-style-type: none"> • Hole patterns (circular and linear patterns) • Tool compensation • Probing functions for datums <i>Turning:</i> <ul style="list-style-type: none"> • Radius/diameter display • Separate and sum display • Constant surface speed (via IOB 49) |
| POSITIP 880 Digital read out for milling, drilling and boring machines with up to six axes , as well as lathes <ul style="list-style-type: none"> • Color screen • Program memory • Splash-proof full-travel keyboard • Switching inputs/outputs (via IOB 89) | Up to 6 | <i>Milling and drilling:</i> 99 datums; 99 tools <i>Turning:</i> 1 datum; 99 tools | <i>General:</i> <ul style="list-style-type: none"> • Distance-to-go display with graphic positioning aid • Contour monitoring • Programming of machining steps <i>Milling and drilling:</i> <ul style="list-style-type: none"> • Hole patterns (circular and linear patterns) • Tool compensation • Probing functions for datums • Roughing out rectangular pockets <i>Turning:</i> <ul style="list-style-type: none"> • Radius/diameter display • Separate and sum display • Turning with allowances • Multipass cycle |
| ND 1200R RADIAL-DRILL series Digital readouts for fast and conventional radial drills <ul style="list-style-type: none"> • Monochrome screen • Full-travel keyboard • Switching inputs | 2 | 1 datum | <ul style="list-style-type: none"> • Conversion of Cartesian coordinates (X,Y) to polar coordinates (R,A) • XY/RA switch-over • Distance-to-go display in machine coordinates R and A • Hole patterns (circular and linear patterns) • Probing functions for workpiece orientation and datums |
| | 3 | | |

| Encoder inputs | Switching I/O | Data interface | Model | Page |
|--|--|---|------------------|-----------|
| \sim 1 V _{PP} \sim 11 μ A _{PP} EnDat 2.2 | – | RS-232-C/V.24 USB | ND 280 | 18 |
| | Yes | RS-232-C/V.24 USB Ethernet (option) | ND 287 | |
|  TTL | – | USB | ND 522 | 20 |
| | | | ND 523 | |
| \sim 1 V _{PP} \sim 11 μ A _{PP} | <ul style="list-style-type: none"> • For KT edge finder • For edge finder with contact triggering • Additional via IOB 49 | RS-232-C/V.24 | ND 780 | 22 |
| \sim 1 V _{PP} \sim 11 μ A _{PP} EnDat 2.1 | <ul style="list-style-type: none"> • For KT edge finder • Additional via IOB 89 | RS-232-C/V.24; Centronics | PT 880 | 24 |
| \sim 1 V _{PP}  TTL | <ul style="list-style-type: none"> • Zero reset • Measured value output • For KT edge finder | RS-232-C/V.24 USB | ND 1202 R | 26 |
| | | | ND 1203 R | |



Functions

– Metrological and statistical functions (ND 287)

Sorting and tolerance checking

With the sorting function, workpieces can be inspected for dimensional accuracy and divided into classes. To do so, the ND 287 compares the displayed measured value with an upper and lower limit value previously entered with the keypad. The result (whether the measured value is below, above or within tolerance) is indicated in color in the status display as a value or with one of the symbols <, = or >. In addition, a corresponding signal is available at the switching outputs.

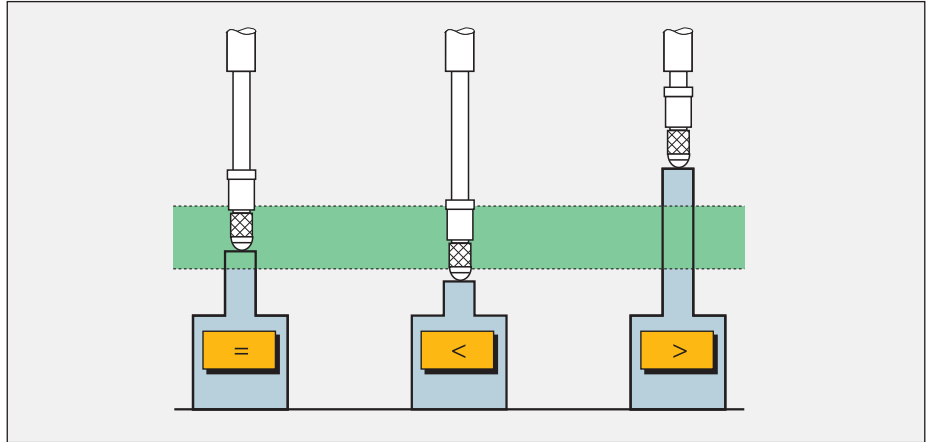

Workpiece sorting

Combination with a second encoder

A second encoder or a sensor on the ND 287 can be connected through an optional **encoder module** or **analog module** input assembly. The data from two encoders can be combined through mathematical operands. Like the two measured values, the result is saved in the measured value memory. This opens further areas of application:

Sum/difference display

The ND 287 calculates the sum or difference of the two measured values, or uses an entered formula, and displays the result. Both measured values can also be displayed individually.

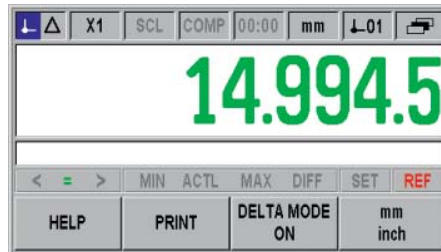

“Within tolerance”

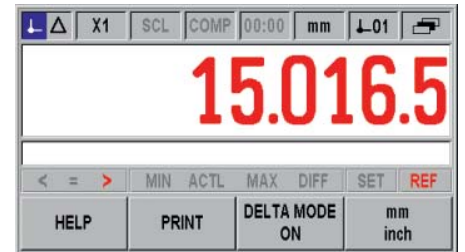

“Out of tolerance”

Temperature compensation

An analog temperature sensor detects the temperature of the measured object. On the basis of the entered temperature coefficients, the ND 287 calculates the compensated length value of the measured object.

Display freeze

To be able to read the display reliably in spite of quickly changing values you can send an external signal to hold the display. The true position value is counted internally. While the display is frozen, the unit is updated with every signal to the new measured value and the frozen/concurrent display is frozen only for the duration of the external signal.

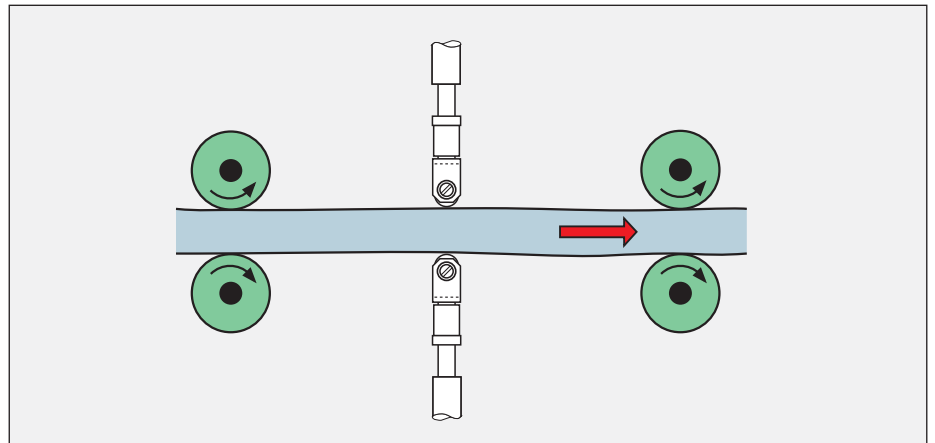

Sum of two length gauges

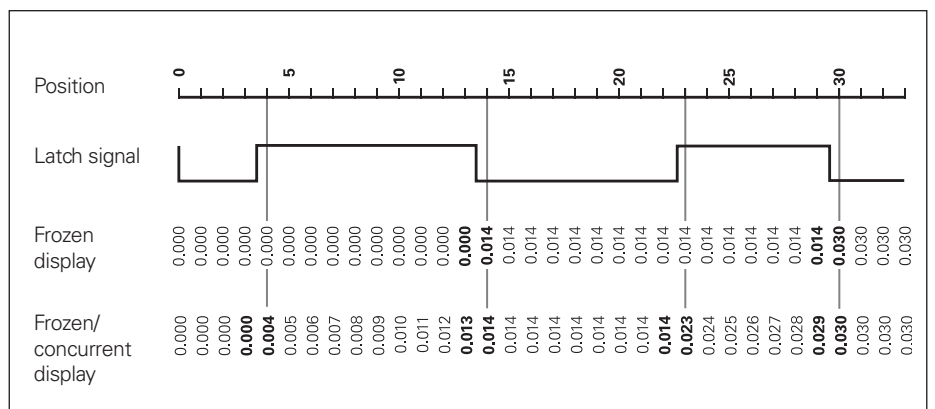

Function of the display freeze features

Measurement series

The ND287 can store measurement series with up to 10000 measured values. The measured values are written by keystroke, over an external command, or cyclically by an internal clock (≥ 20 ms; adjustable). They can be evaluated internally or they can be read out in a block. While the measurement series is running, the display can show the minimum value, maximum value, or the difference of the two instead of the current measured value. In addition, the displayed value can be checked with the classification function for compliance to tolerances.

The stored measured values can be shown and evaluated in different ways.

- **Statistical view** with arithmetic mean, standard deviation and range
- **Diagram** with graphical display of all measured values, minimum/maximum and mean values, and tolerance limits (with activated sorting function).
- **Measured value overview** with tabular view of the measured values.

Statistical process control (SPC)

The ND 287 features functions for statistical process control. Before beginning measurements, the **number** of samples and the measured values per sample are defined and the nominal dimension, **tolerance limits** and **control limits** are entered. The measured value logging for SPC is started manually or externally. It can be started, continued or deleted. The ND 287 saves up to 1000 measured values in a nonvolatile FIFO memory.

To evaluate the recorded measured values, the ND 287 provides the following functions:

- **Statistical view** of measured values in the FIFO memory
- **Measured value overview** with tabular view of the measured values.
- **Diagram** with graphical display of the last 30 measured values
- **Histogram** in ten classes with **probability density function** and **process capability indexes** c_p and c_{pk} .
- Control chart for **average value \bar{x}** **standard deviation s** and **range r** (difference between maximum and minimum value) of a sample

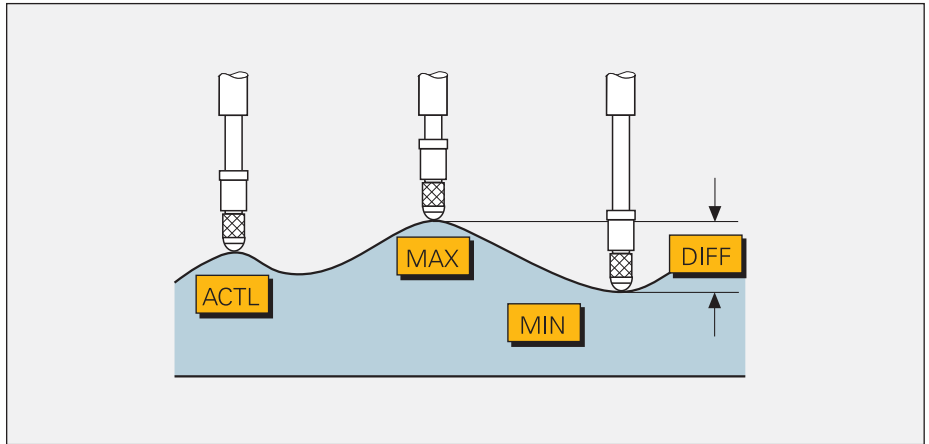

Minimum/maximum value storage

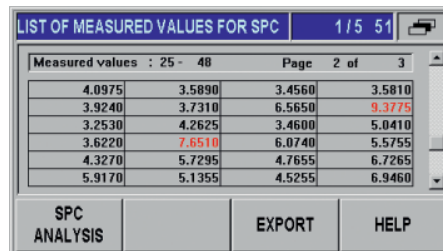
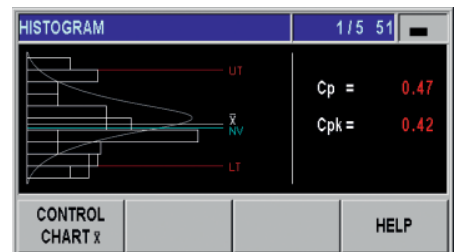
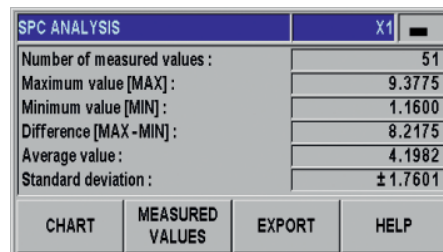
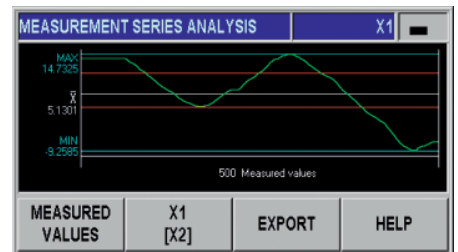
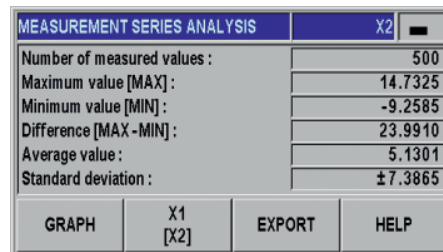

Functions

– Probing functions for datums (ND 780, POSITIP, ND 1200R)

Easy setup with probing functions

A very useful accessory for datum setting is the HEIDENHAIN KT edge finder. Simply move the edge finder toward a side of the workpiece until the stylus deflects. The counter automatically stores the exact position, taking into account the direction of approach and the radius of the stylus. In milling machine mode, the ND 780, ND 1200R and POSITIP digital readouts offer the following probe functions:

- Workpiece edge as reference line
- Workpiece centerline as reference line
- Circle center as datum

For electrically conductive workpieces, these functions are also possible on the ND 780 with an edge finder with contact triggering to ground.

Datum finding with the tool

The probe functions can also be performed with the tool.

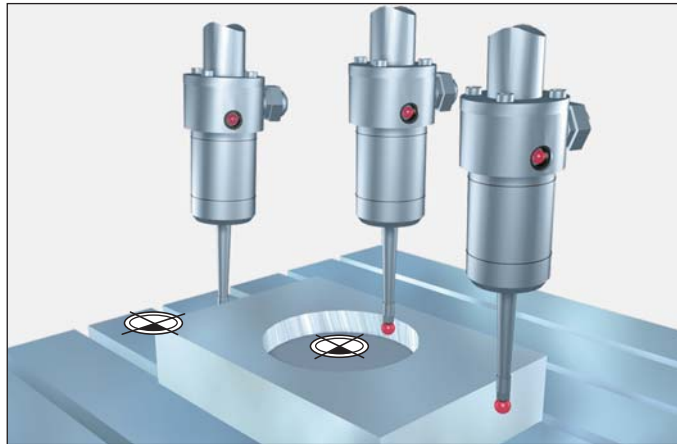

Accessory: KT edge finder

The KT is a triggering edge finder. The cylindrical stylus is spring-mounted in the edge finder housing. The stylus is deflected when it contacts the workpiece, and the edge finder sends a triggering signal over the connecting cable to the ND or the POSITIP.

The KT edge finder allows you to set datums quickly and easily, without leaving marks on the workpiece.

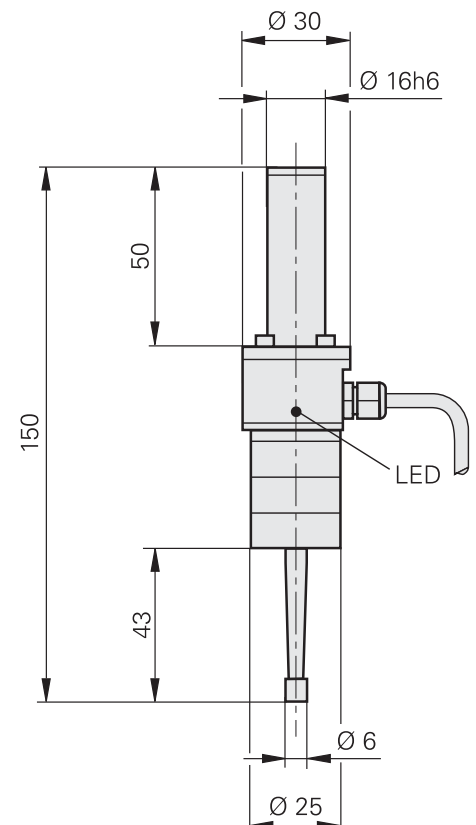

– Tool compensation (series ND 500, ND 780, POSITIP)

Tool compensation for milling machines

The digital readouts of the ND 500, ND 780 and POSITIP series can save tool data, i.e. diameter, and the POSITIP also saves the length and axis of the tool in use. The POSITIP 880 features a tool table for 99 tools, in which the data of pre-set tools or tool data determined on the machine can be stored.

When positioning in distance-to-go mode, the readouts take the tool radius (R+ or R-) in the machining plane into account, and the POSITIP also considers the tool length (ΔL) in the spindle axis.

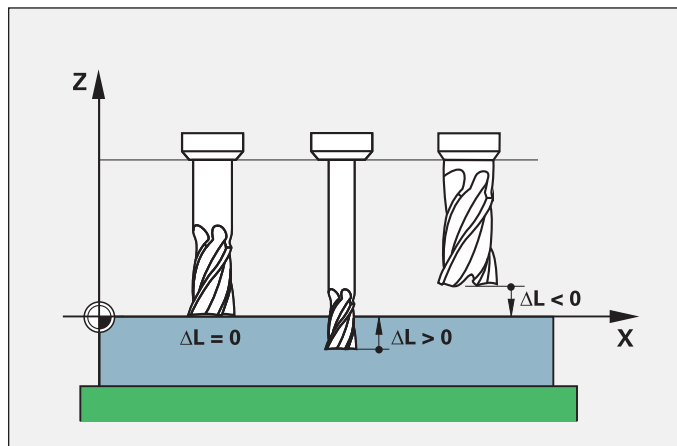
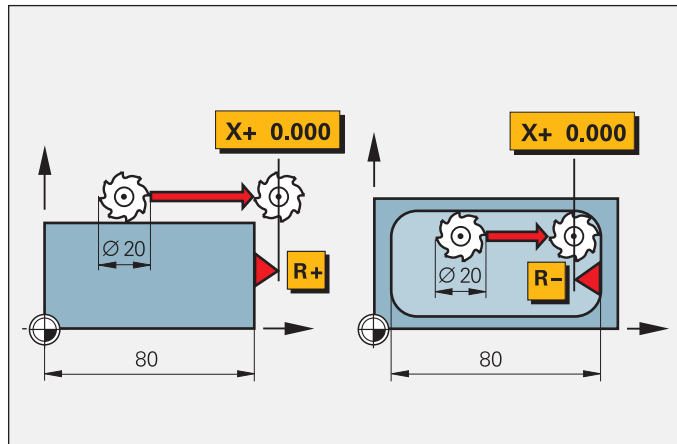

Determining and storing tool compensation values on lathes

With the ND 52x or ND 780 (16 tools) and the POSITIP (99 tools) readouts, you can store the dimensional data for the tools you insert in the turret or quick-change holder:

- Enter the tool position directly when turning the first diameter, or
- “freeze” the current axis position value, retract the tool, measure the turned diameter and then enter that value.

Changing datums

If you change the workpiece or the workpiece datum, you can fix the new datum without having to change the stored tool-offset values. The tool data are automatically referenced to the new datum.

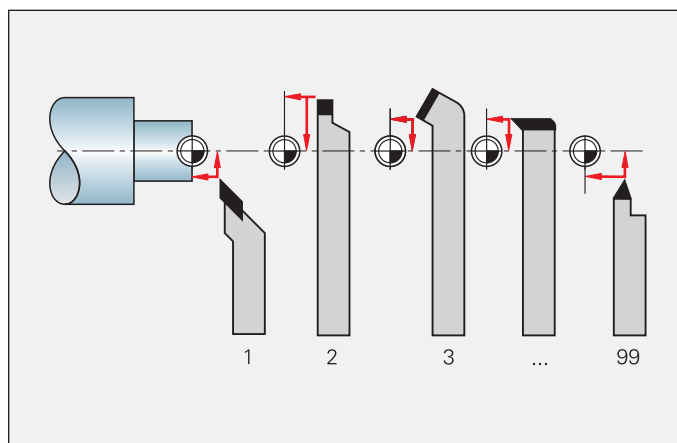

Functions

– Distance-to-go display (all digital readouts)

Distance-to-go display for turning and milling

The distance-to-go display feature simplifies your work considerably: you enter the next nominal position, and the display shows you the distance remaining to the target position. This means, you simply move to the display value zero.

The displays for milling can also compensate the cutter radius. In this way you can directly use the drawing dimensions without having to do any conversions. You no longer have to remember any complicated values.

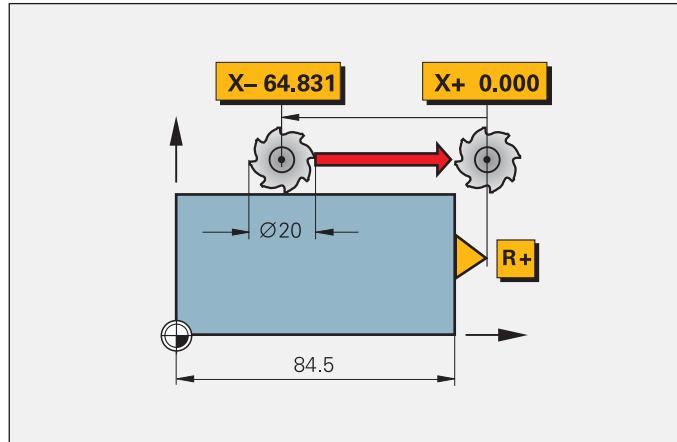

On POSITIP, the distance-to-go display is enhanced by a graphic positioning aid: As you traverse to zero, a square cursor moves into a target fork. If you prefer (for example for turning), the display can show the absolute position value instead of the graphic.

POSITIP's distance-to-go display

With POSITIP, **oversizes** can be taken into consideration when turning. Simply enter the oversize and use the distance-to-go display to traverse to zero.

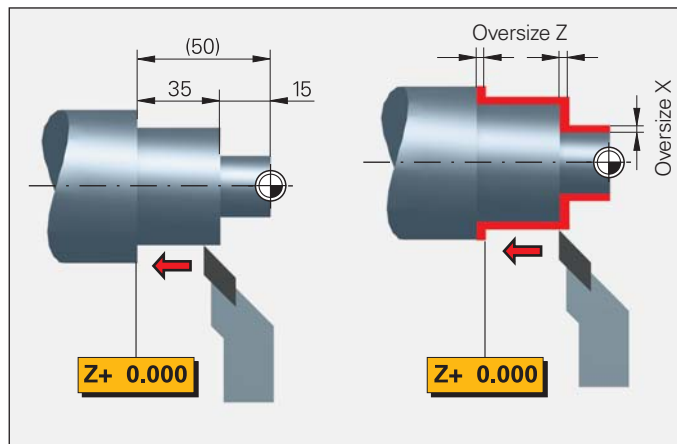

– Hole patterns (series ND 500, ND 780, POSITIP, ND 1200R)

Automatic calculation of bolt hole patterns for milling and drilling

In milling machine mode you can machine **bolt hole circles** (full circle or circle segments) and **linear hole patterns** without having to calculate:

You simply enter the geometric dimensions and the number of holes from the drawing. The display calculates the coordinates of the individual holes in the working plane. You only need to traverse "to zero" and drill. Then the display shows the next position. The **graphic display** is a particularly useful feature: it lets you verify your input of the programmed bolt-hole pattern before machining.

On the **ND 1200R**, the hole positions are displayed as distance to go both for the angular axis and radial axis.

If certain holes have to be machined for a second time, the ND 1200R remembers these positions at a keystroke. After ending the first operation, you can easily jump back to the positions concerned.

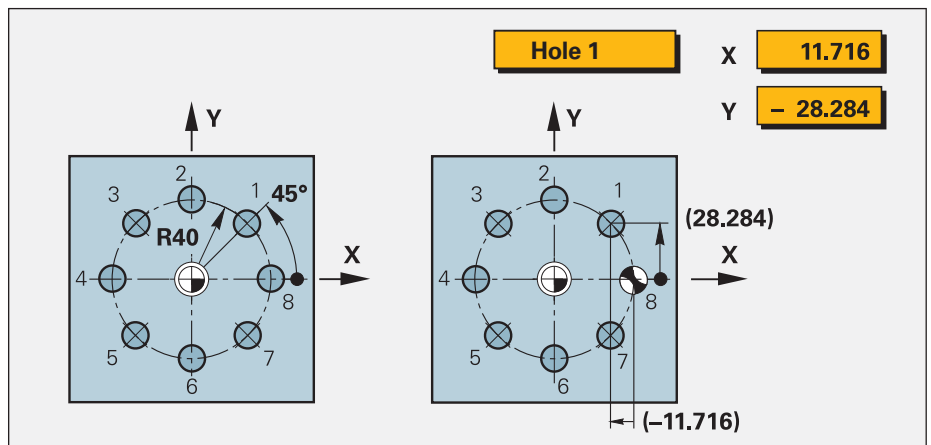

| | |
|------------------------------|--------|
| D:0 T:1 F: 0 0:00 MM | |
| LINEAR PATTERN | |
| TYPE | ARRAY |
| FIRST HOLE | |
| X | 20.000 |
| Y | 15.000 |
| HOLES PER ROW | |
| 4 | |
| ARRAY FRAME | HELP |

Select the pattern type (ARRAY or FRAME).

| | |
|--------------|-------------------------|
| SINGLE CYCLE | |
| 001 | CYCL 1.0 NO. 1 |
| 002 | CYCL 1.2 CX +0.000000 |
| 003 | CYCL 1.3 CY +0.000000 |
| 004 | CYCL 1.4 SHP +0.000000 |
| 005 | CYCL 1.5 START 27.05.00 |
| 006 | CYCL 1.6 DEPTH THRU |
| 007 | CYCL 1.6 DEPTH THRU |

HOLE 1 OF 8 Move to (X = 0.000, Y = 0.000). Drill Z to THRU Press NEXT HOLE.

VIEW: (PGM/GRAPH) PREVIOUS HOLE NEXT HOLE END



Functions

- Contour monitoring (series ND 500, POSITIP)
- Rectangular pockets (POSITIP)

ND 500 series, POSITIP: Contour monitoring for overseeing manual 2-D operations

Particularly for 2-D milling and turning, the contour monitoring function shows you whether you are moving the tool near to the defined contour. The **POSITIP** supports it in an especially compatible way: it shows whether you are still within the tolerance limits that you have defined. The magnify function makes this possible even for relatively narrow tolerances while a second window provides you with an overall view of the workpiece.

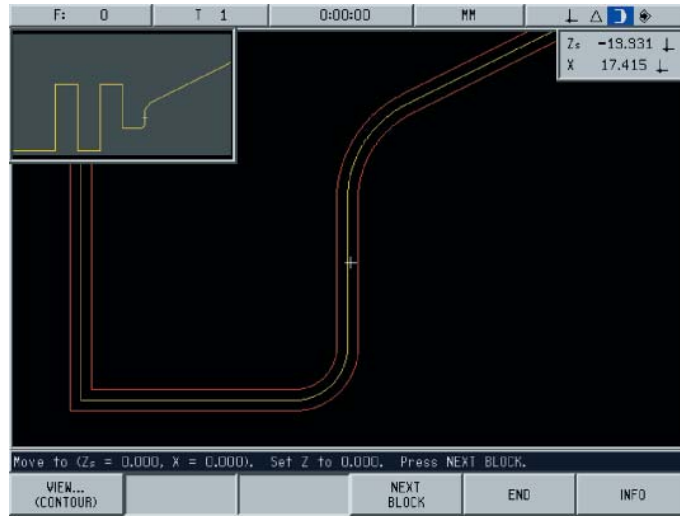

POSITIP: Milling and roughing-out rectangular pockets

The POSITIP aids you in milling and roughing out rectangular pockets. The digital readout calculates from your input the required positioning steps, and you simply position to the zero position value.

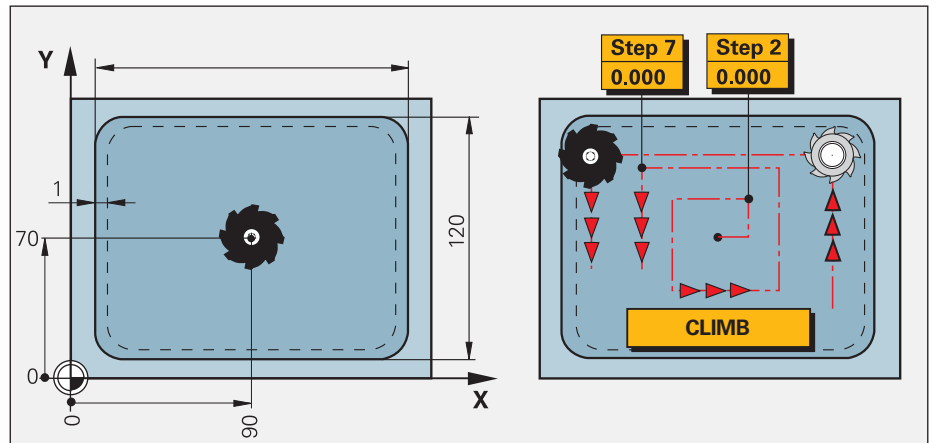

– Help when working with lathes (series ND 500, ND 780, POSITIP)

Radius/diameter display

In the lathe mode you can see the positions of the transverse axis in either radius or diameter values. You can switch at a keystroke.

Sum display of longitudinal axes

In lathe mode, the positions of the saddle and the top slide are displayed either separately or as the sum of both values.

- If you select **separate displays**, the position values are referenced to the datum for each individual axis. If only the saddle is moved, the displayed value for the top-slide axis remains unchanged.
- If **sum display** is selected, the counter adds both values while taking the algebraic sign into account. You can now read the absolute position of the tool in relation to the workpiece datum—without having to calculate!

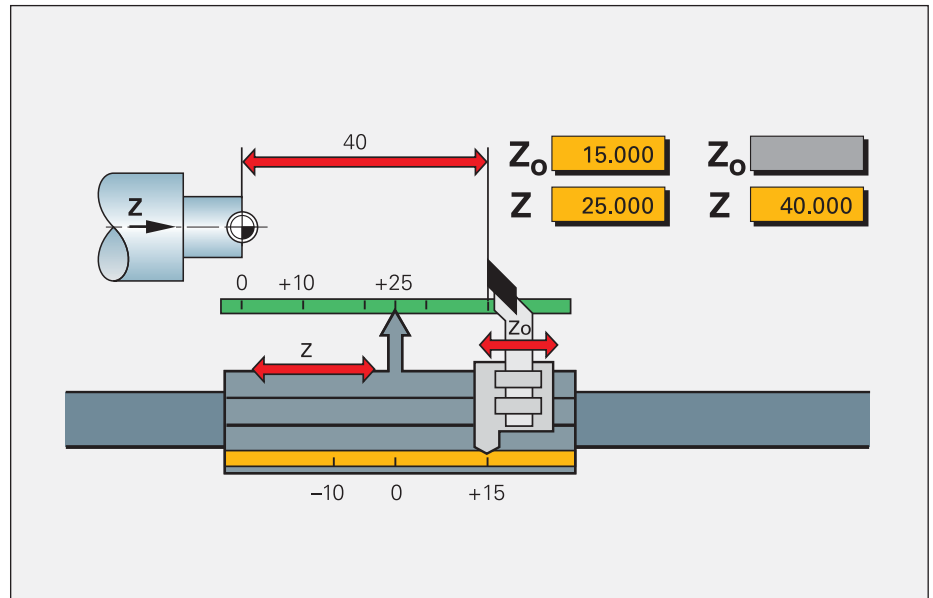

Taper turning made easy

If taper dimensions do not include the angle, the integrated taper calculator will help you with the calculation. Simply enter the taper ratio or the two diameters and the length. The correct angle for the top slide will be displayed immediately.

Multipass cycle

The POSITIP digital readout features a cycle for turning a shoulder in several passes. The distance remaining to the target position is shown both in the longitudinal and tool axes. You decide on the best infeed increment.

Constant surface speed

Particularly in taper turning or parting, the surface speed usually changes along with the diameter. But a constant surface speed is better for optimum machining results and long tool life. In conjunction with the output module IOB 49, the ND 780 digital readout therefore makes it possible to control workpiece rotation to ensure a constant surface cutting speed in spite of a changing workpiece diameter.

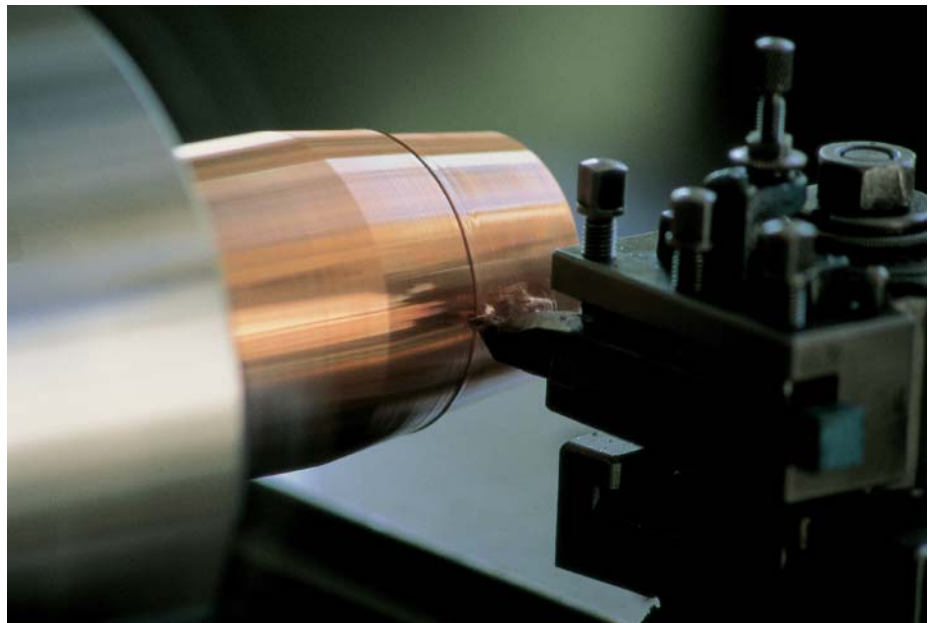

Functions

– Programming of machining steps (POSITIP, ND 1200 R)

The programming functions of POSITIP and ND 1200 R allow you to save repetitive machining steps as a program. Thus for example you can save all of the machining steps required as a program for a workpiece in a small-batch. In the Programming mode of operation, the distance-to-go display will guide you step-by-step to the programmed positions.

You can create programs by either keying them in step by step or generating them through actual position capture (teach-in programming).

POSITIP also allows you to generate program-section repeats and subprograms. If you are machining point patterns, you can program incremental positioning steps and then repeat them as often as necessary (program-section repeat). If you need to run the same program sequence at separate locations on the workpiece, you can write a subprogram and call it as needed. This saves you work at the keyboard and reduces inputting errors. Fixed cycles such as Bolt Hole Circle, Linear Hole Pattern or Rectangular Pocket (boring, milling) or Multipass (turning) keep your programs short and save you programming time. In the course of your work, the readout presents each nominal position in the proper sequence. You need only move from one position to the next.

With the **ND 1200 R** you can also save the hole diameter for each position; when you run the program later, **RADIAL-DRILL** displays the respective hole diameters for each position.

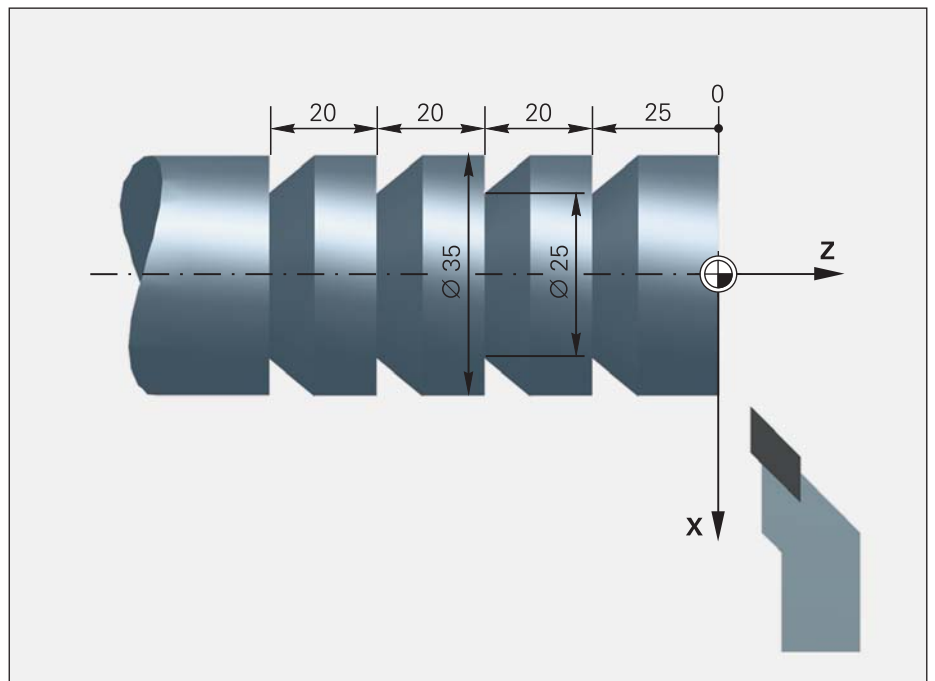
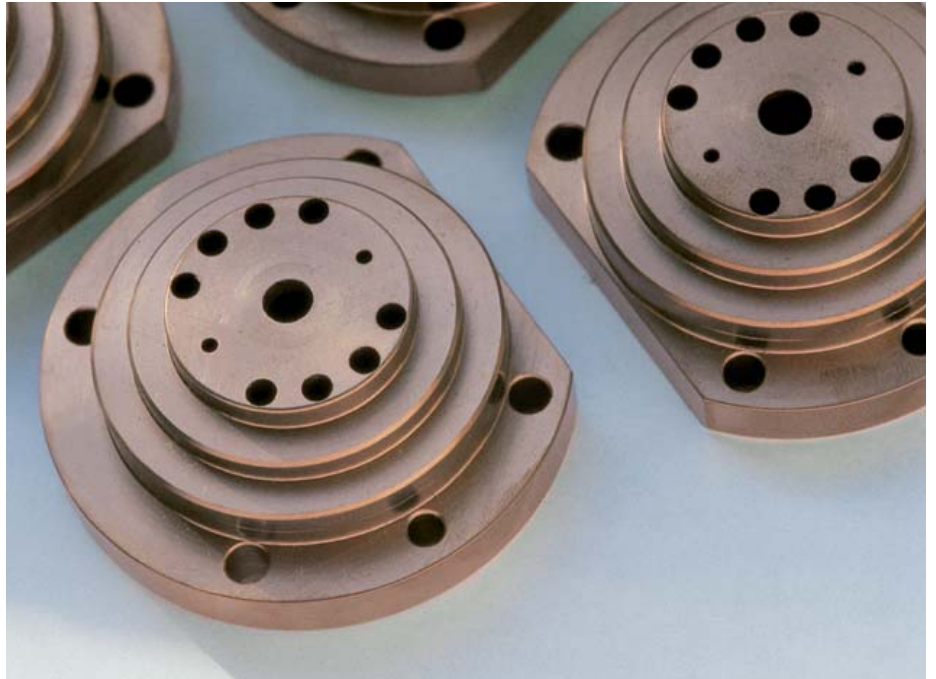

Example of a POSITIP program:
Turning several recesses on the same workpiece

```
000 BEGIN PGM 40 MM
001 X+80.000
002 Z+20.000
003 X+40.000
004 Z-5.000
005 LBL #8
006 IZ-20.000
007 X+25.000
008 X+40.000
009 CYCL 7.0 RPTLBL 8 3/3
010 CYCL 7.1 OUTZ +0.000
011 CYCL 7.2 OUTX +0.000
012 X+80.000
013 END PGM 40 MM
```

– For fast and conventional radial drills (ND 1200 R)

The special functions for **standard radial drills** (with moving drill head mounted laterally) and the **fast radial drills** (with drill head at end of radially moving arm) are integrated in the ND 1200 R RADIAL-DRILL readouts.

Coordinate transformation

You can switch between display in polar coordinates (radius R and angle A) and Cartesian coordinates (X, Y) at any time with a simple keystroke—even during positioning. You can also switch as desired between absolute or incremental dimension display.

XY drilling coordinates

For positioning, the ND 1200 R automatically converts position values from polar coordinates to Cartesian coordinates. You enter the drawing's dimensions—absolute or incremental—directly as XY coordinates. RADIAL DRILL calculates the path from the momentary position to the target position and shows you this remaining distance as separate values of the radial and angular axes, i.e. in machine coordinates. You position the tool head simply by moving to the display value zero: first you position the head to the radius display value zero and then you swing the arm until the angular display (A) is at zero.

It is advisable during positioning, however, that at least one of the axes can be clamped separately from the other.

Drill diameter

For every position you can save a drill diameter that is displayed when the position is next called.

| Target Entry | | | |
|--------------|---|--------|-------|
| 1 | X | 39,000 | INC 1 |
| | Y | 28,000 | INC 1 |
| | D | 0,000 | |
| DRO | | | |
| | | INC | Hole |

Entry in Cartesian coordinates

| Dist. from Trgt | | | | MM | INC | P | --- |
|-----------------|------|--------|-----|-------------|---------|-----|-----|
| | R | 74,620 | | | | | |
| | A | 38°213 | | | | | |
| DRO | | | | X | 39,000 | Abs | ✓ |
| | | | | Y | -28,000 | Abs | |
| | | | | Drill Size: | 0,000 | | |
| Goto | Edit | INC | R/A | Menu | | | |

Display of distance to go in polar coordinates

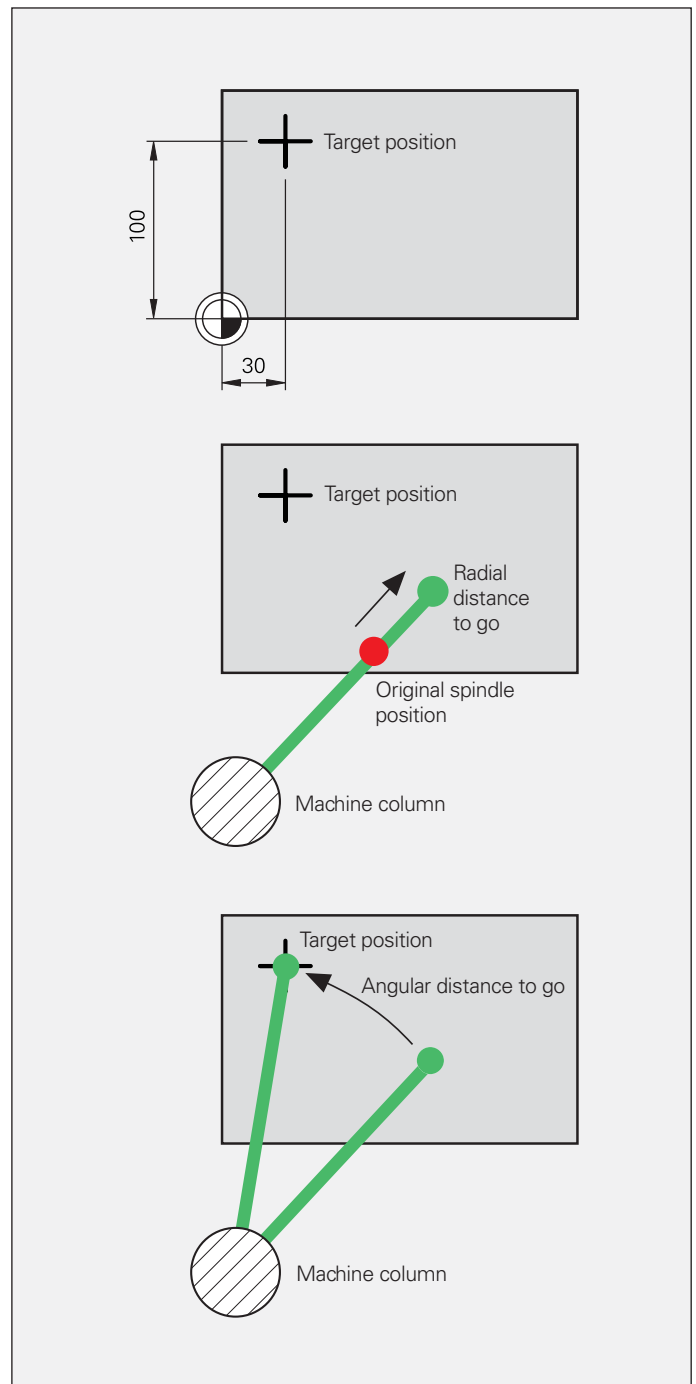

ND 200 series

– Universal digital readouts for one axis

The ND 200 series offers digital readouts for one axis. Due to their performance range, they are predestined for measuring and inspection stations, but they are also suited to simple positioning tasks such as infeed for a circular saw, the stroke of press travel, or the position of an additional rotary table on a machine tool. The switching inputs and outputs of the ND 287 permit operation also in simple automated environments.

Description

The ND 200 series features a sturdy aluminum die-cast housing. The splash-proof full-travel keyboard is built for the workshop. A large graphic TFT monitor displays the measured values, the status and the soft-key row.

Functions

The standard **ND 280** readout provides the basic functions for simple measuring tasks. The **ND 287** features numerous functions for measuring and statistical evaluation of measured values such as sorting and tolerance check mode, minimum/maximum value storage, and measurement series storage. These data make it possible to calculate mean values and standard deviations and display them in histograms or control charts. With its modular design, the ND 287 permits connection of a second encoder for sum/difference measurement or of an analog sensor, for example for temperature compensation.

Data interfaces

The ND 28x have serial interfaces for measured value transfer to a PC or printer, for input/output of parameters and compensation value lists, and for diagnostics:

- USB (UART)
- RS-232-C/V.24
- Ethernet 100BaseT (option, only with ND 287)



ND 287

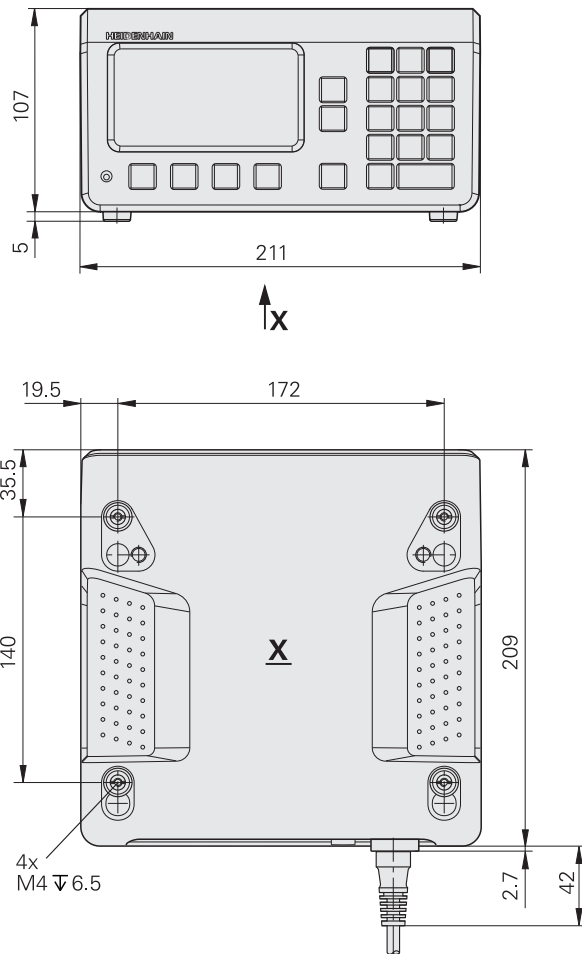

mm

 Tolerancing ISO 8015
 ISO 2768 - m H
 < 6 mm: ±0.2 mm

| | ND 280 | ND 287 |
|---|---|--|
| Axes | 1 | 1; option: second input through encoder module |
| Encoder inputs | $\sim 1 V_{PP}$ $\sim 11 \mu A_{PP}$ or EnDat ¹⁾ : D-sub female 15-pin (automatic interface recognition) | |
| Input frequency | $\sim 1 V_{PP}$: ≤ 500 kHz; $11 \mu A_{PP}$: ≤ 100 kHz | |
| Subdivision factor | 4096-fold | |
| Display step ²⁾ | Adjustable, max. 9 decades <i>Linear axis:</i> 0.5 to 0.002 μm <i>Angular axis:</i> 0.5° to 0.00001° or 00°00'00.1" | |
| Analog input | – | Option: ± 10 V through analog module |
| Resolution | – | 5 mV |
| Display | Monochrome TFT screen | Color TFT screen |
| | Position values, dialogs and input, graphic functions and soft keys | |
| Status display | Operating mode, REF, datum, scaling factor, compensation, stopwatch, unit of measure, soft-key level | |
| Functions | <ul style="list-style-type: none"> • REF reference-mark evaluation for distance-coded or single reference marks • 2 datums • Distance-to-go mode • Integrated help and diagnostics • Remote operation via serial interface | |
| | – | <ul style="list-style-type: none"> • Sorting and tolerance checking • Measurement series with min./max. value storage • Saving measured values (max. 10000) • Functions for Statistical Process Control (SPC) • Graphic depiction of distribution/histogram • Sum/difference display (with 2nd encoder module) • Thermal compensation (with analog module) |
| Axis-error compensation | <i>Linear axis:</i> Linear and multipoint over up to 200 points <i>Angle axis:</i> Multipoint linear with 180 compensation points (every 2°) | |
| Data interface | <ul style="list-style-type: none"> • RS-232-C/V.24 • USB (UART) port type B | |
| | – | Option: Ethernet 100BaseT, via Ethernet module |
| Switching outputs For tasks in automation | – | <ul style="list-style-type: none"> • Zero crossover • Trigger points 1 and 2 • Sorting signals "<" and ">" • Errors |
| Switching inputs For tasks in automation | – | <ul style="list-style-type: none"> • Zero reset, preset • Cross over reference point and ignore reference signals • Measured value output or display freeze (pulse or contact) • Start measurement series • Minimum/maximum/difference value • Gating of the two encoder inputs • Sum or difference display • Display measured value 1 or measured value 2 |
| Power connection | 100 to 240 V AC (–10 % to +15 %), 48 Hz to 62 Hz; 30 W | |
| Operating temperature | 0 °C to 45 °C (storage temperature –20 °C to 70 °C) | |
| Protection EN 60529 | IP 40, front panel IP 54 | |
| Weight | Approx. 2.5 kg | |

¹⁾ Purely serial, no evaluation of the incremental signals

²⁾ Depends on the signal period of the connected encoder (display step \approx signal period/4096)

ND 500 series

– Simple position display unit for two and three axes

The position displays of the ND 500 series are suited for use on manually operated milling, drilling, boring machines and lathes with two or three axes. Due to the TTL encoder input, primarily the LS 328 and LS 628 linear encoders with a measuring step of 5 µm are used.

Description

With its sturdy housing and splash-proof membrane keyboard, the ND 500 is built for the workshop. The ND 500 series shows display position values, the soft-key row and other useful information on a monochrome graphic screen.

Functions

The most important functions are available quickly and directly via function keys. Soft keys with clear information in the local language enable you to make entries that fit your momentary situation.

The **distance-to-go display** facilitates positioning. You approach the next position quickly and reliably by simply positioning until the display reads "zero." The functions for each application are easily activated by parameter input. Special functions are available for producing **hole patterns** (linear patterns and circular patterns).

You can easily switch between radius and diameter display when the position display is configured for turning. On lathes with a separate top slide, the **sum display** feature of the ND 523 allows you to display the saddle and top slides together or separately. Setting datums on a lathe part is particularly easy with the **freeze tool position** function and subsequent retracting.

Data interfaces

A USB interface enables the digital readout to transfer measured values and import or export parameters and tables.



ND 523

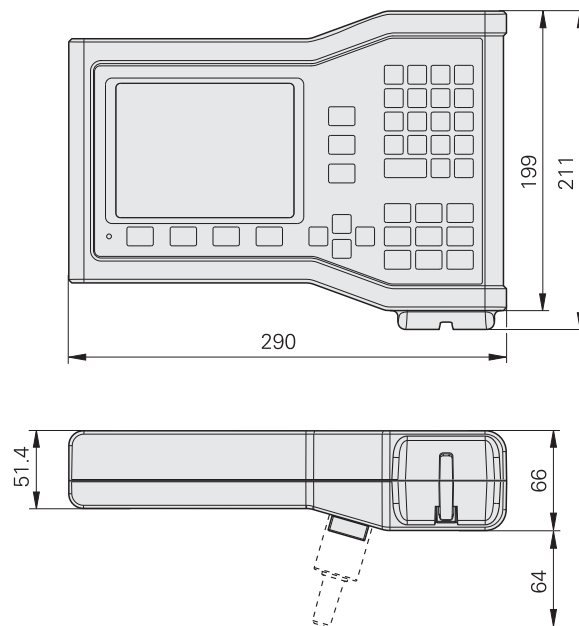

mm

 Tolerancing ISO 8015
 ISO 2768 - m H
 < 6 mm: ±0.2 mm

| | ND 522 | ND 523 |
|----------------------------------|--|---------------------------------------|
| Axes | 2 axes from A to Z | 3 axes from A to Z and Z _S |
| Encoder inputs | 2 x □□TTL; D-sub female 9-pin | 3 x □□TTL; D-sub female 9-pin |
| Input frequency | ≤ 100 kHz | |
| Signal period | 2 μm, 4 μm, 10 μm, 20 μm, 40 μm, 100 μm, 10240 μm, 12800 μm | |
| Line count | Any | |
| Evaluation | 1/2/4-fold | |
| Display step¹⁾ | <i>Linear axis:</i> 1 mm to 0.0001 mm; 0.005 with LS 328/LS 628 <i>Angular axis:</i> 1° to 0.0001° (00° 00' 01") | |
| Display | Monochrome flat screen for position values, dialog and input displays, graphic functions and graphic positioning support | |
| Status display | Operating mode, REF, reference-point number, tool number, inch, scale, feed-rate display, stopwatch | |
| For milling/drilling/boring | Tool compensation R+, R- | |
| For turning | Radius/diameter display Separate or sum display for Z and Z _O | |
| Functions | <ul style="list-style-type: none"> • 10 datums • 16 tools • REF reference mark evaluation for distance-coded and single reference marks • Distance-to-go display with nominal position input in absolute or incremental values • Contour monitoring • Scaling factor • mm/inch switching • HELP: On-screen operating instructions • INFO: Stopwatch, pocket calculator, cutting data calculator (for milling), taper calculator (for turning) | |
| For milling/drilling/boring | <ul style="list-style-type: none"> • Calculation of positions for hole patterns (circular patterns as well as linear patterns) • Tool radius compensation | |
| For turning | <ul style="list-style-type: none"> • Freezing the tool position for back-off | |
| Error compensation | <i>Axis error:</i> Linear and multipoint over up to 200 points <i>Backlash compensation:</i> For length measurement via ball screw and rotary encoder | |
| Data interface | USB type B connector; 115200 baud <ul style="list-style-type: none"> • For output of measured values and parameters • For input of parameters, remote control of keys and commands | |
| Accessories | Base, mounting arm | |
| Power connection | 100 to 240 V AC (-15 % to +10 %), 48 Hz to 62 Hz; 25 W | |
| Operating temperature | 0 °C to 45 °C (storage temperature -20 °C to 70 °C) | |
| Protection EN 60529 | IP 40, front panel IP 54 | |
| Weight | Approx. 2.6 kg | |

¹⁾ Depends on the signal period or line count of the connected encoder

ND 780 series

– Adaptable readout for up to three axes

The ND 780 digital readout is especially suited for use on milling, drilling and boring machines and lathes with up to three axes. A separate I/O unit provides switching input/outputs for simple tasks in automation.

Design

The ND 780 digital readout is designed as a sturdy upright unit with splash-proof full-travel keypad for use in a workshop. It is equipped with a monochrome flat screen for position values, dialog and input displays, graphic functions and graphic positioning support.

Functions

The **ND 780** readout is characterized by its plain language dialog guidance. The **distance-to-go display** facilitates positioning. You approach the next position quickly and reliably by simply moving until the display reads "zero." The functions for each application are easily activated by parameter input. Special functions are available for producing **hole patterns** (linear patterns and circular patterns). Datums can be determined quickly and accurately with an edge finder. The ND 780 readout supports you with special **probing functions**.

You can easily switch between radius and diameter display when the position display is configured for turning. The readout also offers support for lathes with separate top slide: The **sum display feature** allows you to display the saddle and top slides together or separately. To set a datum, touch the workpiece and **freeze the tool position**. Then retract and measure the workpiece.

Data interfaces

The ND 780 has an RS-232-C/V.24 serial interface for measured value transfer to a PC or printer, for input/output of parameters and compensation value lists, and for diagnostics.

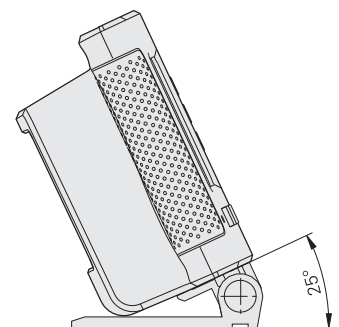
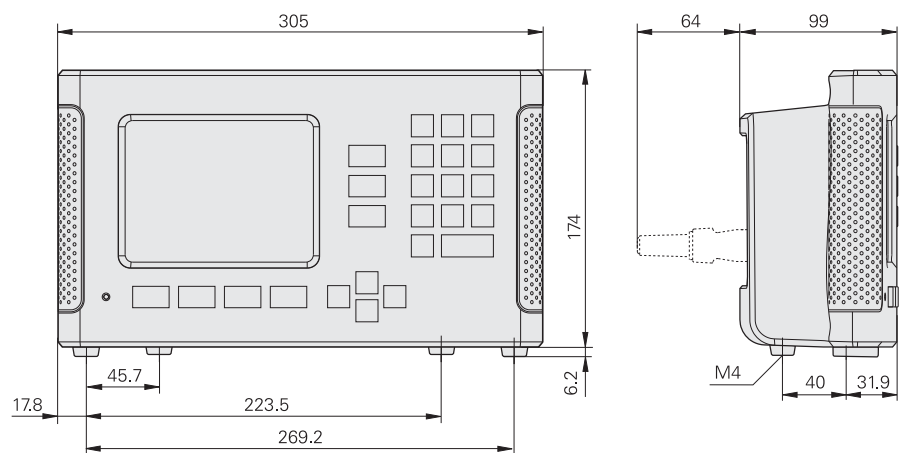

mm

 Tolerancing ISO 8015
 ISO 2768 - m H
 < 6 mm: ±0.2 mm

| ND 780 | |
|----------------------------------|--|
| Axes | Up to 3 axes from A to Z and Z ₀ , Z _S |
| Encoder inputs | 3 x \sim 1 V _{PP} or \sim 11 μ A _{PP} ; D-sub female 15-pin (automatic interface recognition) |
| Input frequency | \leq 100 kHz |
| Signal period | 2 μ m, 4 μ m, 10 μ m, 20 μ m, 40 μ m, 100 μ m, 10240 μ m, 12800 μ m |
| Line count | Any |
| Subdivision factor | Max. 1024-fold |
| Display step¹⁾ | <i>Linear axis:</i> 1 mm to 0.0001 mm <i>Angular axis:</i> 1° to 0.0001° (00° 00' 01") |
| Display | Monochrome flat screen for position values, dialog and input displays, graphic functions and graphic positioning support |
| Status display | Operating mode, REF, reference-point number, tool number, inch, scale, feed-rate display, stopwatch |
| For milling/drilling/boring | Tool compensation R+, R- |
| For turning | Radius/diameter display Separate or sum display for Z and Z ₀ |
| Functions | <ul style="list-style-type: none"> • 10 datums • 16 tools • REF reference mark evaluation for distance-coded and single reference marks • Distance-to-go display with nominal position input in absolute or incremental values • Scaling factor • mm/inch switching • HELP: On-screen operating instructions • INFO: Stopwatch, pocket calculator, cutting data calculator (for milling), taper calculator (for turning) |
| For milling/drilling/boring | <ul style="list-style-type: none"> • Calculation of positions for hole patterns (circular patterns as well as linear patterns) • Tool radius compensation • Probing function for datum acquisition with the KT edge finder: "Edge," "Centerline" and "Circle center" |
| For turning | <ul style="list-style-type: none"> • Freezing the tool position for back-off • Setup functions for datum setting with the tool |
| Error compensation | <i>Axis error:</i> Linear and multipoint over up to 200 points <i>Backlash compensation:</i> For length measurement via ball screw and rotary encoder |
| Data interface | RS-232-C/V.24 300 to 115200 baud <ul style="list-style-type: none"> • For output of measured values and parameters • For input of parameters, remote control of keys and commands |
| Switching I/O | <ul style="list-style-type: none"> • Two inputs (pulse or contact) for measured value output • 1 input for KT edge finder • 1 input for edge finder with contact triggering • Further input/outputs over the IOB 49 input/output unit |
| Accessories | KT edge finder (for milling) tilting base, handle, tilt/swivel mount, pivot arm |
| Power connection | 100 to 240 V AC (-15 % to +10 %), 48 Hz to 62 Hz; 30 W |
| Operating temperature | 0 °C to 45 °C (storage temperature -20 °C to 70 °C) |
| Protection EN 60529 | IP 40, front panel IP 54 |
| Weight | Approx. 2.6 kg |

¹⁾ Depends on the signal period or line count of the connected encoder

POSITIP 880

– The programmable readout for up to six axes

The POSITIP 880 is a versatile display unit designed primarily for milling machines, drilling and boring machines and lathes with up to six axes. A separate I/O unit provides switching input/outputs for simple tasks in automation.

Design

The POSITIP 880 is designed as a sturdy upright unit with splash-proof full-travel keypad for use in the workshop. It supports all operations with straightforward interactive menus on its large, easy-to-read color flat screen.

Functions

The POSITIP provides advanced features beyond those offered by the ND 780 digital readout. The POSITIP supports any axis combination and helps you at 2-D machining operations with its graphic contour monitoring and magnify function. In the milling mode, it supports you in machining and clearing out rectangular pockets while it takes allowances into account during turning.

The programming capabilities of POSITIP make it ideal for small-batch production on conventional machine tools: you can store up to 999 program blocks per program in its memory. Programs are created by either keying them in step by step or generating them through actual position capture (teach-in programming). With the sub-programming capability, you can enter repetitive machining sequences on the same workpiece once only. Fixed cycles keep your programs short and save you programming time.

Data interfaces

The POSITIP 880 has an RS-232-C/V.24 serial interface for measured value transfer to a PC or printer, for input/output of parameters and compensation value lists, and for diagnostics. A parallel Centronics interface is also provided for pure measured value output.

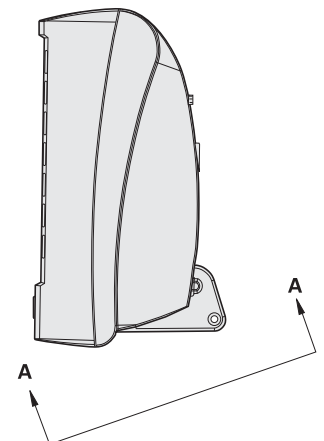
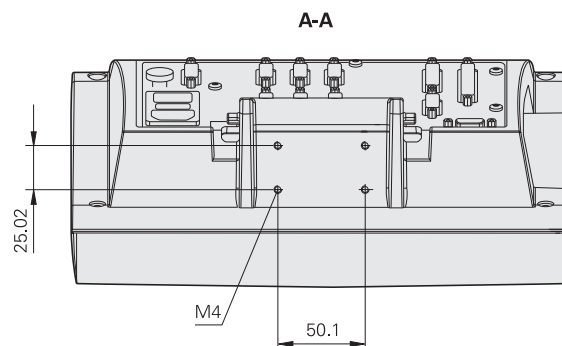
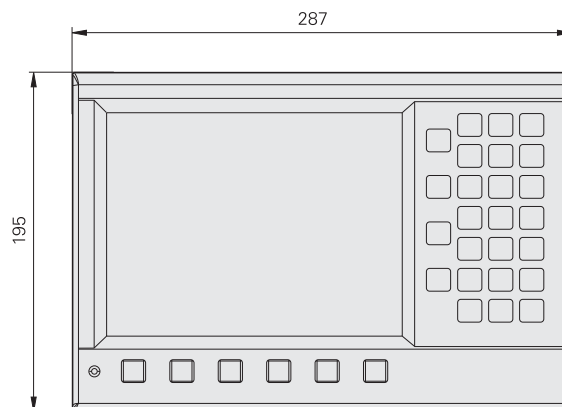

mm

 Tolerancing ISO 8015
 ISO 2768 - m H
 < 6 mm: ±0.2 mm

| | | POSITIP 880 |
|----------------------------------|-------------------------------------|---|
| Axes | | Up to 6 axes from A to Z and Z _O , Z _S |
| Encoder inputs | | 6 x $\sim 1 V_{PP} \sim 11 \mu A_{PP}$ or EnDat 2.1; D-sub female 15-pin (automatic interface recognition) |
| Input frequency | | ≤ 100 kHz |
| Signal period | | 0.128 μm , 2 μm , 4 μm , 10 μm , 20 μm , 40 μm , 100 μm , 10240 μm , 12800 μm |
| Line count | | Any |
| Subdivision factor | | Max. 1024-fold |
| Display step¹⁾ | | <i>Linear axis:</i> 1 mm to 0.005 μm <i>Angular axis:</i> 0.01° to 0.0001° (00° 00' 01") |
| Display | | Color flat screen for position values, dialog and input displays, graphic functions, graphic positioning support and contour monitoring |
| Status display | | Operating mode, REF, reference-point number, tool number, inch, scale, feed-rate display, stopwatch |
| For milling/drilling/boring | | Tool compensation R+, R- |
| For turning | | Radius/diameter display; separate or sum display for Z and Z _O |
| Functions | | <ul style="list-style-type: none"> • REF reference-mark evaluation for distance-coded or single reference marks • Distance-to-go mode, nominal position input (absolute or incremental) • Scaling factor • Contour monitoring with magnify function • Any axis combinations • HELP: On-screen operating instructions • INFO: Stopwatch, pocket calculator, cutting data calculator (for milling), taper calculator (for turning) |
| For milling/drilling/boring | | <ul style="list-style-type: none"> • 99 datums and 99 tools • Calculation of positions for hole patterns (circular patterns as well as linear patterns) • Tool radius compensation • Probing function for datum acquisition with the KT edge finder: "Edge," "Centerline" and "Circle center" • Positioning aids for milling and the roughing out of a rectangle pocket |
| For turning | | <ul style="list-style-type: none"> • 1 datum, 99 tools • Freezing tool position for back-off • Oversize allowances |
| Programming | | Up to 999 program blocks per program; sub programming capability with turning and mirroring; teach-in programming |
| Cycles | For milling/drilling For turning | Line segments, circular arcs, chamfers, circular and linear hole patterns, rectangular pockets Line segments, circular arcs, chamfers, multipass |
| Error compensation | | Linear and multipoint, up to 128 measuring points |
| Interfaces | Serial Parallel | RS-232-C/V.24 300 to 115200 baud <ul style="list-style-type: none"> • For output of programs, measured values and parameters • For loading of programs and parameters Centronics for output of measured values |
| Switching I/O | | <ul style="list-style-type: none"> • Via IOB 89 external input/output unit • 1 input for KT edge finder |
| Accessories | | KT edge finder (milling) tilting base, tilt/swivel mount, pivot arm |
| Power connection | | 100 to 240 V AC (-5 % to +10 %), 48 Hz to 62 Hz; 35 W |
| Operating temperature | | 0 °C to 45 °C (storage temperature -20 °C to 70 °C) |
| Protection EN 60529 | | IP 40, front panel IP 54 |
| Weight | | Approx. 3.2 kg |

¹⁾ Depends on the signal period or line count of the connected encoder

ND 1200R RADIAL-DRILL digital readout

Digital readouts for conventional and fast radial drilling machines

The ND 1200R RADIAL DRILL digital readout is an easily operated, powerful readout for conventional and fast radial drilling machines. Machine movement is measured by a linear encoder on the radial arm and a rotary encoder or a friction-wheel system on the column. An additional encoder on the sleeve can also be used to measure and display the drilling depth.

Design

The ND 1200R RADIAL-DRILL digital readout features a sturdy housing of die-cast aluminum and a splash-proof full-travel keyboard. The monochrome flat-panel graphic display shows position values, plain language dialog and prompts as well as graphic functions.

Functions

With the ND 1200R digital readout you can switch at any time between display in **polar coordinates** (radius R, angle α) and **Cartesian coordinates** (X, Y). With the aid of the **probing functions** you'll find the workpiece datum and orientation faster. One essential working aid is the function for positioning with the **distance-to-go display**: You type in the nominal position—i.e. the drilling coordinates—as X, Y values; the RADIAL-DRILL digital readout shows you the distance remaining to the target position as separate values for the angular and radial axes, which are therefore the machine coordinates. The ND 1200R automatically calculates the positions when machining **hole patterns** such as bolt-hole circles (full circle or circle segment) and linear hole patterns, matrices or frames. The **programming function** of the ND 1200R supports you when machining recurring workpieces and machining patterns.

Interfaces

The RS-232-C/V.24 and USB serial interfaces serve for saving programs and updating software.

Equipping a radial drill

The angular position of the radial arm is usually measured with a rotary encoder and friction wheel system or—for higher accuracy requirements—with an ROD angle encoder or rotary encoder. The drill head position and, if required, the spindle stroke are measured with LS linear encoders. The KT edge finder serves for an exact calibration of the machine and, if desired, to set up the workpiece.

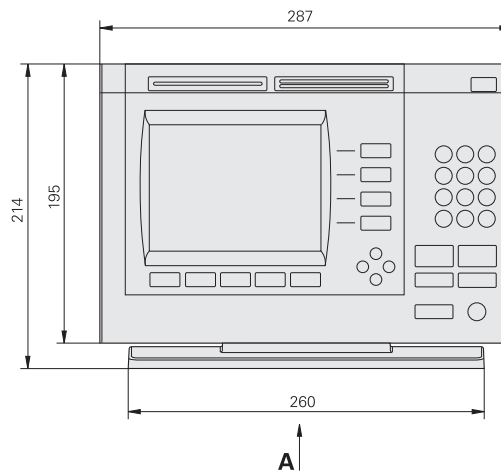
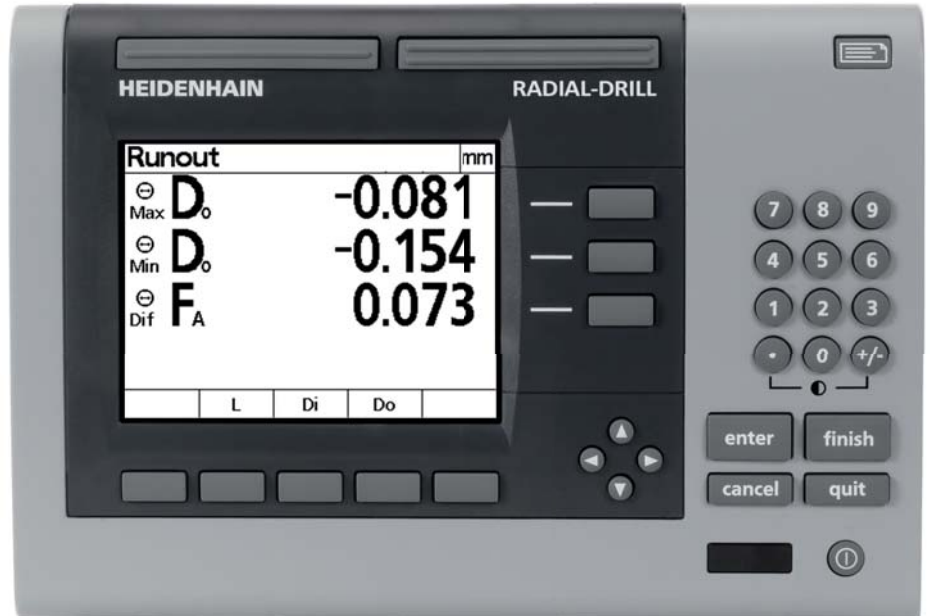

ND 1200R with tilting base

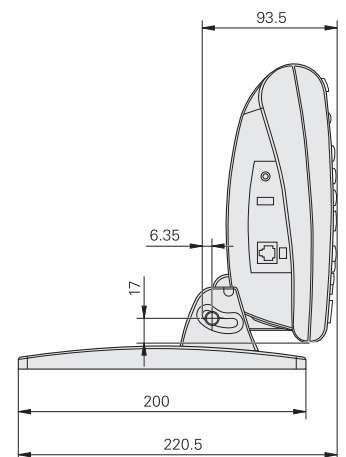

mm

 Tolerancing ISO 8015
 ISO 2768 - m H
 < 6 mm: ±0.2 mm

| | ND 1202R | ND 1203R |
|-----------------------------------|---|---------------|
| Axes | 2 from A to Z | 3 from A to Z |
| Encoder inputs* | □□ TTL (D-sub female 9-pin) or \sim 1 V _{PP} (D-sub female 15 pin) | |
| Input frequency | ≤ 200 kHz | |
| Signal period | Any | |
| Line count | Any | |
| Subdivision factor | □□ TTL: Max. 4-fold \sim 1 V _{PP} : Max. 40-fold | |
| Display step ¹⁾ | Adjustable, max. 7 digits | |
| Display | 5.7" monochrome flat-panel display for position values, dialogs and inputs, and soft keys | |
| Functions | <ul style="list-style-type: none"> • Conversion of Cartesian coordinates (X,Y) to polar coordinates (R,A) • XY/RA switch-over • Alignment function • REF reference-mark evaluation for distance-coded or single reference marks • Distance-to-go display in machine coordinates R and A • mm/inch switching • Absolute-incremental display • Calculation of positions for hole patterns (circular patterns as well as linear patterns) • Probing functions for workpiece orientation and reference-point acquisition with KT edge finder: "Edge," "Centerline" and "Circle center" | |
| Programming | Hole patterns with a total of 999 hole positions | |
| Cycles | Hole patterns (circular and linear patterns) with max. 100 positions | |
| Error compensation | Linear axis-error compensation as part of calibration | |
| Data interface | <ul style="list-style-type: none"> • RS-232-C/V.24; 300 to 115200 baud • USB type A | |
| Switching inputs | <ul style="list-style-type: none"> • Zero reset, measured value output (e.g. by foot switch) • Edge finder (through universal touch probe interface) | |
| Accessories | Mounting arms, KT-130 edge finder, foot switch | |
| Power connection | 100 V to 240 V AC (-15 % to +10 %), 47 Hz to 63 Hz; 30 W | |
| Operating temperature | 0 °C to 45 °C (storage temperature -20 °C to 70 °C) | |
| Protection EN 60529 | IP 40 | |
| Mounting* | Tilting base or mounting base | |
| Weight | Approx. 1.6 kg | |

* Please select when ordering

¹⁾ Depends on the signal period of the connected encoder as well as the subdivision factor

Mounting

– ND 200 and ND 500 series

ND 200 series

The ND 200 series digital readouts were conceived as bench-top units. They can easily be stacked. Recesses on the top prevent the stacked units from moving out of place.

You can secure the ND 28x from below by using M4 screws on a base plate.

Two ND 28x readouts fit next to each other in a 19" housing. A mounting adapter is available as an accessory for mounting in a 19" housing.

Accessories:

Mounting adapter for 19" housing
ID 654020-01

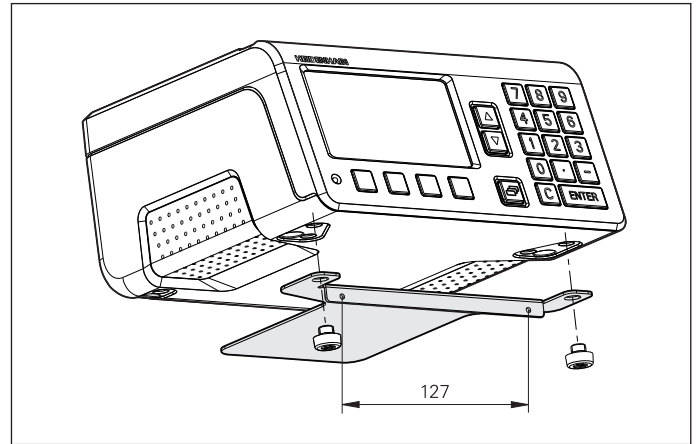

ND 500 series

You can set up the ND 52x either on a mounting arm on the machine, with the aid of a mounting base, or install it in a control panel. The parts required for fastening the display are included in delivery. They enable you to rotate and tilt the display. The mounting arm, mounting base, and mounting frame are available as accessories:

Accessories:

Mounting arm, straight (see page 31)
ID 382893-01

Mounting arm, offset (see page 31)
ID 382929-01

Mounting base
ID 625491-01

Mounting frame
ID 647702-01

For mounting the ND 52x in a housing or operating panel.

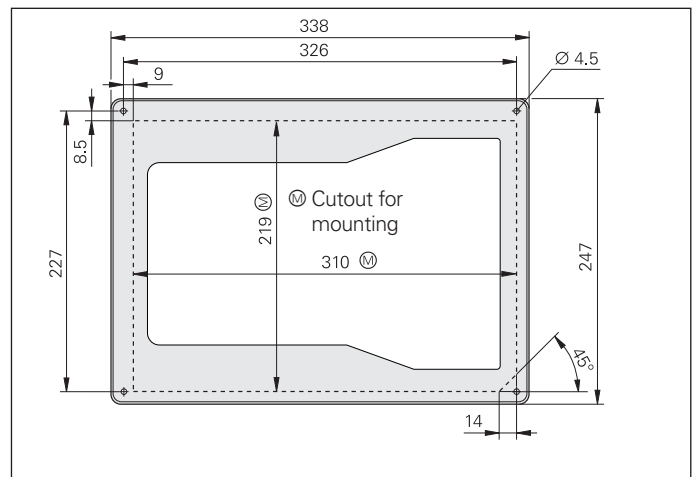
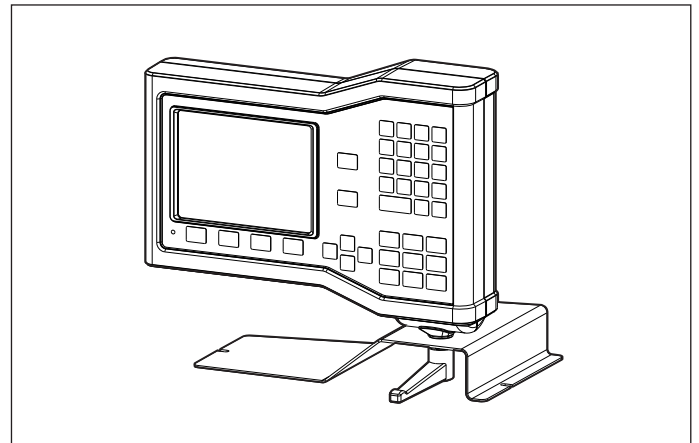

– ND 780

The ND 780 display units were conceived as upright units. There are several possible mounting configurations:

- M4 threaded mounting hole on bottom of housing
- Tilting base
- Mounting frame
- Tilt/swivel assembly
- Mounting arm and tilt/swivel assembly

Accessories

Tilting base

ID 281619-01

The tilting base can be used to tilt the display forward and backward by up to 20°. It can be attached with M5 screws.

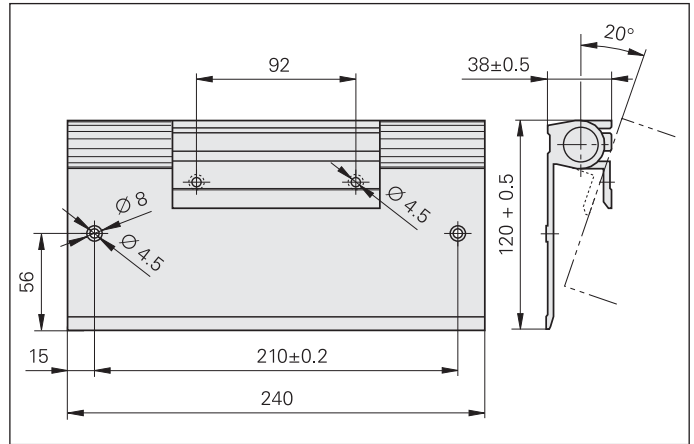

Tilt/swivel assembly

ID 520011-01

The joint permits tilting and rotation of the readout. It can be attached to a machine element or mounting arm with its M8 screws.

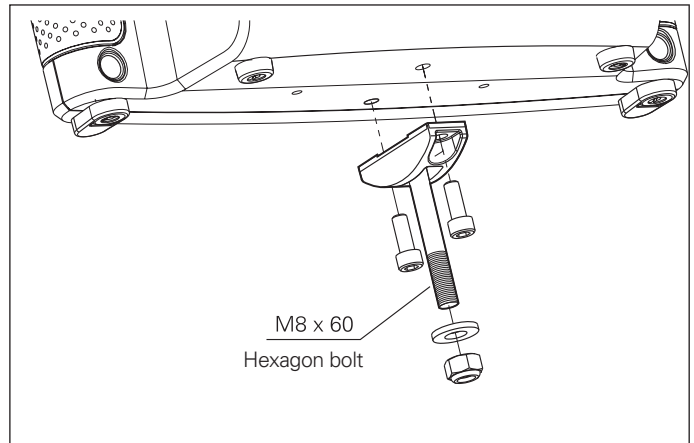

Grip bar

ID 520012-01

The grip bar is attached to the base of the ND 780, and is used to easily swivel the readout.

Mounting arm, straight (see page 31)

ID 382893-01

Mounting arm, offset (see page 31)

ID 382929-01

Mounting frame

ID 532811-01

For mounting the ND 780 in a housing or operating panel.

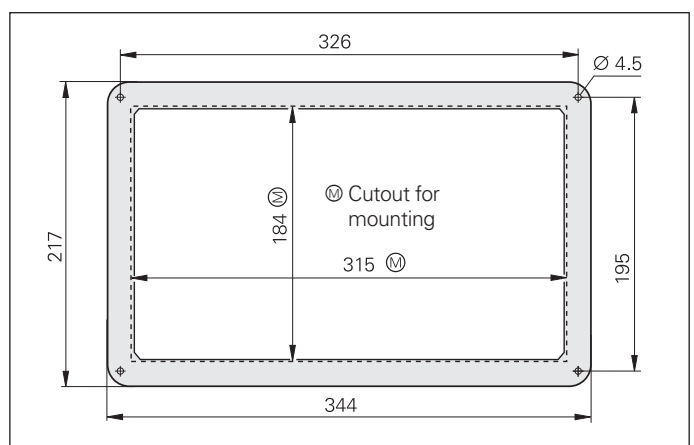

Mounting

– POSITIP 880

The POSITIP 880 was conceived as an upright unit. There are several possible mounting configurations:

- M4 threaded mounting hole on bottom of housing
- Tilting base
- Tilt/swivel assembly
- Mounting arm and tilt/swivel assembly

Accessories

Tilting base

ID 382892-01

It can be used to tilt the display forward and backward by up to 20°. It can be attached with M5 screws.

Tilt/swivel assembly

ID 382891-01

The joint permits tilting and rotation of the readout. It can be attached to a machine element or mounting arm with its M8 screws.

Mounting arm, straight (see page 31)

ID 382893-01

Mounting arm, offset (see page 31)

ID 382929-01

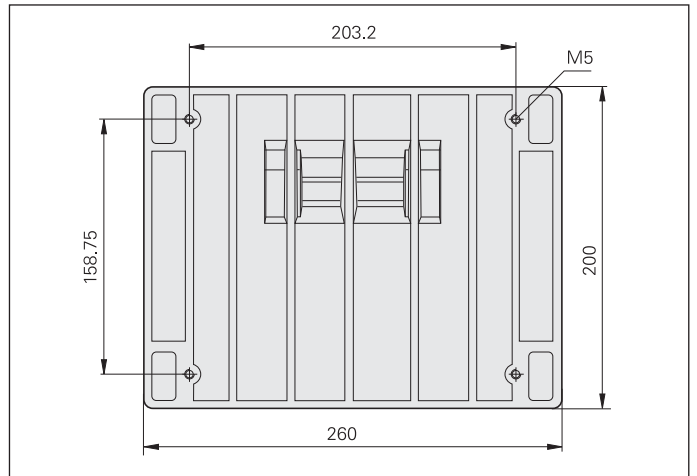
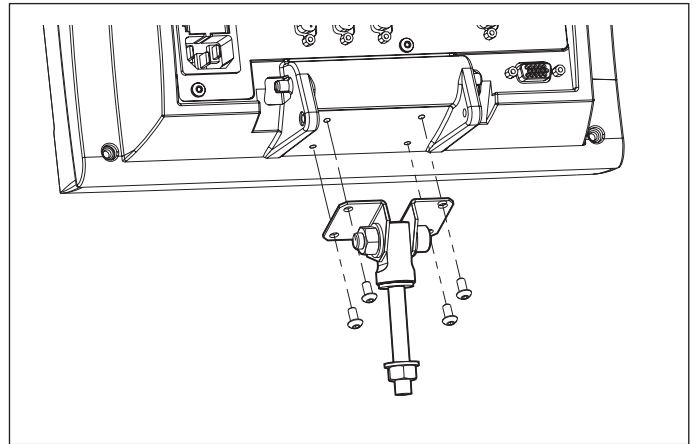

– Mounting arms (accessories for series ND 500, ND 780, POSITIP)

You can use the mounting arm to easily place the display at a conveniently operable position. It can be attached to the machine and swiveled by either a bracket or a hex bolt. The display is attached to the mounting arm via its own tilt/swivel mount.

Accessories:

Mounting arm, straight

ID 382893-01

Mounting arm, offset

ID 382929-01

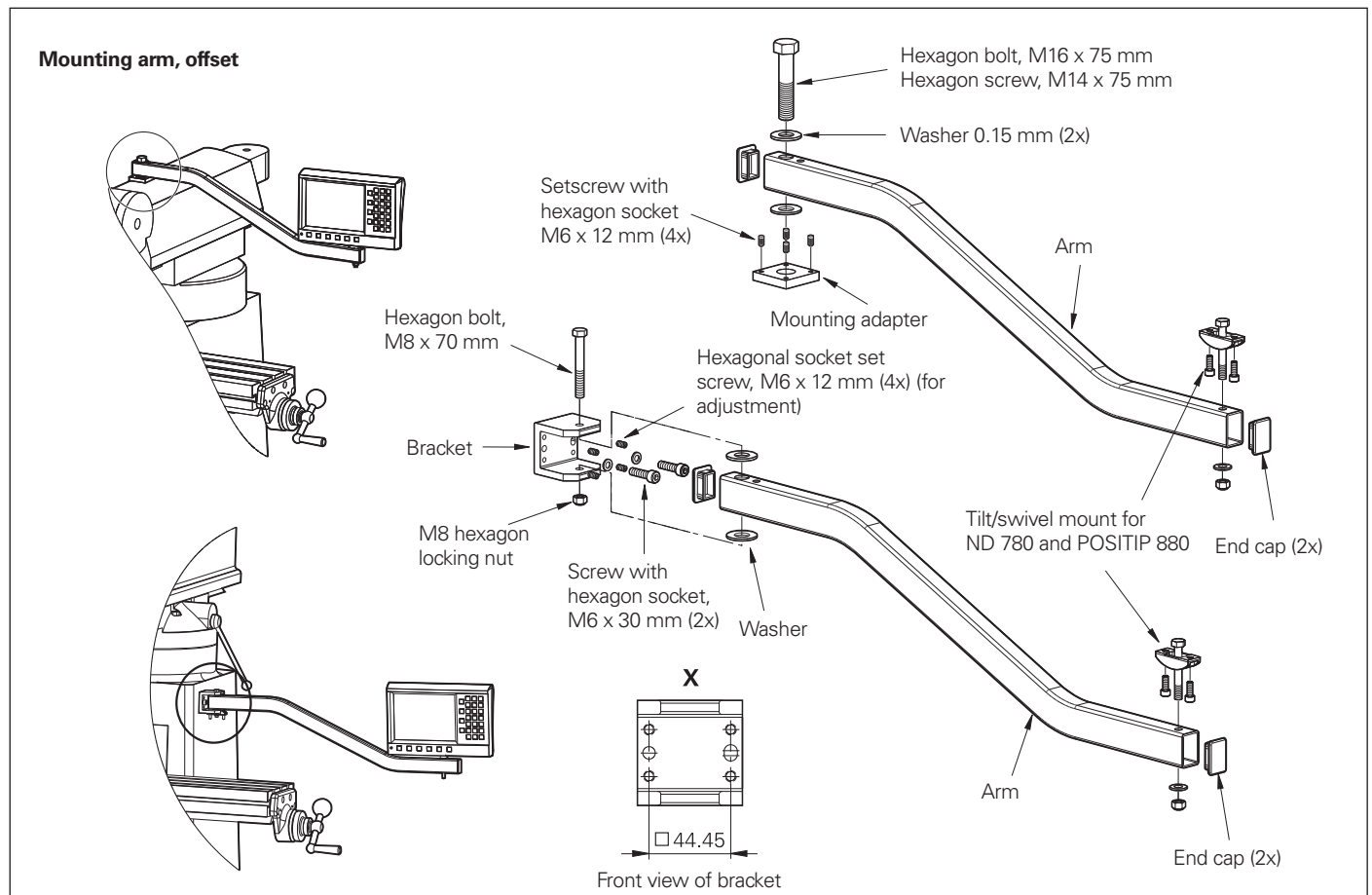
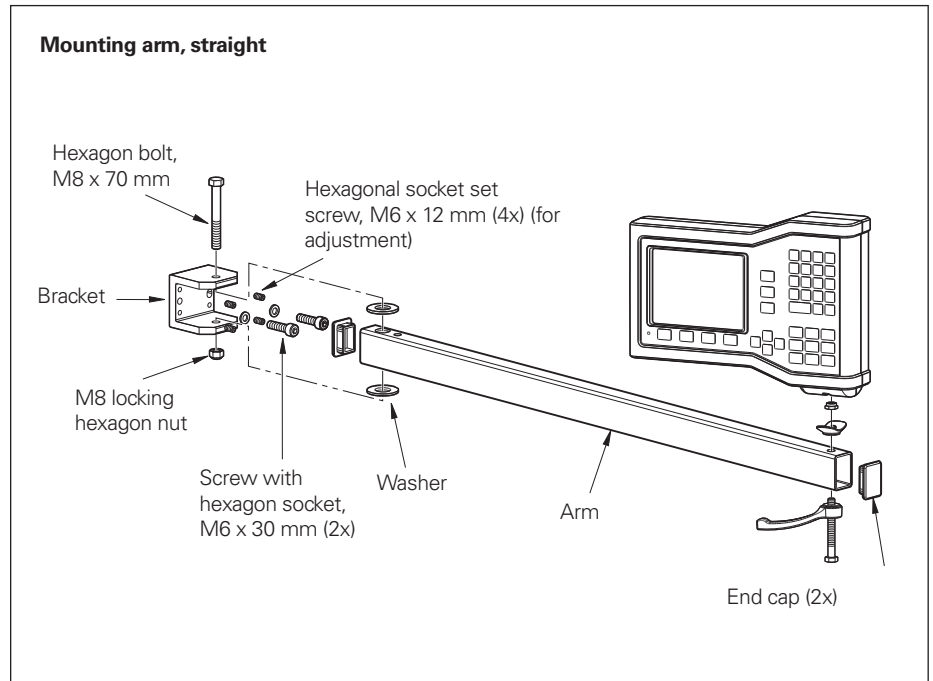

Mounting

Mounting and protection of ND 1200 R

Mounting

The ND 1200 R is shipped with either a tilting base or a mounting base.

Tilting base

The readout can be used as a tabletop unit when placed on the tilting base. The readout can then be tilted forward or backward by up to 20° for the best reading angle. The tilting base can be attached with M5 screws.

ID 382892-02

Mounting adapter

The mounting adapter is used to attach the ND 1200 R to a mounting arm or directly to the machine. It also enables the user to tilt the readout.

ID 682419-01

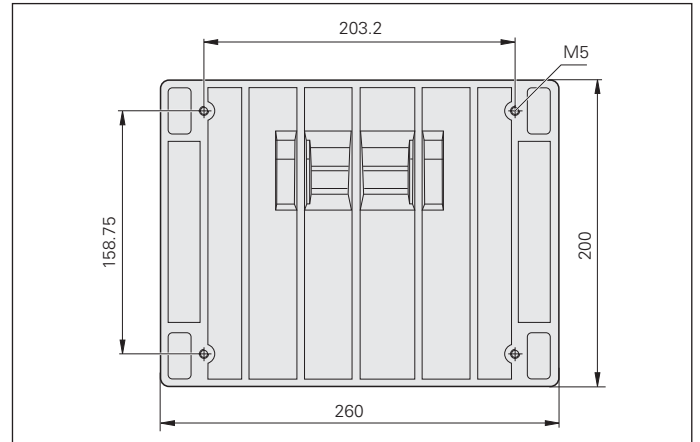

Mounting adapter

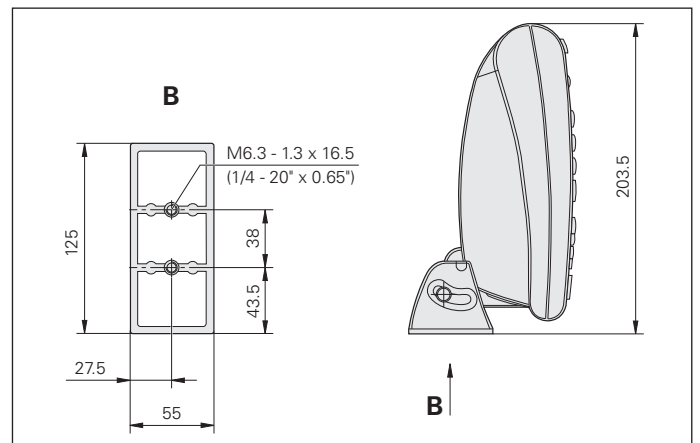

Protective cover (accessory)

Protective covers are accessories for protecting the keyboard and screen of the ND 1200 R from becoming soiled. The display can still be easily read through the transparent protective covers. They fit themselves optimally to the front of the unit, without impairing the ease of operation.

ID 681051-03



Encoders

Connectable encoders

Linear and angle encoders from HEIDENHAIN with various interfaces can be connected to HEIDENHAIN digital readouts (see table).

Connecting a linear or angle encoder

HEIDENHAIN linear and angle encoders can be connected easily and directly to the digital readouts. The versatile readouts from HEIDENHAIN can be adapted to the encoder and the respective operating conditions. The following values can be set via parameters:

- Signal period of the linear encoder
- Line count of the angle or rotary encoder
- Desired display step (resolution)
- Counting direction
- Angle display, etc.

Specifics of connecting rotary encoders

Rotary encoders can also be connected to the readouts in order to measure linear distances via spindle and rotary encoder combinations, or for measuring angles on rotary tables with worm gears. You must take into consideration that the errors of the mechanical transfer elements (spindle-pitch error, reversal error, etc.) directly influence the positioning accuracy. The traverse distance and the display value can be adjusted to each other in the position display unit. With the POSITIP, you can also enter an additional factor (reduction gear).

Signal period for lead screw and rotary encoder combination for linear measurement

Spindle pitch: 10 mm

Line count of the encoder: 1000 lines

Theoretical signal period:

$10 \text{ mm} : 1000 \text{ lines} = 0.01 \text{ mm} = 10 \text{ }\mu\text{m}$

Line count for angular measurement with rotary encoder via a worm gear

Gear ratio 9 : 1

Line count of the encoder:

e.g. 1000 lines

Theoretical line count for angular measurement (any value possible):

$9 \times 1000 \text{ lines} = 9000 \text{ lines}$

| Model | Connectable encoders | Interface | Connecting elements Encoder input |
|------------------------------------|--|---|-----------------------------------|
| ND 280 ND 287 | Incremental linear, angle or rotary encoders | $\sim 1 \text{ V}_{PP}$ $\sim 11 \text{ }\mu\text{A}_{PP}$ | D-sub connector (female), 15-pin |
| | Absolute linear, angle or rotary encoders | EnDat 2.1/2.2 (without incremental signals) | |
| ND 522 ND 523 | Incremental linear and angle encoders | \square TTL | D-sub connector (female), 9-pin |
| ND 780 | Incremental linear and angle encoders | $\sim 1 \text{ V}_{PP}$ $\sim 11 \text{ }\mu\text{A}_{PP}$ | D-sub connector (male) 15-pin |
| POSITIP 880 | Incremental linear, angle or rotary encoders | $\sim 1 \text{ V}_{PP}$ $\sim 11 \text{ }\mu\text{A}_{PP}$ | D-sub connector (male) 15-pin |
| | Absolute linear, angle or rotary encoders | EnDat 2.1 | |
| ND 1202R ND 1203R | Incremental linear, angle or rotary encoders | $\sim 1 \text{ V}_{PP}$ | D-sub connector (male) 15-pin |
| | | \square TTL | D-sub connector (female), 9-pin |

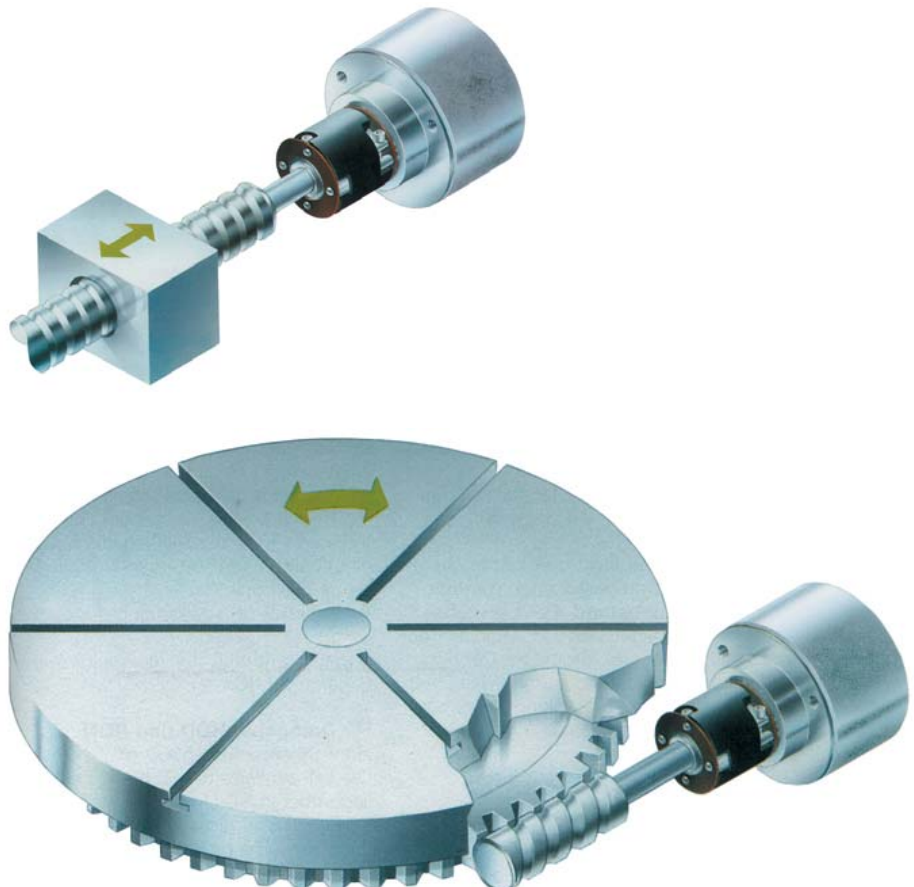

Encoders

Absolute encoders

With absolute encoders from HEIDENHAIN, the position value is available from the encoder immediately upon switch-on, and can be called at any time by the readout. There is no need to move the axes to find the reference position. The absolute position information is read directly from the scale graduation and is output serially as an absolute position value via the bidirectional EnDat interface.

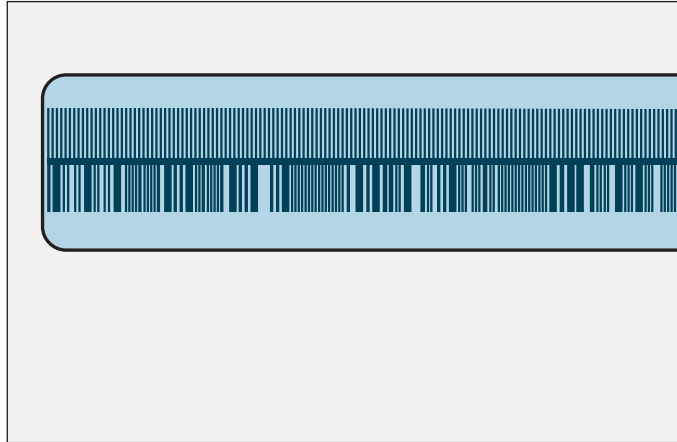

Incremental encoders

Incremental linear and angle encoders from HEIDENHAIN output two sinusoidal signals phase-shifted by 90° as measuring signals, as well as one or more reference mark signals. The readout often subdivides the sinusoidal measuring signal in order to achieve measuring steps smaller than the signal period. The readout often subdivides the sinusoidal measuring signal in order to attain measuring steps smaller than the signal period.

Incremental measurement means measuring by counting. In order to attain an absolute reference, a **reference mark** is applied to the scale. When the reference mark is scanned, a signal associated with exactly one measuring step is generated. In this manner, the association between the position and the display value specified by the **datum setting** is re-established by scanning the reference marks in each axis.

To speed and simplify the referencing procedure, many HEIDENHAIN scales (and graduated disks of angle encoders) have distance-coded reference marks. On these position encoders, the absolute position is already available after scanning two neighboring reference marks. For example, on linear encoders this distance is at most 20 mm (LS, LF) or 80 mm (LB), and for angle encoders a rotation of at most 20°.

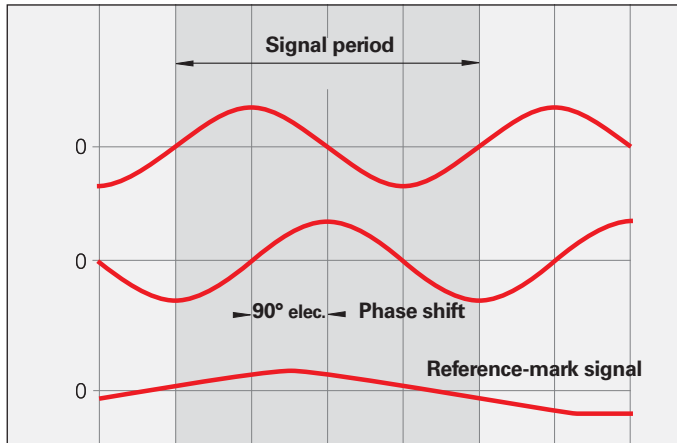



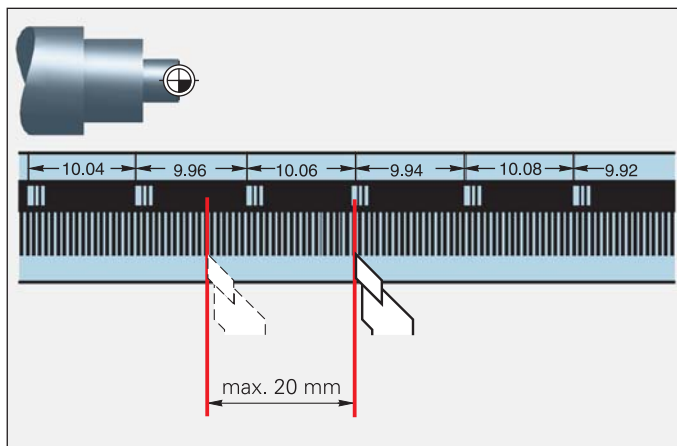







Sinusoidal measuring signals



Traverse with distance-coded reference marks

Interfaces

Digital readouts feature interfaces for encoders, for communication and external operation.

| | ND 280 | ND 287 | ND 522 ND 523 | ND 780 | POSITIP 880 | ND 1200R |
|--------------------------|---|---|---|--|---|--|
| Encoders |  1 V _{PP}  11 μA _{PP} EnDat ¹⁾ |  1 V _{PP}  11 μA _{PP} EnDat ¹⁾ |  TTL |  1 V _{PP}  11 μA _{PP} |  1 V _{PP}  11 μA _{PP} EnDat 2.1 |  1 V _{PP}  TTL |
| Edge finder | – | – | – | <ul style="list-style-type: none"> • KT 130 • Contact triggering | KT 130 | KT 130 |
| Sensors | – | ± 10 V (option) | – | – | – | – |
| Data | <ul style="list-style-type: none"> • RS-232-C/V.24 • USB (UART) | <ul style="list-style-type: none"> • RS-232-C/V.24 • USB (UART) • Ethernet (option) | USB | RS-232-C/V.24 | <ul style="list-style-type: none"> • RS-232-C/V.24 • Centronics | <ul style="list-style-type: none"> • RS-232-C/V.24 • USB (UART) |
| Switching inputs | – | 12 | – | 4 (over IOB 49 input/output unit) | 8 (over IOB 89 input/output unit) | For foot switch |
| Switching outputs | – | 6 | – | 9 (over IOB 49 input/output unit) | 9 (over IOB 89 input/output unit) | – |
| Analog output | – | – | – | 1 (over IOB 49 input/output unit) | – | – |

¹⁾ Purely serial, no evaluation of the incremental signals

Interfaces

– Encoders

The ND and POSITIP digital readouts feature interfaces for connecting encoders from HEIDENHAIN. The ND 287 digital readout can be equipped with a second encoder input.

Accessory for ND 287:

Encoder module

Input assembly for second encoder with 1 V_{PP}, 11 μA_{PP} or EnDat 2.2. interface
ID 654017-01

Pin layout of series ND 200 ~ 1 V_{PP}/~ 11 μA_{PP}/EnDat

Mating connector:
15-pin D-sub connector (male)

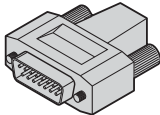
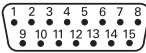
| | Power supply | | | | | Incremental signals | | | | | | Absolute position values | | | |
|---|----------------|-----------------------|----|-----------|-----------------|---------------------|-----------------|-----------------|-----------------|-----------------|-----------------|--------------------------|------|-------|-------|
|  | 4 | 12 | 2 | 10 | 6 | 1 | 9 | 3 | 11 | 14 | 7 | 5 | 13 | 8 | 15 |
| ~ 1 V _{PP} | U _P | Sensor U _P | 0V | Sensor 0V | / | A+ | A- | B+ | B- | R+ | R- | / | / | / | / |
| ~ 11 μA _{PP} | | | | | Internal shield | I ₁₊ | I ₁₋ | I ₂₊ | I ₂₋ | I ₀₊ | I ₀₋ | / | / | / | / |
| EnDat | | | | | | / | / | / | / | / | / | DATA | DATA | CLOCK | CLOCK |

Shield on housing; U_P = power supply voltage

Sensor: The sensor line is connected in the encoder with the corresponding power line.

Pin layout of the ND 500 series □□ TTL

Mating connector:
9-pin D-sub connector (male)

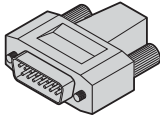
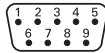





| | Power supply | | Incremental signals | | | | | | Others |
|---|----------------|----|---------------------|-----------------|-----------------|-----------------|-----------------|-----------------|--------|
|  | 7 | 6 | 2 | 3 | 4 | 5 | 8 | 9 | 1 |
| □□ TTL | U _P | 0V | U _{a1} | U _{a1} | U _{a2} | U _{a2} | U _{a0} | U _{a0} | / |

Shield on housing; U_P = power supply voltage

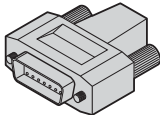
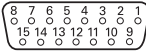
Pin layout ND 780 ~ 1 V_{PP}/~ 11 μA_{PP} PT 880 ~ 1 V_{PP}/~ 11 μA_{PP}/EnDat

Mating connector:
15-pin D-sub connector (female)

| | Power supply | | | | | Incremental signals | | | | | | Absolute position values | | | |
|---|----------------|-----------------------|----|-----------|-----------------|---------------------|-----------------|-----------------|-----------------|-----------------|-----------------|--------------------------|------|-------|-------|
|  | 1 | 9 | 2 | 11 | 13 | 3 | 4 | 6 | 7 | 10 | 12 | 5 | 8 | 14 | 15 |
| ~ 1 V _{PP} | U _P | Sensor U _P | 0V | Sensor 0V | / | A+ | A- | B+ | B- | R+ | R- | / | / | / | / |
| ~ 11 μA _{PP} | | | | | Internal shield | I ₁₊ | I ₁₋ | I ₂₊ | I ₂₋ | I ₀₊ | I ₀₋ | / | / | / | / |
| EnDat | | | | | | A+ | A- | B+ | B- | / | / | DATA | DATA | CLOCK | CLOCK |

Shield on housing; U_P = power supply voltage

Sensor: The sensor line is connected in the encoder with the corresponding power line.

Pin layout of ND 1200R series $\sim 1V_{PP}$

Mating connector:
15-pin D-sub connector (male)

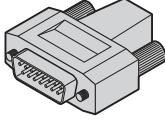
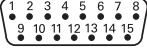
| | Power supply | | | | Incremental signals | | | | | | Others |
|---|-------------------------|------------------------------------|-----------|----------------------|---------------------|-----------|-----------|-----------|-----------|-----------|-------------------------|
|  | 4 | 12 | 2 | 10 | 1 | 9 | 3 | 11 | 14 | 7 | 5/6/8/ 13/15 |
| $\sim 1V_{PP}$ | U_P | Sensor U_P | 0V | Sensor 0V | A+ | A- | B+ | B- | R+ | R- | / |

Cable shield connected to housing; U_P = Power supply voltage

Sensor: The sensor line is connected in the encoder with the corresponding power line.

Vacant pins or wires must not be used!

Pin layout of the ND 1200R series \square TTL

Mating connector:
9-pin D-sub connector (male)

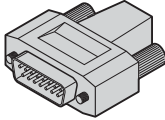
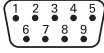
| | Power supply | | Incremental signals | | | | | | Others |
|---|-------------------------|-----------|----------------------------|---------------------------------------|----------------------------|---------------------------------------|----------------------------|---------------------------------------|----------|
|  | 7 | 6 | 2 | 3 | 4 | 5 | 9 | 8 | 1 |
| \square TTL | U_P | 0V | U_{a1} | \overline{U}_{a1} | U_{a2} | \overline{U}_{a2} | U_{a0} | \overline{U}_{a0} | / |

Cable shield connected to housing; U_P = Power supply voltage

Vacant pins or wires must not be used!

Interfaces

– Analog input (option)

The ND 287 digital readout can be equipped through an optional input assembly with an additional analog input connecting a sensor. The input voltage range is interpolated 4096-fold; for a sensor with $\pm 10\text{ V}$ the resolution is therefore 5 mV. The analog module provides 5 V DC, 12 V DC and 24 V DC as power supply for the sensor.

The 5 V (B) and 12/24 V (A) power supplies are galvanically isolated. They must not be used at the same time. A 9-pin D-sub connector is required as mating connector.

Accessories:

Analog module

Input assembly for $\pm 10\text{ V}$ analog sensor
ID 654018-01

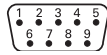

| Pin | Assignment |
|-----|-----------------------------------|
| 1 | - 12 V (A) / 85 mA |
| 2 | 0 V (A) |
| 3 | 0 V (A) |
| 4 | + 12 V (A) / 85 mA |
| 5 | Shield |
| 6 | 0 V (B) |
| 7 | 0 V (B) |
| 8 | Sensor (B) $\pm 10\text{ V}$ max. |
| 9 | + 5 V (B) / 400 mA |

– Serial data transfer

The digital readouts from HEIDENHAIN feature serial data interfaces for connecting a printer or PC. Depending on the readout's features, it can output measured values, measurement series, parameters and programs. It can also load compensation value tables, parameters and programs, and it can be operated remotely through the simulation of keyed-in commands.

There are many possible ways to **start the measured value transfer**:

- From the keyboard with the EXPORT soft key
- By the software command CTRL B
- Via external signal through a pulse or make contact at a D-sub connection (on POSITIP at IOB 89)
- Through deflection of the edge finder (only on ND 780)

USB

The ND 28x and ND 52x digital readouts have a USB interface function with connector type B. The USB interface functions as a UART (Universal Asynchronous Receiver Transmitter). A special driver software is required for operation (free download at www.heidenhain.de). The data are transferred in ASCII code.

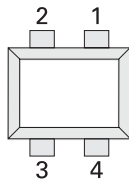

| Pin | Assignment |
|-----|----------------------|
| 1 | V _{CC} + 5V |
| 2 | D- Data - |
| 3 | D+ Data + |
| 4 | GND Weight |

– Serial data transfer

RS-232-C/V.24

This serial interface follows the EIA standard RS-232-C and the CCITT standard V.24. It uses a 9-pin D-sub female connection. The data are transferred in ASCII code. The **data format** is adjustable (default value in bold type):

- Start bit
- **7/8** data bits
- Parity bit (**none**/even/odd)
- **1/2** stop bits

Accessories

Connecting cable, complete with two D-sub connectors (female) 9-pin
ID 366964-xx

Connecting cable, complete with D-sub connector (female) 9-pin and 25-pin (male)
ID 368017-xx

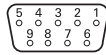

| Pin | Assignment |
|-----|----------------------------|
| 1 | Do not assign |
| 3 | TXD – Transmitted data |
| 2 | RXD – Received data |
| 7 | RTS – Request to send |
| 8 | CTS – Clear to send |
| 6 | DSR – Data set ready |
| 5 | SIGNAL GND – Signal ground |
| 4 | DTR – Data terminal ready |
| 9 | Do not use |

| Signal | Signal levels 1 = active | Signal levels 0 = not active |
|----------------------|-----------------------------|---------------------------------|
| TXD, RXD | –3 V to –15 V | +3 V to +15 V |
| RTS, CTS DSR, DTR | +3 V to +15 V | –3 V to –15 V |

Ethernet (option)

The ND 287 display unit can be equipped with an Ethernet module.

Accessory

Ethernet module
ID 654019-01

The module is provided with an Ethernet interface 100BaseT with RJ45 connector (female, 8-pin). This enables you to connect the ND 287 directly to your company's intranet or, with a crossover cable, to a PC.

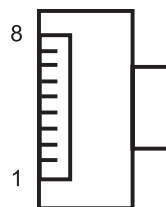

| Pin | Assignment |
|---------|-----------------|
| 1 | TX+ |
| 2 | TX– |
| 3 | REC+ |
| 4 | Do not use |
| 5 | Do not use |
| 6 | REC– |
| 7 | Do not use |
| 8 | Do not use |
| Housing | External shield |

Interfaces

– Switching inputs/outputs on ND 287

Switching inputs

The ND 287 digital readout features many inputs for external operation and outputs for switching functions. The input can respond by pulse or make contact.

Exception: The switching inputs for transmitting measured values over the data interface are separate for contact and pulse.

The switching input E is active when a Low signal U_L is applied (contact or pulse to 0V).

Signal levels

- $0.5V \leq U_L \leq 0.9V$ at $I_L \leq 6mA$
- $3.9V \leq U_H \leq 15.0V$
- $t_{min} \geq 30ms$

Zero reset/preset

Each axis can be set by an external signal to the display value zero or to a value stored in a parameter (SET).

External control of measurement series Switching the display between MIN, MAX or DIFF

With a continuously applied Low signal at the corresponding switching input you activate the external control of measurement series. Starting a measurement series and switching to the MIN/MAX/DIFF display are controlled externally over additional switching inputs.

Ignoring reference mark signals

(disabling the reference pulse)
When the input is active, the readout ignores all reference mark signals. A typical application is for linear measurement through the lead screw and a rotary encoder.

Activating or deactivating REF mode

After switch-on or a power interruption, the digital readout can be switched externally to REF mode. The next signal then deactivates REF mode (switchover function).

Display with axis coupling

As an option, the ND 287 can have two encoder inputs. Using switching inputs, you can switch the display to individual measured values, sum, difference or any logical operation.

| ND 287 | |
|----------------------------|--|
| 12 switching inputs | Reset, clear error message Datum setting Externally control measurement series or display of $X1^{1)}$ Start measurement series or display of $f(X1, X2)^{1)}$ Display minimum MIN or display of $X2^{1)}$ Display maximum MAX or display of $X1 + X2^{1)}$ Display maximum DIFF or display of $X1 + X2^{1)}$ Measured value output (pulse) Measured value output (contact) Ignore reference mark signals (input X1) Ignore reference mark signals (input X2) Activating or deactivating REF mode |
| 6 switching outputs | Display value is zero Measured value \geq switching limit A1 Measured value \leq switching limit A2 Measured value > upper sorting limit Measured value < lower sorting limit Errors |

¹⁾ Also selectable by parameter

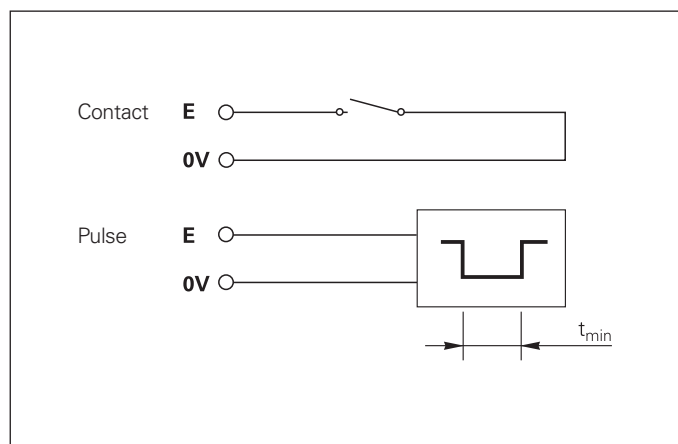

Switching outputs

The ND 287 features open-collector outputs that switch to 0 V (= active Low).

Delay of signal output:

$t_v \leq 20 \text{ ms}$

Signal levels

$U_L \leq 0.4 \text{ V}$ at $I_L \leq 100 \text{ mA}$

$U_H \leq 32 \text{ V}$ at $I_H \leq 10 \mu\text{A}$

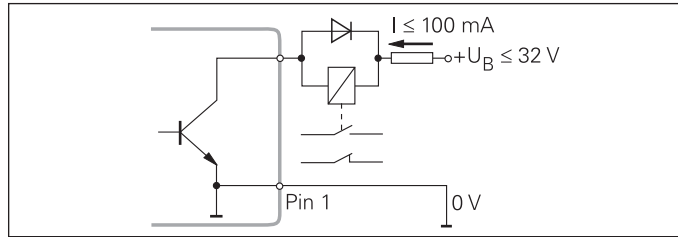

Trigger points

(in actual value mode)

When the measured value reaches trigger points defined by parameter, the corresponding output becomes active. Up to two trigger points can be defined.

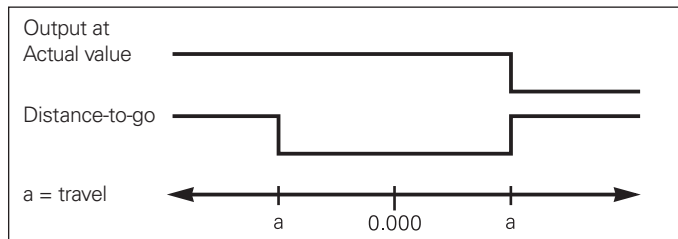

Switch-off ranges

(in distance-to-go mode)

In the distance-to-go mode the trigger points function as switch-off ranges. They are located symmetrically around the display value 0.

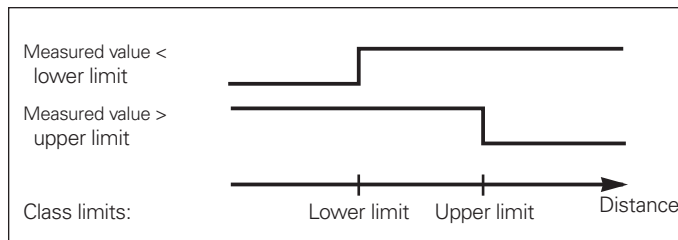

Sorting limits

When the measured value exceeds the limits defined via parameters, the corresponding outputs become active.

Trigger signal for error

The ND 200 series readouts constantly monitor the measuring signals, the input frequency, the data output, etc. for errors, and report errors as they occur with error messages. If an error occurs that may distort the measurement or corrupt the data, the display activates a switching output. This feature allows monitoring of automated processes.

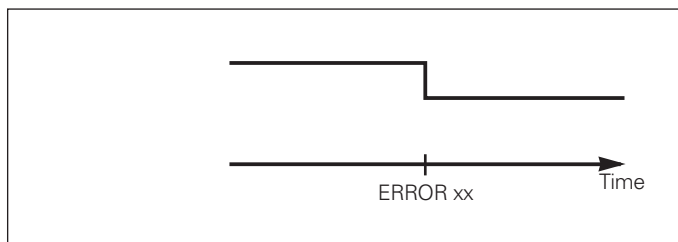

Zero crossover

At the display value "zero," the corresponding output becomes active. The minimum signal duration is 180 ms.

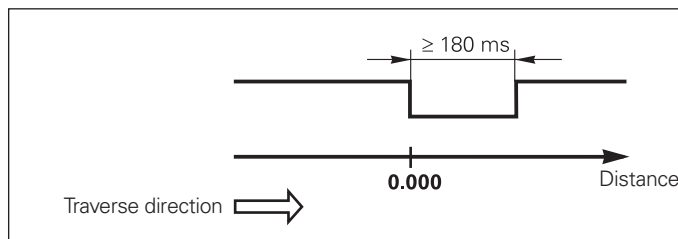

Interfaces

– Switching I/O on ND 780 over IOB 49

The ND 780 provides application-dependent additional functions that are available when the IOB 49 external input/output unit is connected.

IOB 49 external input/output unit

ID 532900-01

The IOB 49 input/output unit is attached to a standard NS 35 rail (DIN 46227 or EN 50022). It is connected to the ND 780 using the touch probe input. LEDs show the power supply, the data transmission and the status of the inputs and outputs.

Accessories:

Connecting cable complete with connector, between IOB 49 and ND 780
ID 532899-xx

Distribution cable complete with connectors, for parallel connection of IOB 49 and KT 130 on ND 780
ID 532909-01

The additional functions can be configured on the ND 780 when the IOB 49 is connected.

| | IOB 49 |
|------------------------------|---|
| 4 switching inputs | Zero reset of axes 1 to 3 (for milling applications) Recognition of max. 3 operating gears (for turning applications) External activation of CSS (for turning applications) |
| 9 switching outputs | 8 relay outputs as switching functions (for milling applications) 1 relay output for readiness |
| 1 analog output | 0 to 10 V (turning mode) for constant surface speed |
| Power supply | Through ND 780 |
| Cable length | ≤ 15 m to the ND 780 |
| Storage temperature | –20 to 70 °C |
| Operating temperature | 0 °C to 45 °C |

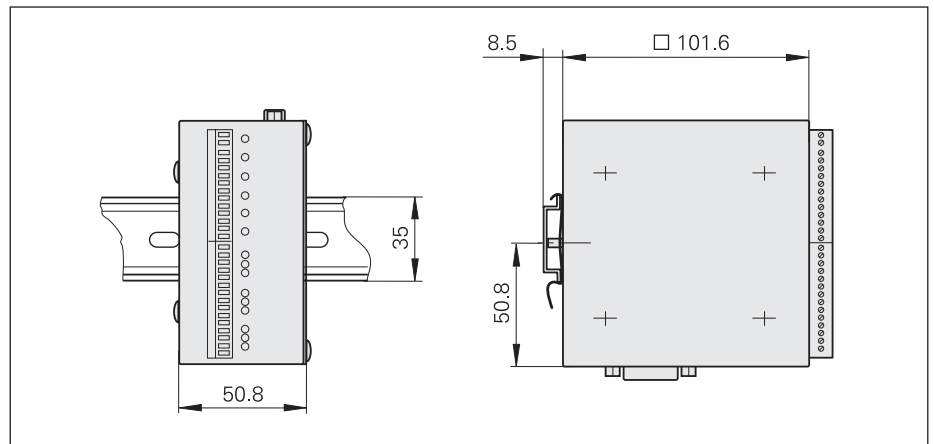

Switching inputs

The switching inputs are active when a High signal (contact or pulse) is present. They are isolated and can be supplied externally or internally.

Signal level of the switching outputs

$$0\text{ V} \leq U_L \leq 1.5\text{ V}$$

$$4.5\text{ V} \leq U_H \leq 26\text{ V}$$

$$I_L \leq 25\text{ mA}$$

$$t_{\min} \geq 100\text{ ms}$$

Zero reset

In the milling mode, each axis can be set to the display value 0 over an external signal.

Detection of gear ranges

In the turning mode, three switching inputs are available for the recognition of gear ranges.

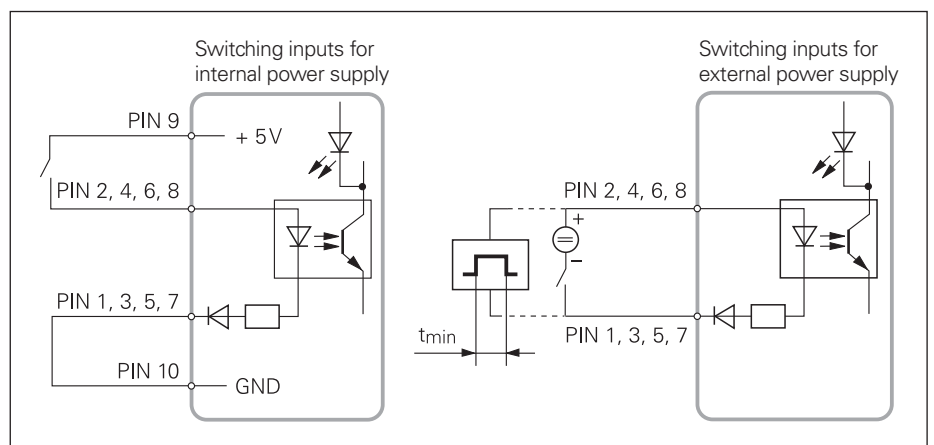

Switching outputs

The IOB 49 features nine floating relay outputs.

Readiness

The readiness output is at LOW level when the ND 780 cannot operate the IOB (e.g. not switched on, cable disconnected).

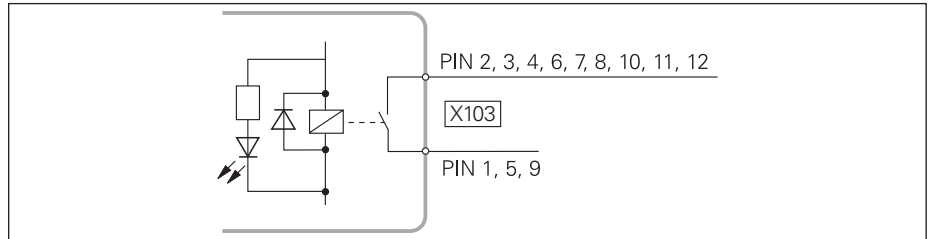

Switching functions

(milling mode)

One or more switching ranges or switching points can be defined for an axis. **Switch-off ranges** lie symmetrically to the 0 display value. If **switching points** are used, the relay activates when the position display reaches a specific value. The **direction** function switches when the algebraic sign is changed.

You can set whether

- the switching function should apply to the actual value or distance-to-go mode,
- the relay will open or close when the condition is met,
- or the relay remains activated as long as the switching condition is met (continuous mode) or for a specified duration (pulsed mode).

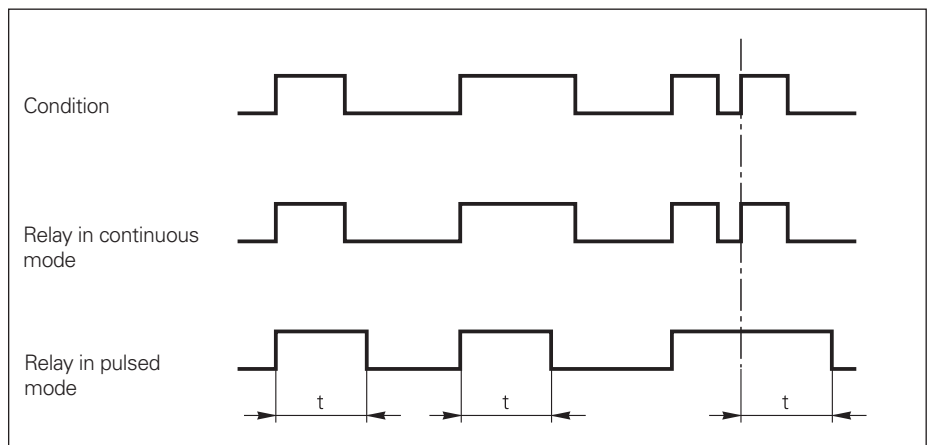
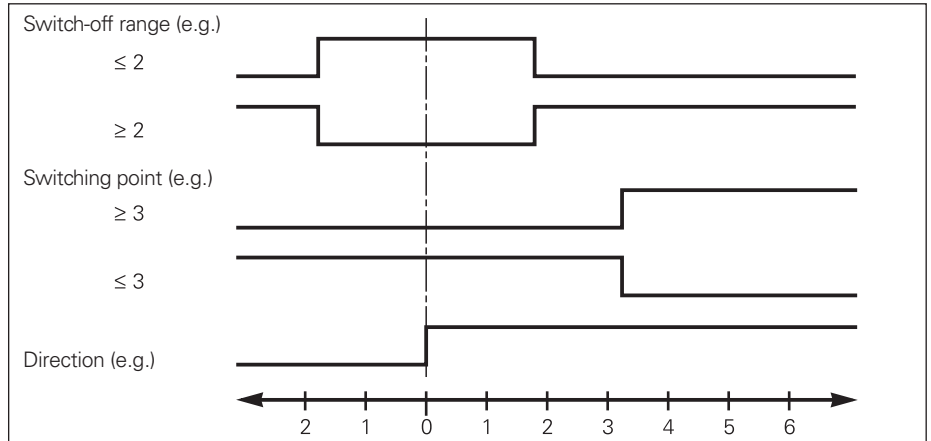

Analog output

Constant surface cutting speed CSS

(in turning mode)

CSS provides spindle speed control as the diameter of the workpiece changes. A speed command signal is sent to the inverter of the spindle motor via the analog interface (DAC 0V to 10V) of the IOB 49. The maximum and minimum permissible spindle speeds can be specified. In addition, a maximum of three operating gears can be taken into account. The ND 780 recognizes the current gear selection by means of the switching inputs of the IOB 49. CSS control can also be started remotely (via an input to the CSS board) with an external switch.

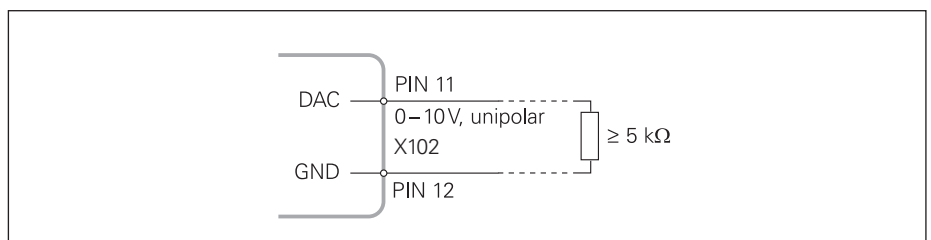

Interfaces

– Switching I/O on POSITIP 880 over IOB 89

The POSITIP 880 features switching functions that you can define as desired. The IOB 89 external input/output unit is necessary to output the switching signals.

IOB 89 external input/output unit ID 532884-01

The IOB 89 input/output unit is attached to a standard NS 35 rail (EN 50022 or DIN 46227). It is connected to the POSITIP 880 via the auxiliary machining interface (AMI). LEDs show the status of the inputs and outputs.

Accessory:

Connecting cable complete with connector, between IOB 89 and POSITIP 880
ID 532856-xx

| | IOB 89 |
|--|--|
| 8 switching inputs | <ul style="list-style-type: none"> • Zero axes 1 to 6 • Start data output (contact or pulse) |
| 9 switching outputs | 8 freely definable switching functions 1 switching output ready for POSITIP 880 |
| Power supply | <i>Device:</i> 24 V DC \pm 20 %/max. 1 A <i>Inputs:</i> 5 V DC or 24 V DC \pm 20 %/min. 0.25 A |
| Cable length | Max. 10 m to POSITIP 880 |
| Storage temperature Operating temperature | -20 to 70 °C 0 °C to 45 °C |

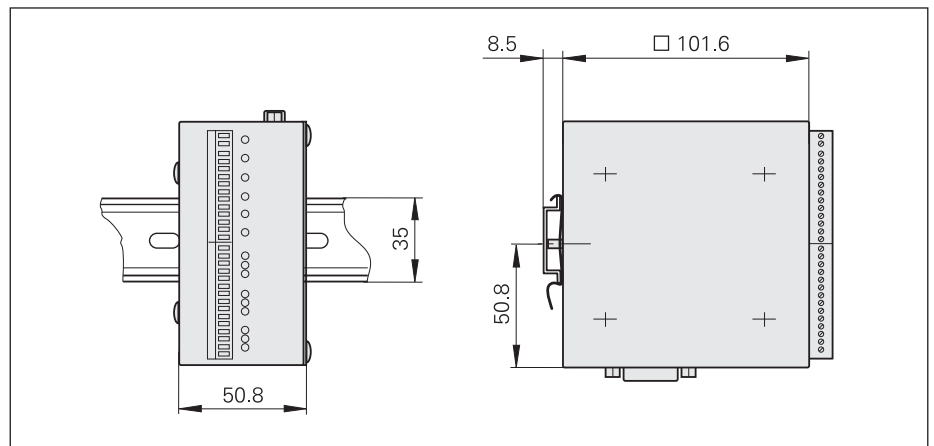

Switching inputs

All switching inputs respond either to contact or pulse.

Exception: The switching inputs for transmitting measured values over the data interface are separate for contact and pulse.

The switching input E is active when a Low signal U_L is applied (contact or pulse to 0V).

Signal levels

- $0.5\text{ V} \leq U_L \leq 0.9\text{ V}$ at $I_L \leq 6\text{ mA}$
- $3.9\text{ V} \leq U_H \leq 15.0\text{ V}$
- $t_{\min} \geq 30\text{ ms}$

Zero reset

Each axis can be set to the display value 0 over an external signal.

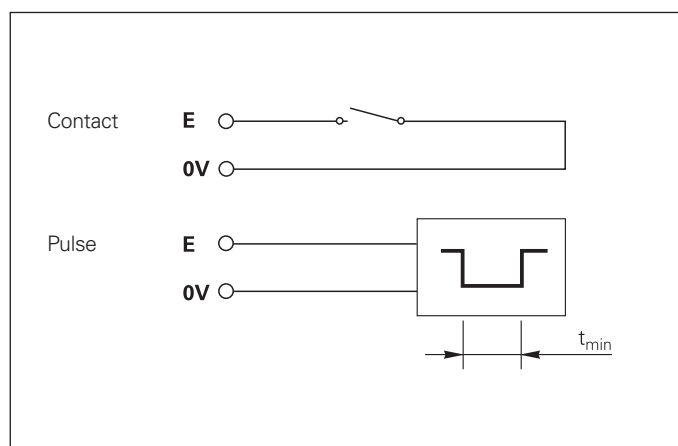

Switching outputs

Signal level of the switching outputs

$U_L \leq 1.5\text{ V}$ at $I_L \leq 100\text{ mA}$

$U_H \leq 24\text{ V}$ at $I_H \leq 0.3\text{ mA}$

Delay until signal output

$t_V \leq 10\text{ ms}$

Readiness

This permanently available output is at LOW level when the POSITIP 880 cannot operate the IOB (e.g. not switched on, cable interrupted).

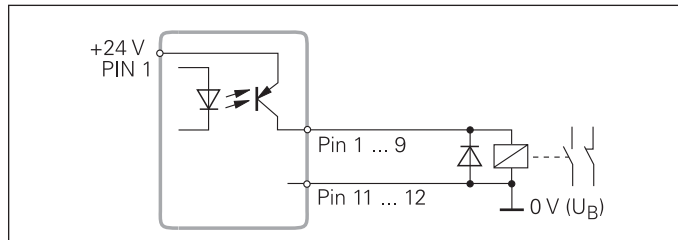

Switching I/O functions

The switching outputs can be configured on the POSITIP 880 when the IOB 89 is connected, and assigned to any axes. The following functions are possible:

Output of the traverse direction

The output switches with each change of the direction of traverse.

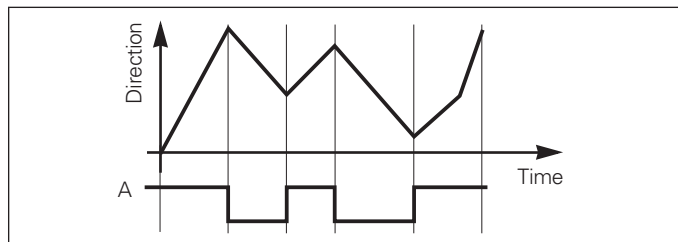

Switch-off ranges

The switch-off ranges are located symmetrically around the display value 0. They can be assigned to the axes in any manner. In the distance-to-go display mode (traverse to 0), switch-off signals are generated for any target position.

Trigger points

The output switches at the programmed position. The algebraic sign is taken into account.

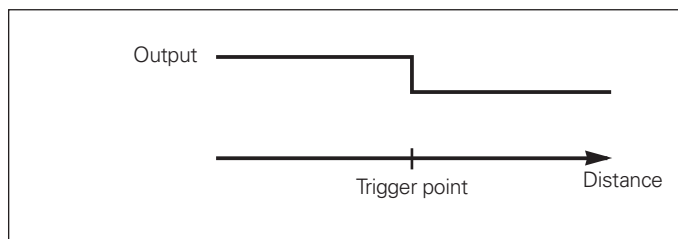
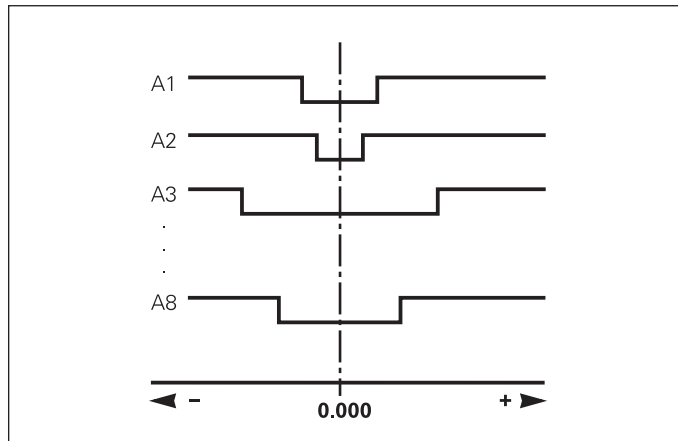

Accessories

– External operating element for ND 1200 R

With the foot switch you can remotely operate the ND 1200 R, e.g. to switch to the next drilling position.

Foot switch (accessory)

With two freely assignable keys

Cable length: 2.4 m

For ND with RJ 45 connector

ID 681041-01



Foot switch

Cable overview

– ND 28x, ND 52x

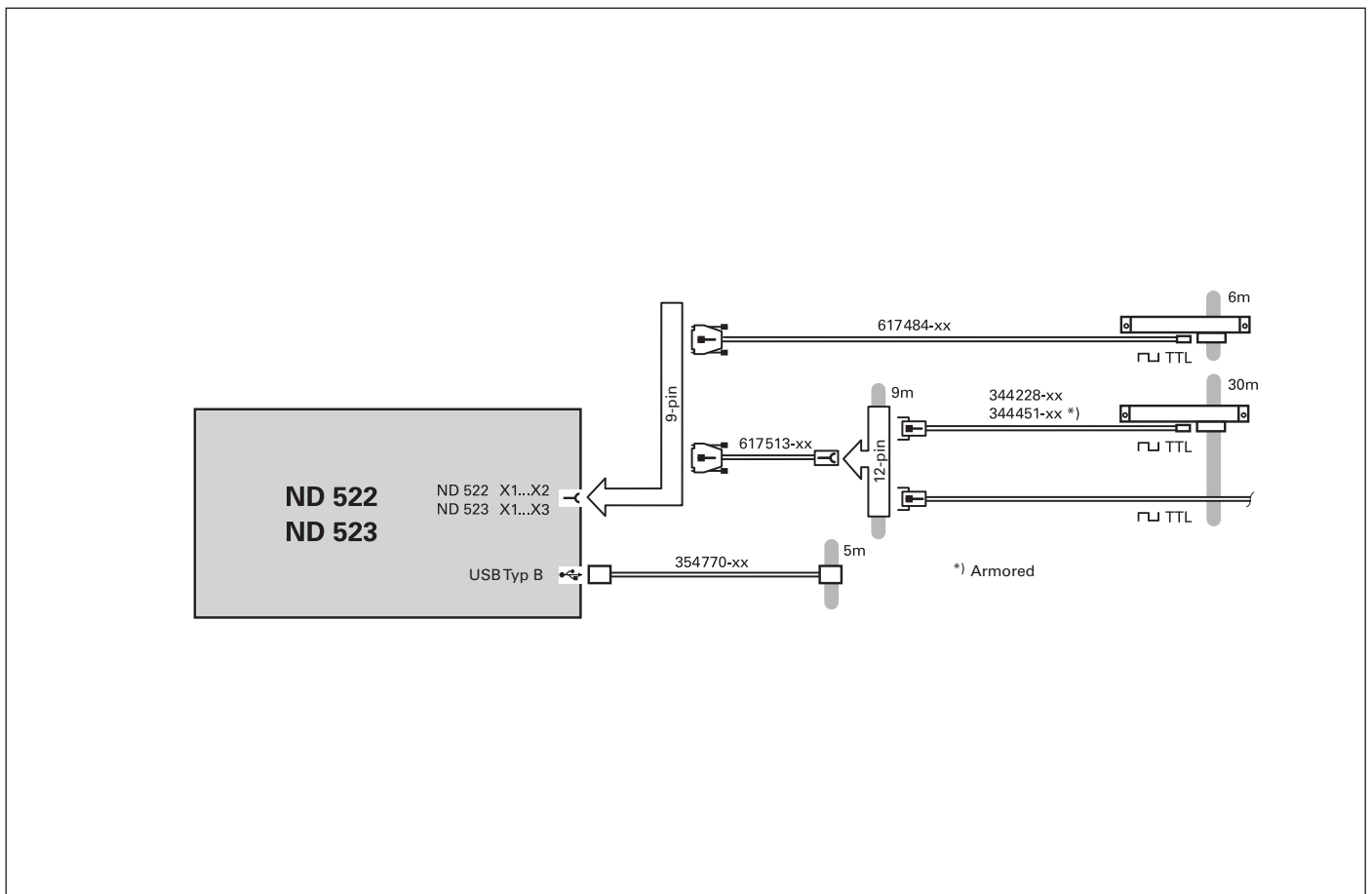
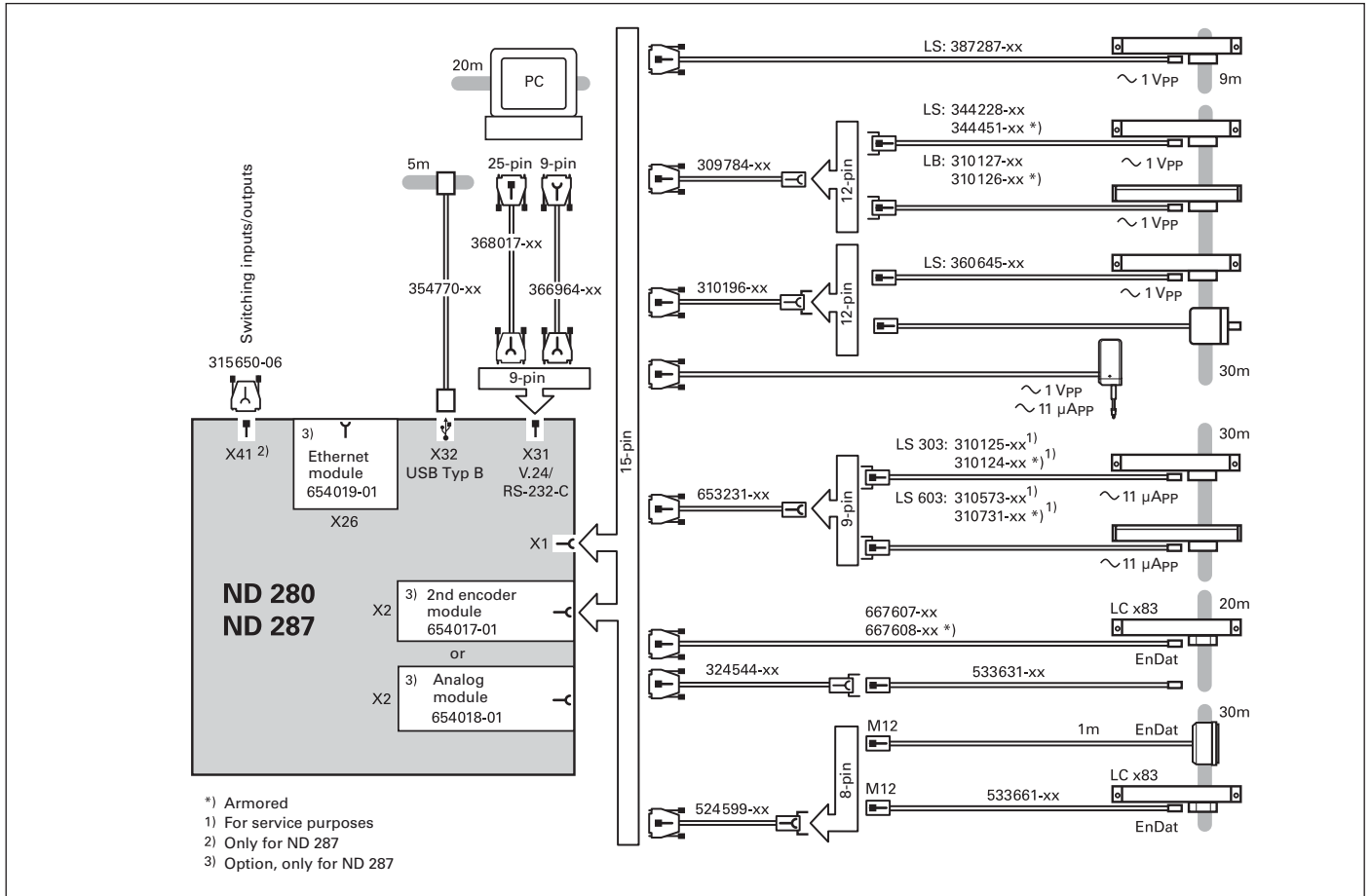

Cable overview

– ND 780, POSITIP

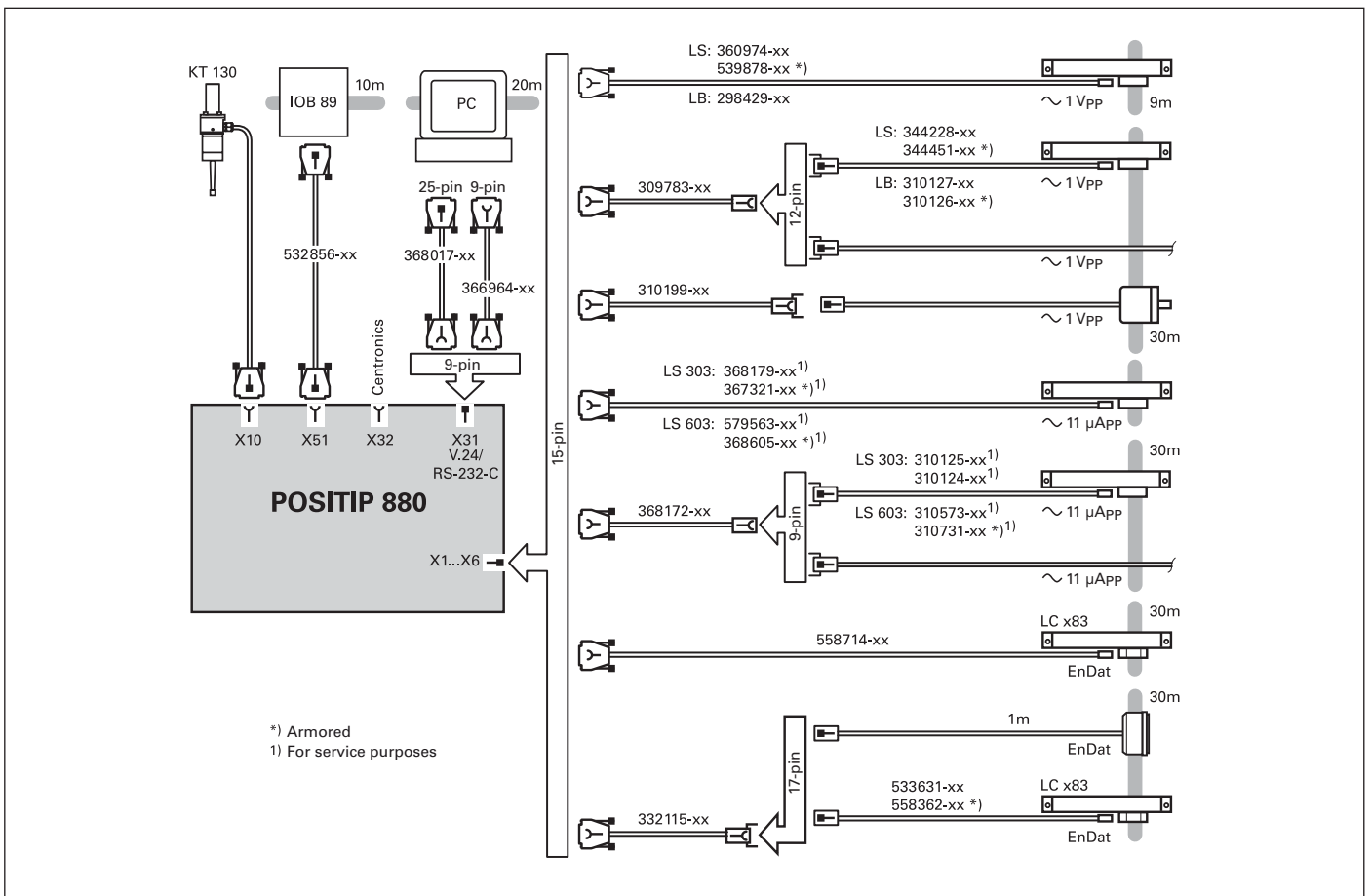
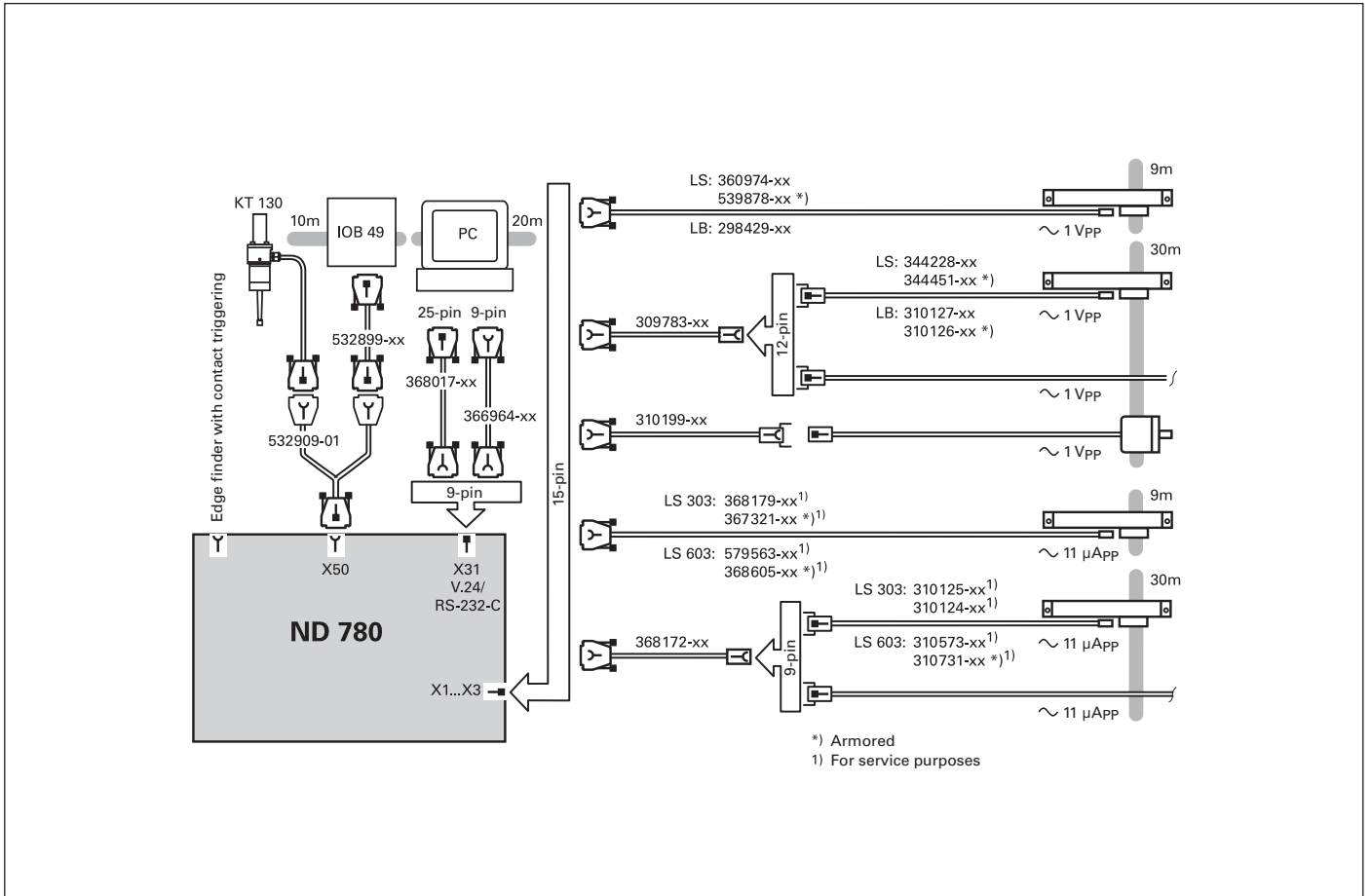

- ND 120xR

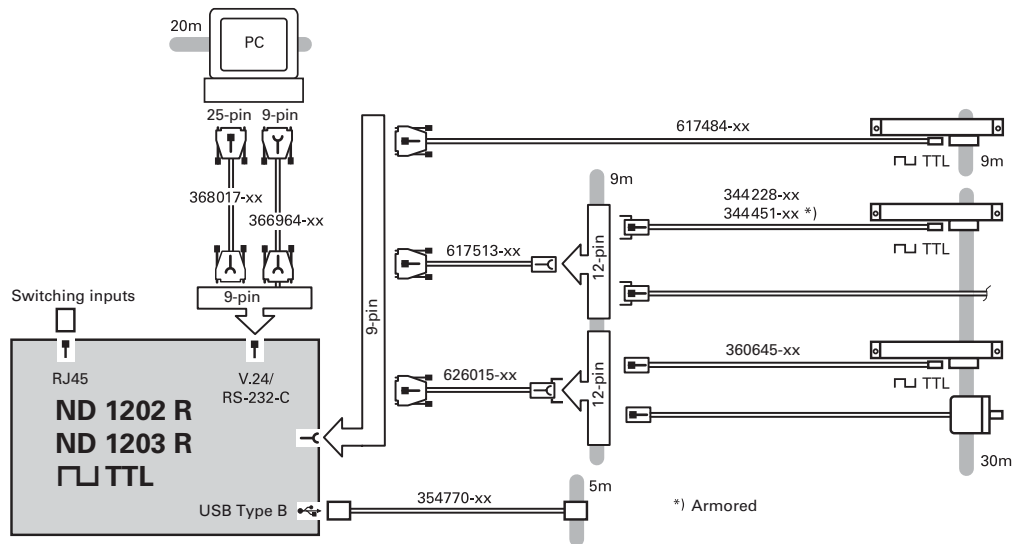
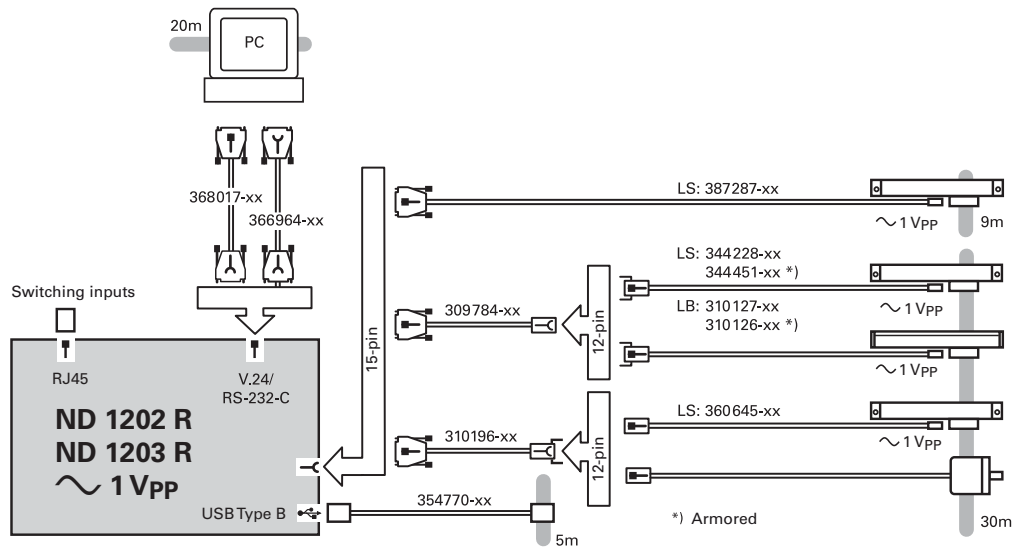

Linear encoders

– For manually operated machine tools

For typical applications on manual machine tools such as milling machines or lathes, **display steps of 10 µm or 5 µm** are sufficient. Such display steps are provided by the LS 300 and LS 600 series linear encoders with an accuracy grade of $\pm 10 \mu\text{m}$ per meter traverse.

Jig boring machines, grinding machines, and measuring and inspection tasks normally require **display steps of 1 µm** and better. Linear encoders for these more stringent requirements typically feature accuracy grades of $\pm 5 \mu\text{m}$ per meter traverse.

These linear encoders, such as LS 487 or LS 187, are described in the *Linear Encoders for Numerically Controlled Machine Tools* brochure.

For **limited installation space**, for example on the slide of a lathe, linear encoders may be the best solution.

The linear encoders with full-sized scale housing function as universal linear encoders under **normal mounting conditions**.

Linear encoders for large traverses

On large boring or milling machines, but also on lathes with long Z axes, traverse ranges can extend three meters and more. HEIDENHAIN has the proper linear encoders for such special applications.

The **LB 382** with full-sized scale housing makes **measuring lengths of up to 30040 mm possible**. The housing is assembled from sections and mounted on the machine, and the single steel scale tape is then pulled into its slot.

The LB 382 is listed in the *Linear Encoders for Numerically Controlled Machine Tools* brochure.

Absolute linear encoders

Encoders for absolute position measurement are used on machines and equipment where axis positions must already be known upon switch-on. The LC 415, LC 115 and LC 200 absolute linear encoders are described in the *Linear Encoders for Numerically Controlled Machine Tools* brochure. A product information sheet is available for the LC 183 and LC 483.

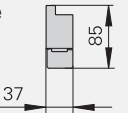
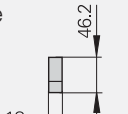
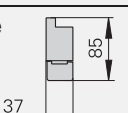
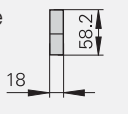
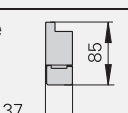
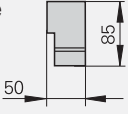
| | Scale housing | Accuracy grade | Measuring lengths |
|---|---|--|--|
| Recommended measuring steps 10 µm, 5 µm | | | |
| Incremental linear measurement • Glass scale | Slimline LS 388: 46.2 LS 328: 58.1  | $\pm 10 \mu\text{m}$ | 70 mm to 1240 mm |
| | Full size  | $\pm 10 \mu\text{m}$ | 140 mm to 3040 mm |
| Recommended measuring steps 1 µm, 0.5 µm and finer | | | |
| Incremental linear measurement • Glass scale | Slimline  | $\pm 5 \mu\text{m}$ $\pm 3 \mu\text{m}$ | 70 to 1240 mm <i>With mounting spar:</i> 70 mm to 2040 mm |
| | Full size  | $\pm 5 \mu\text{m}$ $\pm 3 \mu\text{m}$ | 140 mm to 3040 mm |
| Absolute linear measurement • Glass scale | Slimline  | $\pm 5 \mu\text{m}$ $\pm 3 \mu\text{m}$ | 70 to 1240 mm <i>With mounting spar or clamping elements:</i> 70 mm to 2040 mm |
| | Full size  | $\pm 5 \mu\text{m}$ $\pm 3 \mu\text{m}$ | 140 mm to 3040 mm |
| Recommended measuring steps 10 µm, 5 µm, 1 µm | | | |
| Incremental linear measurement for large measuring lengths • Steel scale tape | Full size  | $\pm 5 \mu\text{m}$ | 440 mm to 30040 mm |
| Absolute linear measurement for large measuring lengths • Steel scale tape | | | 4240 mm to 28040 mm |



LB 382

| | Incremental signals/ Signal period | Absolute position values | Model | For more information |
|--|---------------------------------------|--------------------------|----------------|--|
| | \sim 1 V _{PP} ; 20 μm | – | LS 388C | Page 46 |
| | \square TTL; 20 μm | | LS 328C | |
| | \sim 1 V _{PP} ; 20 μm | | LS 688C | Page 48 |
| | \square TTL; 20 μm | | LS 628C | |
| | \sim 1 V _{PP} ; 20 μm | – | LS 487 | Catalog <i>Linear Encoders for Numerically Controlled Machine Tools</i> |
| | \square TTL; To 1 μm | | LS 477 | |
| | \sim 1 V _{PP} ; 20 μm | | LS 187 | * Product Information LC 183 LC 483 |
| | \square TTL; To 1 μm | | LS 177 | |
| | – | EnDat 2.2/22 | LC 415 | |
| | \sim 1 V _{PP} ; 20 μm | EnDat 2.2/02 | LC 483* | |
| | – | EnDat 2.2/22 | LC 115 | |
| | \sim 1 V _{PP} ; 20 μm | EnDat 2.2/02 | LC 183* | |
| | \sim 1 V _{PP} ; 40 μm | – | LB 382 | Catalog <i>Linear Encoders for Numerically Controlled Machine Tools</i> |
| | \sim 1 V _{PP} ; 40 μm | EnDat 2.2/02 | LC 281 | |
| | – | EnDat 2.2/22 | LC 211 | |



LS 388C



LS 688C



LS 487/LC 415



LS 187/LC 115



LS 281/LC 211



Mounting information

– Slimline linear encoders

LS 300 series

The slimline linear encoders should be fastened over their entire length onto a machined surface. The encoder is mounted so that the sealing lips are directed downward or away from splashwater.

Mounting

It is surprisingly simple to mount the LS 300 sealed linear encoders: you need only align the scale unit at several points along the machine guideway. Stop surfaces or stop pins can also be used to align the scale.

Use the mounting gauge to easily and quickly set the gap between the scale housing and the scanning unit. Ensure that the lateral tolerances are also maintained.

Accessory

Mounting gauge

ID 528753-01

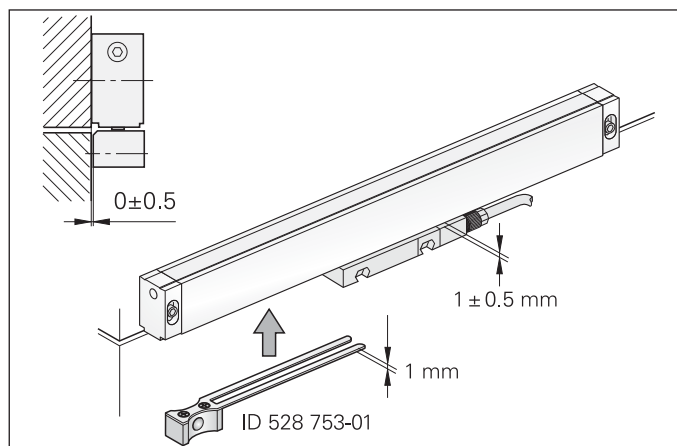
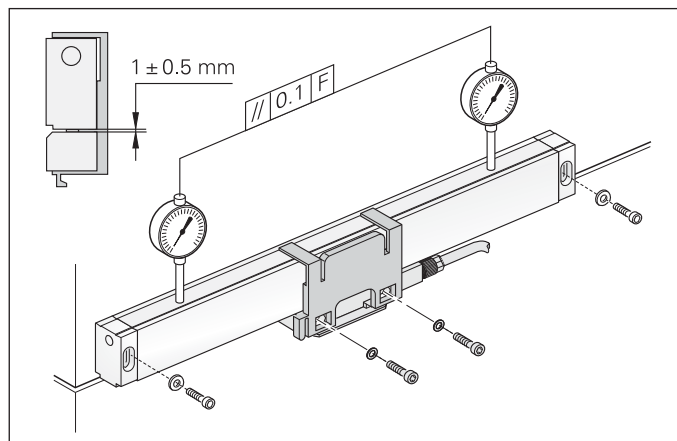

– Full-size linear encoders

LS 600 series

The full-size linear encoders are fastened to a machined surface only at the ends with their mounting blocks. Measuring lengths over 620 mm (24.4 in) require one or more support brackets to improve vibration behavior.

The inclined arrangement of the sealing lips permits universal mounting with vertical or horizontal scale housing with equally high protection rating.

Mounting

When mounting the LS 600, the shipping brace already sets the proper gap between the scale unit and the scanning unit. You need only align the scale unit at several points along the machine guideway.

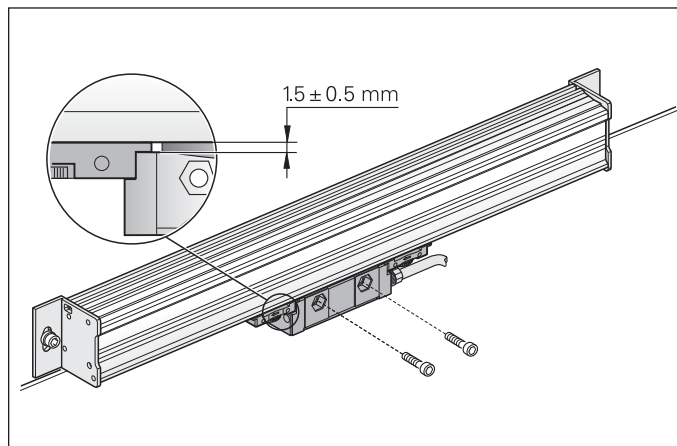
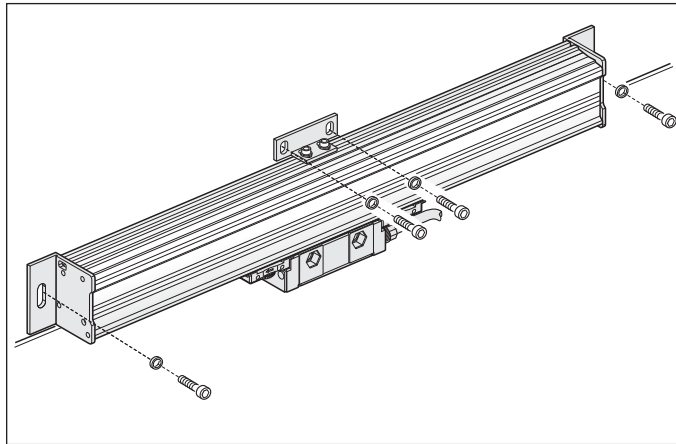

LS 300 series

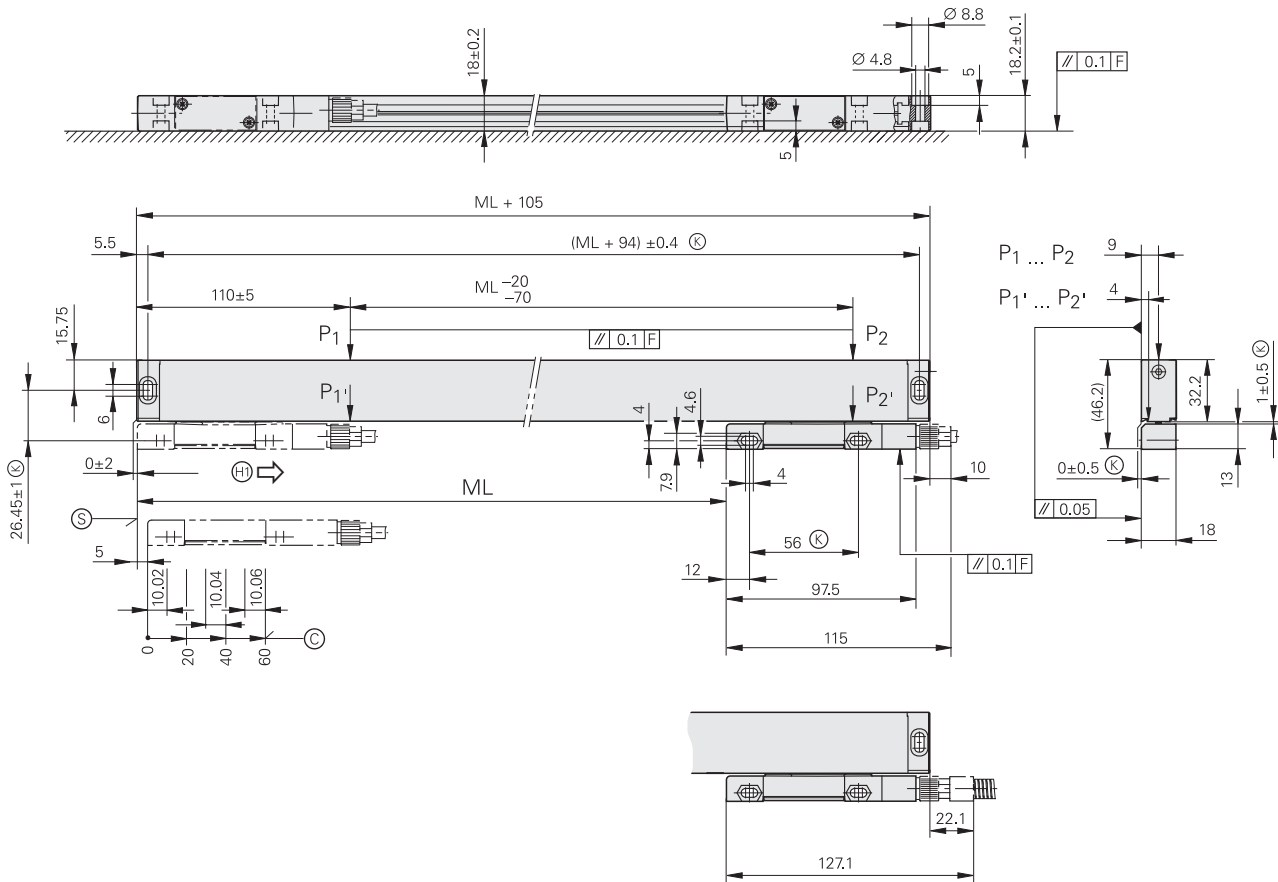

mm



Tolerancing ISO 8015
ISO 2768 - m H
< 6 mm: ± 0.2 mm

Ⓢ = Beginning of measuring length (ML)

Ⓞ = Reference mark position

F = Machine guideway

P = Gauging points for alignment

Ⓚ = Required mating dimensions



| Specifications | Incremental | |
|--|--|---------|
| | LS 388C | LS 328C |
| Measuring standard | Glass scale with DIADUR graduation | |
| Accuracy grade | ± 10 µm | |
| Measuring length ML* | 70 120 170 220 270 320 370 420 470 520 570 620 670 720 770 820 870 920 970 1020 1140 1240 | |
| Incremental signals | ~ 1 V _{PP} | □TTL |
| Grating period | 20 µm | |
| Edge separation a | – | ≤ 5 µs |
| Reference mark | Distance-coded | |
| Recommended measuring step¹⁾ | 10 µm, 5 µm | |
| Power supply | 5 V DC ± 5 % / < 100 mA (without load) | |
| Electrical connection | Separate adapter cable connectable to mounting block | |
| Cable length | ≤ 30 m (with HEIDENHAIN cable) | |
| Traversing speed | ≤ 60 m/min | |
| Required moving force | ≤ 5 N | |
| Vibration 55 Hz to 2000 Hz Shock 6 ms | ≤ 150 m/s ² (EN 60068-2-6) ≤ 300 m/s ² (EN 60068-2-27) | |
| Operating temperature | 0 °C to 50 °C | |
| Protection EN 60529 | IP 53 when mounted according to the instructions | |
| Weight | 0.27 kg + 0.67 kg/m ML | |

* Please select when ordering

¹⁾ For position measurement

Please refer to the *General Electrical Information*—especially for connection to non-HEIDENHAIN electronics—at www.heidenhain.de/docu.

LS 600 series

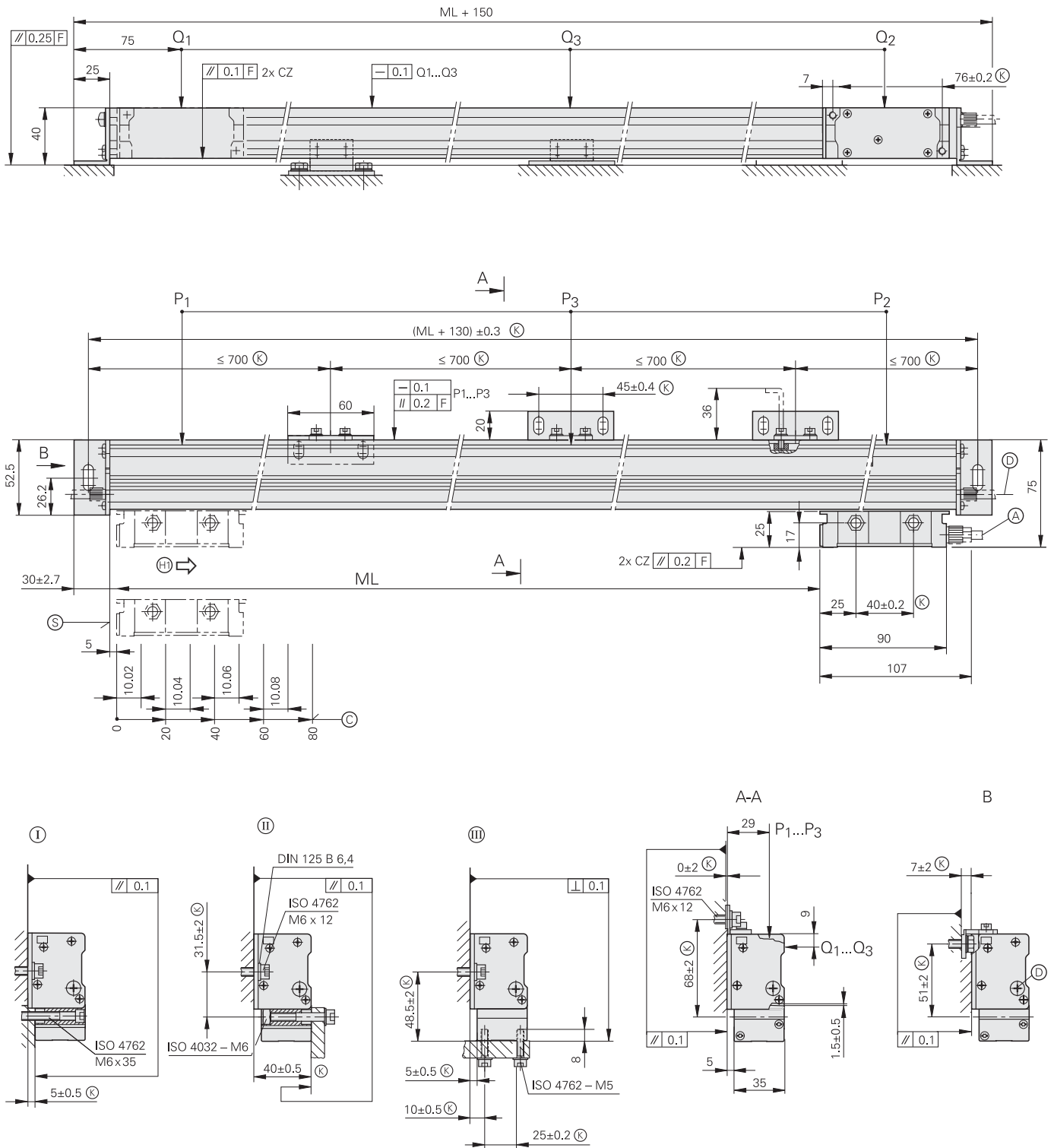

mm

Tolerancing ISO 8015
ISO 2768 - m H
< 6 mm: ± 0.2 mm

- ①, ②,
- ③ = Mounting options
- F = Machine guideway
- P, Q = Gauging points for alignment
- Ⓐ = Cable connection usable at either end
- Ⓑ = Compressed air inlet usable at either end
- Ⓚ = Required mating dimensions
- Ⓢ = Beginning of measuring length (ML)
- Ⓒ = Reference-mark position on LS 6x8C



| Specifications | Incremental | |
|--|--|---------|
| | LS 688C | LS 628C |
| Measuring standard | Glass scale with DIADUR graduation | |
| Accuracy grade | ± 10 µm | |
| Measuring length ML* | 170 220 270 320 370 420 470 520 570 620 670 720 770 820 870 920 970 1020 1140 1240 1340 1440 1540 1640 1740 1840 2040 2240 2440 2640 2840 3040 | |
| Incremental signals | ~ 1 V _{PP} | □TTL |
| Grating period | 20 µm | |
| Edge separation a | – | ≤ 5 µs |
| Reference mark | Distance-coded | |
| Recommended measuring step¹⁾ | 10 µm, 5 µm | |
| Power supply | 5 V DC ± 5 % / < 100 mA (without load) | |
| Electrical connection | Separate adapter cable connectable to mounting block | |
| Cable length | ≤ 30 m (with HEIDENHAIN cable) | |
| Traversing speed | ≤ 60 m/min | |
| Required moving force | ≤ 5 N | |
| Vibration 55 Hz to 2000 Hz Shock 6 ms | ≤ 150 m/s ² (EN 60068-2-6) ≤ 300 m/s ² (EN 60068-2-27) | |
| Operating temperature | 0 °C to 50 °C | |
| Protection EN 60529 | IP 53 when mounted according to the instructions | |
| Weight | 0.7 kg + 2 kg/m ML | |

* Please select when ordering

¹⁾ For position measurement

Please refer to the *General Electrical Information*—especially for connection to non-HEIDENHAIN electronics—at www.heidenhain.de/docu.

Interfaces

Incremental signals $\sim 1 V_{PP}$

HEIDENHAIN encoders with $\sim 1 V_{PP}$ interface provide voltage signals that can be highly interpolated.

The sinusoidal **incremental signals** A and B are phase-shifted by 90° elec. and have amplitudes of typically $1 V_{PP}$. The illustrated sequence of output signals—with B lagging A—applies for the direction of motion shown in the dimension drawing.

The **reference mark signal** R has a usable component G of approx. $0.5 V$. Next to the reference mark, the output signal can be reduced by up to $1.7 V$ to a quiescent value H. This must not cause the subsequent electronics to overdrive. Even at the lowered signal level, signal peaks with the amplitude G can also appear.

The data on **signal amplitude** apply when the power supply given in the specifications is connected to the encoder. They refer to a differential measurement at the 120 ohm terminating resistor between the associated outputs. The signal amplitude decreases with increasing frequency. The **cutoff frequency** indicates the scanning frequency at which a certain percentage of the original signal amplitude is maintained:

- $-3 \text{ dB} \triangleq 70\%$ of the signal amplitude
- $-6 \text{ dB} \triangleq 50\%$ of the signal amplitude

The data in the signal description apply to motions at up to 20% of the -3 dB -cutoff frequency.

Interpolation/resolution/measuring step

The output signals of the $1 V_{PP}$ interface are usually interpolated in the subsequent electronics in order to attain sufficiently high resolutions. For **velocity control**, interpolation factors are commonly over 1000 in order to receive usable information even at low rotational or linear velocities.

Measuring steps for **position measurement** are recommended in the specifications. For special applications, other resolutions are also possible.

Short-circuit stability

A temporary short circuit of one signal output to $0 V$ or U_P (except encoders with $U_{Pmin} = 3.6 V$) does not cause encoder failure, but it is not a permissible operating condition.

| Short circuit at | $20^\circ C$ | $125^\circ C$ |
|------------------|--------------|---------------|
| One output | < 3 min | < 1 min |
| All outputs | < 20 s | < 5 s |

| Interface | Sinusoidal voltage signals $\sim 1 V_{PP}$ |
|------------------------------|---|
| Incremental signals | 2 nearly sinusoidal signals A and B Signal amplitude M: 0.6 to $1.2 V_{PP}$; typically $1 V_{PP}$ Asymmetry $ P - N /2M$: ≤ 0.065 Amplitude ratio M_A/M_B : 0.8 to 1.25 Phase angle $ \varphi_1 + \varphi_2 /2$: $90^\circ \pm 10^\circ$ elec. |
| Reference-mark signal | One or several signal peaks R Usable component G: $\geq 0.2 V$ Quiescent value H: $\leq 1.7 V$ Switching threshold E, F: 0.04 to $0.68 V$ Zero crossovers K, L: $180^\circ \pm 90^\circ$ elec. |
| Connecting cables | Shielded HEIDENHAIN cable For example PUR $[4(2 \times 0.14 \text{ mm}^2) + (4 \times 0.5 \text{ mm}^2)]$ Max. 150 m at 90 pF/m distributed capacitance Propagation time 6 ns/m |

These values can be used for dimensioning of the subsequent electronics. Any limited tolerances in the encoders are listed in the specifications. For encoders without integral bearing, reduced tolerances are recommended for initial operation (see the mounting instructions).

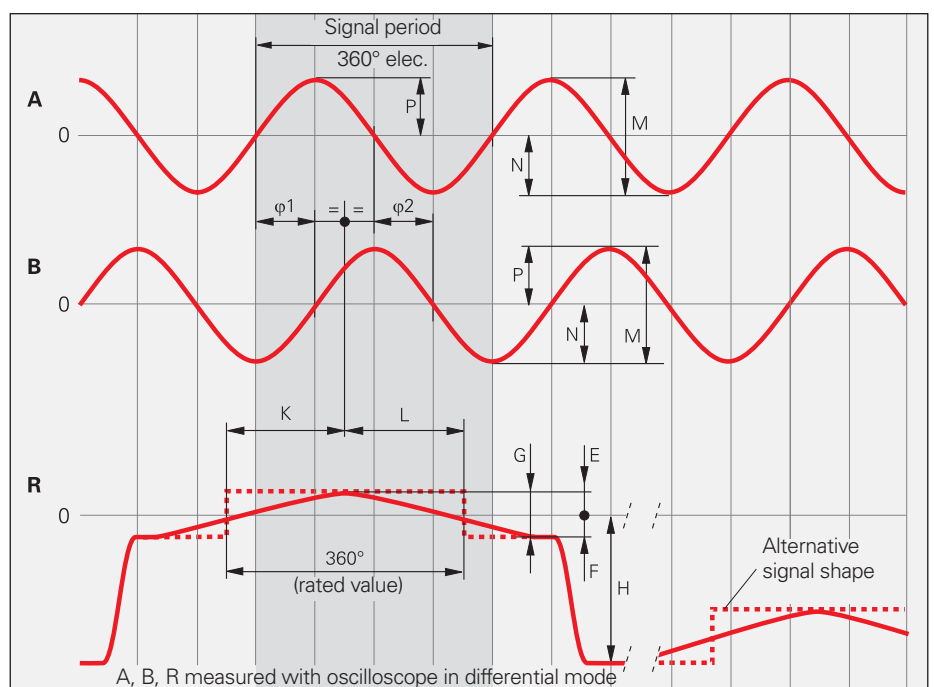

Cutoff frequency

Typical signal amplitude curve with respect to the scanning frequency (depends on encoder)

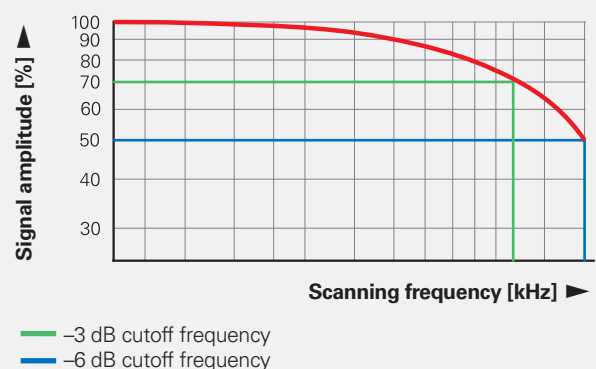

Input circuitry of subsequent electronics

Dimensioning

Operational amplifier MC 34074

$Z_0 = 120 \Omega$

$R_1 = 10 \text{ k}\Omega$ and $C_1 = 100 \text{ pF}$

$R_2 = 34.8 \text{ k}\Omega$ and $C_2 = 10 \text{ pF}$

$U_B = \pm 15 \text{ V}$

U_1 approx. U_0

-3 dB cutoff frequency of circuitry

Approx. 450 kHz

Approx. 50 kHz with $C_1 = 1000 \text{ pF}$
and $C_2 = 82 \text{ pF}$

The circuit variant for 50 kHz does reduce the bandwidth of the circuit, but in doing so it improves its noise immunity. Encoders with **higher signal frequencies** (e.g. LIP 281) require special input circuitry (see the *Exposed Linear Encoders* brochure).

Circuit output signals

$U_a = 3.48 \text{ V}_{PP}$ typically

Gain 3.48

Incremental signals Reference mark signal

$R_a < 100 \Omega$,
typically 24Ω
 $C_a < 50 \text{ pF}$
 $\Sigma I_a < 1 \text{ mA}$
 $U_0 = 2.5 \text{ V} \pm 0.5 \text{ V}$
(relative to 0 V of the
power supply)

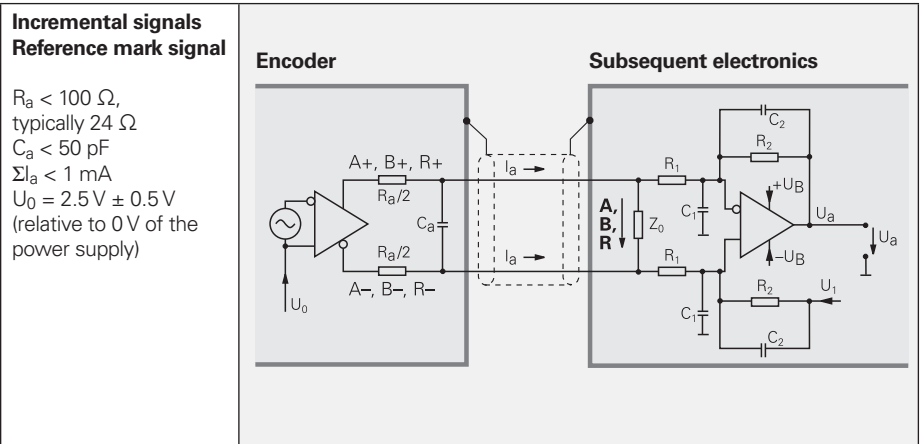

Monitoring of the incremental signals

The following thresholds are recommended for monitoring of the signal level M:

Lower threshold: 0.30 V_{PP}

Upper threshold: 1.35 V_{PP}

Pin layout for LS 388C, LS 688C

| 12-pin M23 coupling (male) | | | | 12-pin M23 connector (male) | | | | | | | | | |
|---------------------------------|-----------------|--------------|-----------------|-------------------------------|---------------------|-------|------|------|-----|-------|---------------|--------|--------|
| | | | | | | | | | | | | | |
| 15-pin D-sub connector (female) | | | | 15-pin D-sub connector (male) | | | | | | | | | |
| For ND 780, POSITIP, IK 220 | | | | For ND 28x | | | | | | | | | |
| | | | | | | | | | | | | | |
| | Power supply | | | | Incremental signals | | | | | | Other signals | | |
| | 12 | 2 | 10 | 11 | 5 | 6 | 8 | 1 | 3 | 4 | 9 | 7 | / |
| | 1 | 9 | 2 | 11 | 3 | 4 | 6 | 7 | 10 | 12 | 5/8/13/15 | 14 | - |
| | 4 | 12 | 2 | 10 | 1 | 9 | 3 | 11 | 14 | 7 | 5/6/8/15 | 13 | / |
| | Up | Sensor Up | 0V | Sensor 0V | A+ | A- | B+ | B- | R+ | R- | Vacant | Vacant | Vacant |
| | Brown/ Green | Blue | White/ Green | White | Brown | Green | Gray | Pink | Red | Black | / | Violet | Yellow |

Shield on housing; **Up** = power supply voltage

Sensor: The sensor line is connected internally with the corresponding power line.

Vacant pins or wires must not be used!

Interfaces

Incremental signals

HEIDENHAIN encoders with  interface incorporate electronics that digitize sinusoidal scanning signals with or without interpolation.

The **incremental signals** are transmitted as the square-wave pulse trains U_{a1} and U_{a2} , phase-shifted by 90° elec. The **reference mark signal** consists of one or more reference pulses U_{a0} , which are gated with the incremental signals. In addition, the integrated electronics produce their **inverted signals** $\overline{U_{a1}}$, $\overline{U_{a2}}$ and $\overline{U_{a0}}$ for noise-proof transmission. The illustrated sequence of output signals—with U_{a2} lagging U_{a1} —applies to the direction of motion shown in the dimension drawing.

The **fault-detection signal** $\overline{U_{aS}}$ indicates fault conditions such as breakage of the power line or failure of the light source. It can be used for such purposes as machine shut-off during automated production.

The distance between two successive edges of the incremental signals U_{a1} and U_{a2} through 1-fold, 2-fold or 4-fold evaluation is one **measuring step**.

The subsequent electronics must be designed to detect each edge of the square-wave pulse. The minimum **edge separation a** listed in the *Specifications* applies for the illustrated input circuitry with a cable length of 1 m, and refers to measurement at the output of the differential line receiver. Cable-dependent differences in the propagation times additionally reduce the edge separation by 0.2 ns per meter of cable. To prevent counting errors, design the subsequent electronics to process as little as 90 % of the resulting edge separation.

The max. permissible **shaft speed** or **traversing velocity** must never be exceeded.

The permissible **cable length** for transmission of the TTL square-wave signals to the subsequent electronics depends on the edge separation a . It is at most 100 m, or 50 m for the fault detection signal. This requires, however, that the power supply (see *Specifications*) be ensured at the encoder. The sensor lines can be used to measure the voltage at the encoder and, if required, correct it with an automatic control system (remote sense power supply).

| | |
|--|--|
| Interface | Square-wave signals  |
| Incremental signals | 2 square-wave signals U_{a1}, U_{a2} and their inverted signals $\overline{U_{a1}}$, $\overline{U_{a2}}$ |
| Reference mark signal Pulse width Delay time | 1 or more TTL square-wave pulses U_{a0} and their inverted pulses $\overline{U_{a0}}$ 90° elec. (other widths available on request) $ t_d \leq 50$ ns |
| Fault-detection signal Pulse width | 1 TTL square-wave pulse $\overline{U_{aS}}$ Improper function: LOW (upon request: U_{a1}/U_{a2} high impedance) Proper function: HIGH $t_s \geq 20$ ms |
| Signal amplitude | Differential line driver as per EIA standard RS-422 $U_H \geq 2.5$ V at $-I_H = 20$ mA ERN 1x23: 10 mA $U_L \leq 0.5$ V at $I_L = 20$ mA ERN 1x23: 10 mA |
| Permissible load | $Z_0 \geq 100 \Omega$ Between associated outputs $ I_L \leq 20$ mA Max. load per output (ERN 1x23: 10 mA) $C_{load} \leq 1000$ pF With respect to 0 V Outputs protected against short circuit to 0 V |
| Switching times (10 % to 90 %) | $t_r / t_f \leq 30$ ns (typically 10 ns) with 1 m cable and recommended input circuitry |
| Connecting cables Cable length Signal propagation | Shielded HEIDENHAIN cable For example PUR [4(2 × 0.14 mm ²) + (4 × 0.5 mm ²)] Max. 100 m ($\overline{U_{aS}}$ max. 50 m) at distributed capacitance 90 pF/m 6 ns/m |

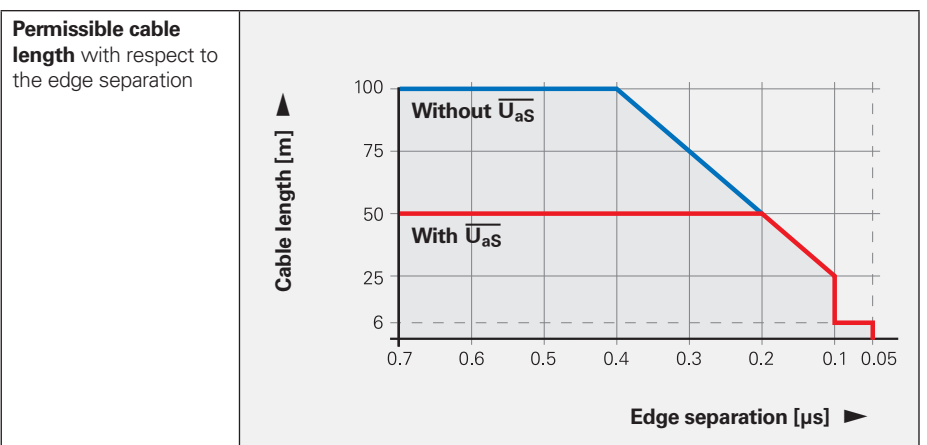
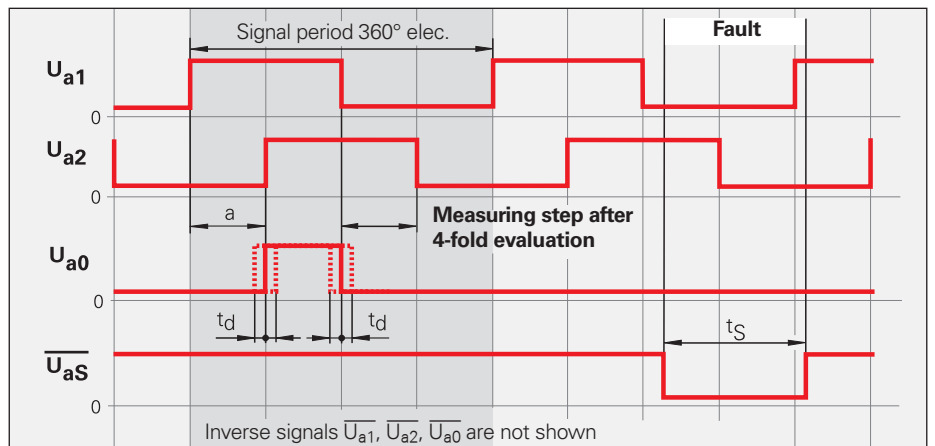

Input circuitry of subsequent electronics





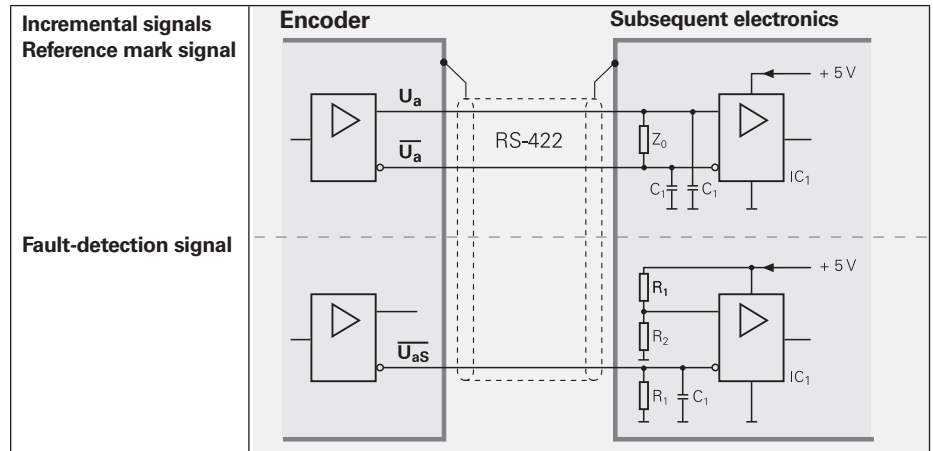

Dimensioning

IC₁ = Recommended differential line receiver
 DS 26 C 32 AT
 Only for a > 0.1 μs:
 AM 26 LS 32
 MC 3486
 SN 75 ALS 193

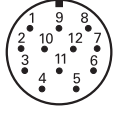
R₁ = 4.7 kΩ
 R₂ = 1.8 kΩ
 Z₀ = 120 Ω
 C₁ = 220 pF (serves to improve noise immunity)

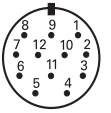
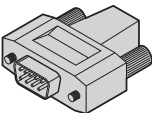
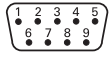

Pin layout for LS 328C, LS 628C

| | | | | | | | | | | | | | |
|--|-----------------|--------------------------|-----------------|---|---------------------|-----------------|-----------------|-----------------|-----------------|-----------------|-----------------|--------|--------|
| 12-pin M23 coupling, (male)   | | | | 12-pin M23 connector, (male)   | | | | | | | | | |
| 9-pin D-sub connector, (male) For ND 52x   | | | | | | | | | | | | | |
| | Power supply | | | | Incremental signals | | | | | | Other signals | | |
|  | 12 | 2 | 10 | 11 | 5 | 6 | 8 | 1 | 3 | 4 | 7 | / | 9 |
|  | 7 | / | 6 | / | 2 | 3 | 4 | 5 | 9 | 8 | / | 1 | / |
| | U _p | Sensor U _p | 0V | Sensor 0V | U _{a1} | U _{a1} | U _{a2} | U _{a2} | U _{a0} | U _{a0} | U _{aS} | Vacant | Vacant |
|  | Brown/ Green | Blue | White/ Green | White | Brown | Green | Gray | Pink | Red | Black | Violet | / | Yellow |

Cable shield connected to housing; **U_p** = Power supply voltage

Sensor: The sensor line is connected internally with the corresponding power line.

Vacant pins or wires must not be used!

Electrical connection

Connecting elements and cables

| Adapter cable | | LS 388C LS 688C | LS 328C LS 628C |
|--|--|--------------------|-------------------------|
| Adapter cable with M23 connector (male), 12-pin Extension cable Ø 6 mm | | 344228-xx | |
| Adapter cable in metal armor with M23 connector (male), 12-pin Extension cable Ø 10 mm | | 344451-xx | |
| With D-sub connector, (male), 15-pin Cable for ND 28x Ø 6 mm | | 387287-xx | – |
| Adapter cable with braiding with D-sub connector, (male), 9-pin Cable for ND 52x Ø 6 mm | | – | 617484-xx ¹⁾ |
| With D-sub connector, (female) 15-pin Cable for ND 780 and PT 880 Ø 6 mm | | 360974-xx | – |
| Armored adapter cable with D-sub connector, (female) 15-pin Cable for ND 780 and PT 880 Ø 10 mm | | 539878-xx | – |

Available cable lengths: 1 m/3 m/6 m/9 m

¹⁾ Max. cable length 6 m

| PUR connecting cable Ø 8 mm 12-pin: [4(2 x 0.14 mm ²) + (4 x 0.5 mm ²)] | | LS 388C LS 688C | LS 328C LS 628C |
|--|--|--------------------|--------------------|
| Complete For extension with M23 coupling (female) 12-pin and M23 connector (male), 12-pin | | 298400-xx | |
| Complete For ND 28x with M23 coupling (female), 12-pin and D-sub connector (male), 15-pin | | 309784-xx | |
| With one connector For ND 52x with M23 coupling (female), 12-pin and D-sub connector (male), 9-pin | | – | 617484-xx |
| Complete For ND 780, POSITIP 880 with M23 coupling (female), 12-pin and D-sub connector (male), 15-pin | | 309783-xx | – |
| With one connector With M23 coupling (female), 12-pin | | 298402-xx | |
| Cable only | | 244957-01 | |



HEIDENHAIN

DR. JOHANNES HEIDENHAIN GmbH

Dr.-Johannes-Heidenhain-Straße 5

83301 Traunreut, Germany

+49 8669 31-0

+49 8669 32-3132

E-mail: info@heidenhain.de

www.heidenhain.de

Vollständige und weitere Adressen siehe www.heidenhain.de
For complete and further addresses see www.heidenhain.de

| | | | | | |
|-----------|--|-----------|--|-----------|---|
| DE | HEIDENHAIN Vertrieb Deutschland 83301 Traunreut, Deutschland +49 8669 31-3132 +49 8669 32-3132 E-Mail: hd@heidenhain.de | DK | TPTEKNIK A/S 2670 Greve, Denmark www.tp-gruppen.dk | NO | HEIDENHAIN Scandinavia AB 7300 Orkanger, Norway www.heidenhain.no |
| | HEIDENHAIN Technisches Büro Nord 12681 Berlin, Deutschland +49 30 54705-240 | ES | FARRESA ELECTRONICA S.A. 08028 Barcelona, Spain www.farresa.es | PH | Machinebanks Corporation Quezon City, Philippines 1113 E-mail: info@machinebanks.com |
| | HEIDENHAIN Technisches Büro Mitte 08468 Heinsdorfergrund, Deutschland +49 03765 69544 | FI | HEIDENHAIN Scandinavia AB 02770 Espoo, Finland www.heidenhain.fi | PL | APS 02-384 Warszawa, Poland www.heidenhain.pl |
| | HEIDENHAIN Technisches Büro West 44379 Dortmund, Deutschland +49 0231 618083-0 | FR | HEIDENHAIN FRANCE sarl 92310 Sèvres, France www.heidenhain.fr | PT | FARRESA ELECTRÓNICA, LDA. 4470 - 177 Maia, Portugal www.farresa.pt |
| | HEIDENHAIN Technisches Büro Südwest 70771 Leinfelden-Echterdingen, Deutschland +49 0711 993395-0 | GB | HEIDENHAIN (G.B.) Limited Burgess Hill RH15 9RD, United Kingdom www.heidenhain.co.uk | RO | HEIDENHAIN Reprezentanță Romania Braşov, 500407, Romania www.heidenhain.ro |
| | HEIDENHAIN Technisches Büro Südost 83301 Traunreut, Deutschland +49 08669 31-1345 | GR | MB Milionis Vassilis 17341 Athens, Greece www.heidenhain.gr | RS | Serbia → BG |
| | | HK | HEIDENHAIN LTD Kowloon, Hong Kong E-mail: sales@heidenhain.com.hk | RU | OOO HEIDENHAIN 125315 Moscow, Russia www.heidenhain.ru |
| AR | NAKASE SRL. B1653AOX Villa Ballester, Argentina www.heidenhain.com.ar | HR | Croatia → SL | SE | HEIDENHAIN Scandinavia AB 12739 Skärholmen, Sweden www.heidenhain.se |
| AT | HEIDENHAIN Techn. Büro Österreich 83301 Traunreut, Germany www.heidenhain.de | HU | HEIDENHAIN Kereskedelmi Képviselet 1239 Budapest, Hungary www.heidenhain.hu | SG | HEIDENHAIN PACIFIC PTE LTD. Singapore 408593 www.heidenhain.com.sg |
| AU | FCR Motion Technology Pty. Ltd Laverton North 3026, Australia E-mail: vicsales@fcrmotion.com | ID | PT Servitama Era Toolsindo Jakarta 13930, Indonesia E-mail: ptset@group.gts.co.id | SK | KOPRETINA TN s.r.o. 91101 Trenčín, Slovakia www.kopretina.sk |
| BA | Bosnia and Herzegovina → SL | IL | NEUMO VARGUS MARKETING LTD. Tel Aviv 61570, Israel E-mail: neumo@neumo-vargus.co.il | SL | Posredništvo HEIDENHAIN NAVO d.o.o. 2000 Maribor, Slovenia www.heidenhain-hubl.si |
| BE | HEIDENHAIN NV/SA 1760 Roosdaal, Belgium www.heidenhain.be | IN | HEIDENHAIN Optics & Electronics India Private Limited Chetpet, Chennai 600 031, India www.heidenhain.in | TH | HEIDENHAIN (THAILAND) LTD Bangkok 10250, Thailand www.heidenhain.co.th |
| BG | ESD Bulgaria Ltd. Sofia 1172, Bulgaria www.esd.bg | IT | HEIDENHAIN ITALIANA S.r.l. 20128 Milano, Italy www.heidenhain.it | TR | T&M Mühendislik San. ve Tic. LTD. ŞTİ. 34728 Ümraniye-Istanbul, Turkey www.heidenhain.com.tr |
| BR | DIADUR Indústria e Comércio Ltda. 04763-070 – São Paulo – SP, Brazil www.heidenhain.com.br | JP | HEIDENHAIN K.K. Tokyo 102-0083, Japan www.heidenhain.co.jp | TW | HEIDENHAIN Co., Ltd. Taichung 40768, Taiwan R.O.C. www.heidenhain.com.tw |
| BY | Belarus GERTNER Service GmbH 50354 Huerth, Germany www.gertnergroup.com | KR | HEIDENHAIN Korea LTD. Gasan-Dong, Seoul, Korea 153-782 www.heidenhain.co.kr | UA | Gertner Service GmbH Büro Kiev 01133 Kiev, Ukraine www.gertnergroup.com |
| CA | HEIDENHAIN CORPORATION Mississauga, Ontario L5T2N2, Canada www.heidenhain.com | ME | Montenegro → SL | US | HEIDENHAIN CORPORATION Schaumburg, IL 60173-5337, USA www.heidenhain.com |
| CH | HEIDENHAIN (SCHWEIZ) AG 8603 Schwerzenbach, Switzerland www.heidenhain.ch | MK | Macedonia → BG | VE | Maquinaria Diekmann S.A. Caracas, 1040-A, Venezuela E-mail: purchase@diekmann.com.ve |
| CN | DR. JOHANNES HEIDENHAIN (CHINA) Co., Ltd. Beijing 101312, China www.heidenhain.com.cn | MX | HEIDENHAIN CORPORATION MEXICO 20235 Aguascalientes, Ags., Mexico E-mail: info@heidenhain.com | VN | AMS Co. Ltd HCM City, Vietnam E-mail: davidgoh@amsvn.com |
| CZ | HEIDENHAIN s.r.o. 102 00 Praha 10, Czech Republic www.heidenhain.cz | MY | ISOSERVE Sdn. Bhd 56100 Kuala Lumpur, Malaysia E-mail: isoserve@po.jaring.my | VN | AMS Co. Ltd HCM City, Vietnam E-mail: davidgoh@amsvn.com |
| | | NL | HEIDENHAIN NEDERLAND B.V. 6716 BM Ede, Netherlands www.heidenhain.nl | ZA | MAFEMA SALES SERVICES C.C. Midrand 1685, South Africa www.heidenhain.co.za |

Zum Abheften hier falzen! / Fold here for filing!

