



HEIDENHAIN



Digital Readouts For Metrology Applications

May 2012

For many metrology applications, ranging from simple measuring stations to complex inspection systems with multiple measuring points, HEIDENHAIN supports you with the appropriate digital readouts or PC solutions.

The functionality always orients itself to the specific application. Whether it is an SPC inspection station, a tool presetter, a profile projector, a measuring microscope, or a manual coordinate measuring machine, the **digital readouts and PC solutions for metrology applications** from HEIDENHAIN are the right choice for measurement tasks. There is even a CNC option for the automation of measurement tasks.

Digital readouts from HEIDENHAIN for manual machine tools optimally support the operator with well proven cycles for milling, drilling and turning. You can find these digital readouts on the Internet at www.heidenhain.de or in the *Digital Readouts and Linear Encoders for Manually Operated Machine Tools* product brochure.



Digital readouts and PC solutions for metrology applications

Contents

Overview		
	Selection guide for 2-D and 3-D measuring tasks	4
	Selection guide for measuring and testing tasks	6
Specifications		
	ND 100 QUADRA-CHEK – for simple 2-D geometries	8
	ND 1100 QUADRA-CHEK – for simple positioning tasks	10
	ND 1200 QUADRA-CHEK – for 2-D geometries	12
	ND 1300 QUADRA-CHEK – for convenient 2-D measurement	14
	ND 1400 QUADRA-CHEK – for manual 3-D measuring machines	16
	IK 5000 QUADRA-CHEK – universal PC package solution	18
	ND 1200T TOOL-CHEK – for tool presetters	22
	ND 2100 G GAGE-CHEK – for multipoint inspection apparatuses	24
	ND 200 – for measuring and testing stations	26
Mounting		
	Dimensions	28
	Mounting	30
Accessories		
	Calibration and demonstration parts	32
	External control elements	33
	Optical edge detector	34
	Servo amplifiers	35
Electrical connection		
Interfaces	Overview	36
	Encoder connections	38
	Switching inputs/outputs ND 287	40
Software	QUADRA-CHEK Wedge	42

Selection guide

2-D and 3-D measuring tasks

	Display	Axes		Functions
		Length	Angle	
ND 100 QUADRA-CHEK <ul style="list-style-type: none"> • Profile projectors • Measuring microscopes 	Monochrome	2 (XY)	–	<ul style="list-style-type: none"> • Measurement of 2-D features • Point measurement with crosshairs • Graphic display of measurement results
		2 (XY)	1 (Q)	
		3 (XYZ)	–	
ND 1100 QUADRA-CHEK <ul style="list-style-type: none"> • Positioning equipment • Measuring fixtures • Manual coordinate measuring machines 	Monochrome	2 (adjustable)		Measurement series with min./max. value storage
		3 (adjustable)		
		4 (adjustable)		
ND 1200 QUADRA-CHEK <ul style="list-style-type: none"> • Profile projectors • Measuring microscopes • 2-D measuring machines 	Monochrome	2 (XY)	–	<ul style="list-style-type: none"> • Measurement of 2-D features • Measure Magic function • Point measurement with crosshairs • Programming of features and parts • Graphic display of measurement results
		2 (XY)	1 (Q)	
		3 (XYZ)	–	
		3 (XYZ)	1 (Q)	
ND 1300 QUADRA-CHEK <ul style="list-style-type: none"> • Profile projectors • Measuring microscopes • Video measuring machines 	Color touch-screen	2 (XY)	–	<ul style="list-style-type: none"> • Measurement of 2-D features • Measure Magic function • Point measurement with crosshairs • Programming of features and parts • Graphic display of measurement results
		2 (XY)	1 (Q)	
		3 (XYZ)	–	
		3 (XYZ)	1 (Q)	
ND 1400 QUADRA-CHEK <ul style="list-style-type: none"> • Manual coordinate measuring machines 	Color touch-screen	3 (XYZ)	1 (Q)	<ul style="list-style-type: none"> • Measurement of 2-D and 3-D features • Points measured via touch probe, crosshairs or rigid probing element • Measure Magic function • Programming of features and parts • Graphic display of measurement results • Five coordinate systems can be stored • Touch-probe management
IK 5000 QUADRA-CHEK Universal PC package solution for <ul style="list-style-type: none"> • Profile projectors • Measuring microscopes • Video measuring machines • Coordinate measuring machines 	PC screen	3 (XYZ)	1 (Q)	<ul style="list-style-type: none"> • Measurement of 2-D and 3-D features (depending on the version) • Point measurement with crosshairs • Programming of features and parts • Graphic display of measurement results • Entry of tolerances • Import of CAD drawings for direct comparison • 3-D profiling (option; only with touch probe)
		3 (XYZ)	–	
		3 (XYZ)	1 (Q)	
		3 (XYZ)	1 (Q)	
		3 (XYZ)	–	
		3 (XYZ)	1 (Q)	
		3 (XYZ)	1 (Q)	
		3 (XYZ)	1 (Q)	

Options/Additional functions	Model	Page
–	ND 122	8
	ND 123	
Touch probe	ND 1102	10
	ND 1103	
	ND 1104	
Optical edge detector	ND 1202	12
	ND 1203	
Optical edge finder upon request	ND 1204	
<ul style="list-style-type: none"> • Optical edge detector • Video edge detection and live image display • Archiving and output of live images • Zoom and light control, programmable • NC axis control and autofocus 	ND 1302	14
	ND 1303	
	ND 1304	
–	ND 1404	16

–	IK 5294	18
3-D; touch probe	IK 5293	
Optical edge finder	IK 5394-EG	
3-D; zoom and light control; video evaluation; touch probe	IK 5394-3D	
CNC; optical edge detector	IK 5493	
CNC; video evaluation; zoom and light control; autofocus	IK 5494-2D	
CNC; 3-D; video evaluation; touch probe; zoom and light control; autofocus	IK 5494-3D	
CNC; 3-D; video evaluation; TP 200 touch probe; zoom and light control; autofocus	IK 5594	



ND 100 QUADRA-CHEK



ND 1100 QUADRA-CHEK



ND 1200 QUADRA-CHEK



ND 1300 QUADRA-CHEK



IK 5000 QUADRA-CHEK

Selection guide

Measuring and testing tasks

	Display	Axes		Functions
		Length	Angle	
ND 1200T TOOL-CHEK <ul style="list-style-type: none"> • Tool presetters 	Monochrome	2 (XY)	–	<ul style="list-style-type: none"> • Point measurement with crosshairs • 99 tool adapters and 300 tools
ND 2100G GAGE-CHEK <ul style="list-style-type: none"> • Multipoint inspection apparatuses • SPC inspection stations 	Color	4 (adjustable)		<ul style="list-style-type: none"> • Programming of up to 100 parts • Graphic display of measurement results • Sorting and tolerance checking using tolerance and warning limits • Measurement series with min./max. value storage • Entry of formulas and combinations • Functions for statistical process control (SPC)
		8 (adjustable)		
ND 200 <ul style="list-style-type: none"> • Measuring fixtures • Adjustment and inspection equipment • SPC inspection stations 	Monochrome	1 (adjustable)	–	<ul style="list-style-type: none"> • Metrology and statistical functions (sorting and tolerance checking, measurement series, SPC)
	Color	Up to 2 (adjustable)		
MSE 1000 Modular electronics for <ul style="list-style-type: none"> • Multipoint inspection apparatuses • SPC inspection stations 	PC screen	Up to 250 (adjustable)		<ul style="list-style-type: none"> • Modular design • Configurable as desired • Various interfaces • Fast communication with higher-level computer systems • Universal outputs



Options/Additional functions	Model	Page
–	ND 1202T	22
–	ND 2104 G ND 2108 G	24
–	ND 280	26
Second encoder for sum/difference display, temperature compensation	ND 287	
–	MSE 1000	<i>MSE 1000</i> Product Information



ND 2100 G GAGE-CHEK

ND 1200T



ND 200



MSE 1000

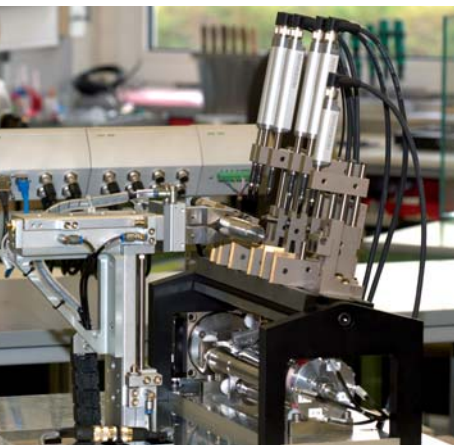

ND 100 QUADRA-CHEK

– the digital readouts for 2-D geometries

The ND 100 digital readouts can support two to three axes, and function as measuring computers for 2-D geometries. They are suited as entry-level readouts for optical comparators, measuring microscopes and 2-D measuring machines.

Description

The ND 100 digital readouts have a monochrome flat-panel screen for displayed values, dialogs and inputs, graphics functions and soft keys. With its sturdy housing and splash-proof membrane keyboard, the ND 100 is built for the workshop.

Functions

The appropriate combination of defined function keys and context-dependent soft keys always provides you with a clear overview. The innovative operator guidance provides self-explanatory information about the various functions. It already supports you while setting up the coordinate system (aligning the part and specifying the datum).

Predefined features (point, line, circle) are available for measurement. You can also apply tolerance values to features and relationships. Only those tolerances actually possible are offered for the selected feature.

The ND 100 readouts measure points on plane (2-D) contours manually via crosshairs.

Data interfaces

A USB interface enables the digital readout to indicate measured values and import or export parameters and tables.

Graphic display

In addition to the position values, the ND 100 also displays the features graphically. Along with the individual measuring points, the geometrical and arithmetical deviations are also shown. Furthermore, for circles the maximum inscribed circles and minimum circumscribed circles are shown.

Tolerances

You can also apply tolerance values to any feature. Only those tolerances actually possible are offered for the selected feature. This means that a point can only be assigned a tolerance check for its position, whereas a circle can be assigned position, shape and size tolerances.

Defining features

You can use the QUADRA-CHEK digital readouts to define features yourself. For example, this could be a circle whose position and dimensions are exactly defined, or an alignment line that is at a specified angle to a measurable line.

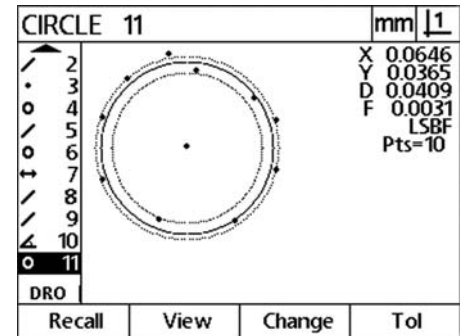
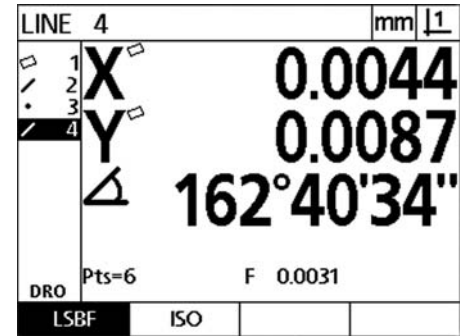



	ND 122	ND 123
Axes	2 (XY)	3 (XYZ or XYQ, configurable)
Encoder inputs	□□TTL	
Display step¹⁾	<i>Linear axis:</i> 1 mm to 0.0001 mm <i>Angular axis:</i> 1° to 0.0001° (00° 00' 01")	
Display	5.7" monochrome flat-panel display for position values, dialogs and inputs, graphics functions and soft keys	
Functions	<ul style="list-style-type: none"> • Measurement of two-dimensional features (2-D) • Point measurement with crosshairs • Graphic display of measurement results • Entry of tolerances • Measurement series with min./max. value storage 	
Error compensation	<ul style="list-style-type: none"> • Linear, and segmented linear over up to 150 points • Squareness calibration • Matrix compensation over up to 30 x 30 points 	
Data interface	<ul style="list-style-type: none"> • USB (type B) 	
Accessories	Tilting base, mounting arm	
Main power input	100 V to 240 V AC (-15 % to +10 %), 48 Hz to 62 Hz	
Operating temperature	0 °C to 45 °C	
Protection EN 60529	IP 40, front panel IP 54	
Mounting	Tilting base or mounting arm (accessories)	
Weight	Approx. 2.6 kg	

¹⁾ Depends on the signal period of the connected encoder as well as the subdivision factor

ND 1100 QUADRA-CHEK

– the digital readouts for simple positioning tasks

The ND 1100 QUADRA-CHEK digital readouts can support up to four axes. They are mainly suited to positioning tasks on positioning equipment and measuring fixtures, as well as for retrofitting on measuring machines for data acquisition and relaying to a PC.

Description

The ND 1100 QUADRA-CHEK digital readouts have a monochrome flat-panel screen for displayed values, dialogs, inputs and soft keys. The robust, die-cast aluminum enclosure meets the demands of metrology and production control.

Functions

The logical placement of the function keys and soft keys permits innovative operator guidance, which supports you when using the diverse functions.

Along with the usual functions of a digital readout, such as zeroing and setting of reference values, the ND 1100 QUADRA-CHEK units have numerous more useful functions:

- Each axis can be configured for linear or angular display
- Minimum/maximum value storage
- Simple switching between counting directions
- Continuous data output via internal clock, or upon probing

Data interfaces

You use the data interfaces to output measured points as well as to save settings and compensation values. The ND 1100 has an RS-232-C/V.24 serial interface for communication with a PC. You can connect printers or memory media directly to the USB port.

Display format

Depending on the type of encoder connected, you can define linear or angular display individually for each axis.

X	14.5653		
Y	-8.2776		
Z	20°30'50"		
Q	324°55'30"		
Abs	MM	Menu	Preset

Minimum/maximum value storage

The ND 1100 is capable of minimum/maximum value storage in any selectable axis. The largest and smallest measured values of a measurement series, as well as the difference, are stored, and can be output via the data interface. This function is especially advantageous during concentricity testing.

MinMax	14.7653			
Max	14.5653			
Min	0.2000			
Spannw.				
X				
Both	Max	Min	Neu	Preset

Touch-probe connection

Touch probes (e. g. from HEIDENHAIN or Renishaw) can be connected to the ND 1100. The digital readout automatically reads the current position value during probing, and also takes the radius of the stylus into account.

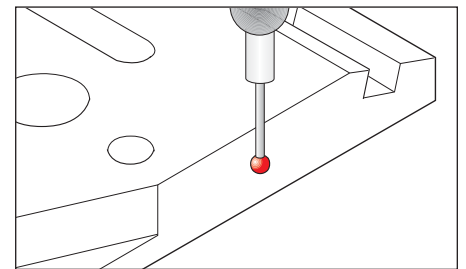

Output format of measured values

Since the universal output formats are used by various manufacturers of measuring machines, the ND 1100 can easily be retrofitted as a data logger to manually operated measuring machines. The measured values are captured by the ND, and then relayed to a connected PC for further processing.

X	12.3553 mm
Y	-8.2006 mm
Z	20.30.50 dms
Q	326.37.30 dms



	ND 1102	ND 1103	ND 1104
Axes	2	3	4
Encoder inputs*	~ 1 V _{PP} or □□TTL (other interfaces upon request)		
Subdivision factor	10-fold (only for 1 V _{PP})		
Display step¹⁾	Adjustable, max. 7 digits Linear axis: 1 mm to 0.0001 mm Angular axis: 1° to 0.0001° (00° 00' 01")		
Display	5.7" monochrome flat-panel display for position values, dialogs and inputs, and soft keys		
Functions	<ul style="list-style-type: none"> • Measurement series with min./max. value storage • Difference between minimum and maximum (range) • Scaling factor 		
Error compensation	<ul style="list-style-type: none"> • Linear, and segmented linear over up to 300 points • Squareness calibration 		
Data interface	<ul style="list-style-type: none"> • RS-232-C/V.24 • USB (type A) 		
Touch-probe connection*	HEIDENHAIN touch probe or Renishaw touch probe		
Other connections	Foot switch for two functions, or remote keypad		
Accessories	Foot switch, remote keypad, protective cover		
Main power input	100 V to 240 V AC (-15 % to +10 %), 43 Hz to 63 Hz		
Operating temperature	0 °C to 45 °C		
Protection EN 60529	IP 00, front panel IP 40		
Mounting*	Tilting base or mounting base		
Weight	ND with tilting base: approx. 4.8 kg; ND with mounting base: approx. 2 kg		

* Please select when ordering

¹⁾ Depends on the signal period of the connected encoder as well as the subdivision factor

ND 1200 QUADRA-CHEK

– the digital readouts for 2-D geometries

The ND 1200 digital readouts can support up to four axes, and function as measuring computers for 2-D geometries. They are mainly suited to optical comparators, measuring microscopes and 2-D measuring machines.

Description

The ND 1200 QUADRA-CHEK digital readouts have a monochrome flat-panel screen for displayed values, dialogs and inputs, graphics functions and soft keys. The robust, die-cast aluminum enclosure meets the demands of metrology and production control.

Functions

The appropriate combination of defined function keys and context-dependent soft keys always provides you with a clear overview. The innovative operator guidance provides self-explanatory information about the various functions. It already supports you while setting up the coordinate system (aligning the part and specifying the datum).

Predefined features (point, line, circle) are available for measurement. The "Measure Magic" function makes measurement especially easy: it selects that feature which best matches the shape implied by the points probed. In addition, you can establish relationships (distances, angles) between features.

You can also apply tolerance values to features and relationships. Only those tolerances actually possible are offered for the selected feature. This means that a point can only be assigned a tolerance check for its position, whereas a circle can be assigned position, shape and size tolerances.

The ND 1200 captures measuring points of plane contours (2-D) either manually via crosshairs or, as an option, automatically via the optical edge detector.

Data interfaces

You use the data interfaces to output measuring points as well as to read and transmit settings, compensation values and programs. The RS-232-C/V.24 serial interface enables communication with a PC. You can connect printers or memory media to the USB port.

Graphic display

In addition to the position values, the ND 1200 also displays the features graphically. Along with the individual measuring points, the geometrical and arithmetical deviations are also shown. Furthermore, for circles the maximum inscribed circles and minimum circumscribed circles are shown.

CIRCLE 5		mm	1	+
X	-78.9149			
Y	3.9592			
D	0.3898			
Pts=8				
F	0.0190			
LSBF				
DRO				
Recall	View	Change	Zoom	Tol

Tolerances

You can also apply tolerance values to any feature. Only those tolerances actually possible are offered for the selected feature. This means that a point can only be assigned a tolerance check for its position, whereas a circle can be assigned position, shape and size tolerances.

CIRCLE 2		mm	1	+
Circle Position and Size Tolerance				
Tol Type: BiDir				
	Actual	Dev		
X	174.9079	0.0079		✓
Y	-20.1577	0.0023		✓
D	58.3624	0.0004		✓
Edit	Nominal	Actual	Dev	Other

Defining features

You can use the QUADRA-CHEK digital readouts to define features yourself. For example, this could be a circle whose position and dimensions are exactly defined, or an alignment line that is at a specified angle to a measurable line.

ANGLE 12		mm	1	+
X	10.0000			
Y	20.0000			
A1	50°00'00"			
Created				
DRO				
Recall	View			Tol

Measure Magic

The Measure Magic function recognizes the geometric pattern based on the distribution of the measuring points, and automatically calculates which feature it is, such as a point, line or circle.

If the measuring points are poorly chosen, then it may not be possible to determine the feature unambiguously. Measure Magic then chooses the more common version. You can have the feature displayed graphically, and then select from the possibilities.

CIRCLE 2		mm	1	+
X	221.6924			
Y	9.0327			
D	8.6658			
Pts=3				
F	0.0000			
LSBF				
DRO				
Recall	View	Change	Zoom	Tol



	ND 1202	ND 1203	ND 1204
Axes*	2 (XY)	3 (XYQ) or 3 (XYZ)	4 (XYZQ)
Encoder inputs*	~ 1 V _{PP} or □□TTL (other interfaces upon request)		
Subdivision factor	10-fold (only for 1 V _{PP})		
Display step¹⁾	Adjustable, max. 7 digits Linear axes XYZ: 1 mm to 0.0001 mm Angular axis Q: 1° to 0.0001° (00° 00' 01")		
Display	5.7" monochrome flat-panel display for position values, dialogs and inputs, graphics functions and soft keys		
Functions	<ul style="list-style-type: none"> • Measurement of two-dimensional features (2-D) • Point measurement with crosshairs • Programming of features and parts • Measure Magic: automatic recognition of geometries • Graphic display of measurement results • Entry of tolerances • Measurement series with min./max. value storage 		
Edge detector*	Automatic point measurement via optical edge detector (option)	Upon request	
Error compensation	<ul style="list-style-type: none"> • Linear, and segmented linear over up to 150 points • Squareness calibration • Matrix compensation over up to 30 x 30 points 		
Data interface	<ul style="list-style-type: none"> • RS-232-C/V.24 • USB (type A) 		
Other connections	<ul style="list-style-type: none"> • Foot switch for two functions, or remote keypad • Optical edge detector (only if the option is selected) 		
Accessories	Foot switch, remote keypad, fiber-optic cables, holder, demo part, protective cover		
Main power input	100 V to 240 V AC (-15 % to +10 %), 43 Hz to 63 Hz		
Operating temperature	0 °C to 45 °C		
Protection EN 60529	IP 00, front panel IP 40		
Mounting*	Tilting base or mounting base		
Weight	ND with tilting base: approx. 4.8 kg; ND with mounting base: approx. 2 kg		

* Please select when ordering

¹⁾ Depends on the signal period of the connected encoder as well as the subdivision factor

ND 1300 QUADRA-CHEK

– the digital readouts for convenient 2-D measurement

The ND 1300 QUADRA-CHEK digital readouts can support up to four axes. They function as measuring computers with 2-D measurement of points, suiting them for measuring microscopes, measuring projectors and profile projectors, as well as for video measuring machines if the video edge detection option is installed.

Description

The digital readouts of the ND 1300 series are characterized by the large, color touchscreen. Their enclosures consist of robust, die-cast aluminum.

Functions

The innovative operator guidance provides self-explanatory information about the various functions. It already supports you while setting up the coordinate system (aligning the part and specifying the datum).

Predefined features (point, line, circle, slot and rectangle) are available for measurement. The "Measure Magic" function makes measurement especially easy. In addition, you can establish relationships (distances, angles) between features.

You can create or automatically record measuring programs for repeated parts. The digital readout graphically takes you to the next measuring position during program run.

Depending on the option installed, the ND 1300 probes the points of plane (2-D) contours either automatically or manually via crosshairs, optical edge detection, or a video camera. The integrated image processing function of the video option provides a special benefit: the video image is shown on the screen in real time, and can be saved and output via the data interface. The digital readout even assumes complete control of the illumination and the motor zoom.

Data interfaces

You use the data interfaces to output measuring points as well as to read and transmit settings, compensation values and programs. The RS-232-C/V.24 serial interface enables communication with a PC. You can connect printers or memory media to the USB port.

Clearly structured display

The large, color, flat-panel touchscreen enables simple operation with intuitive operator guidance, since in each mode only those functions actually available are offered for selection. The numeric keypad and the few basic function keys are located in ergonomically favorable positions.

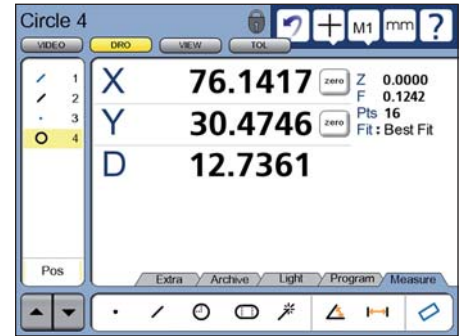

Point measurement

The ND 1300 readouts are designed for 2-D measurements. You are provided with various tools with which you can manually or automatically measure points. For automatic point measurement you simply roughly approach the position. The actual edge is automatically detected by the active tool (option). This objective point measurement permits a high degree of repeatability. This makes it possible for you to work quickly and reliably, without tiring, while at the same time maintaining a low degree of measurement uncertainty.

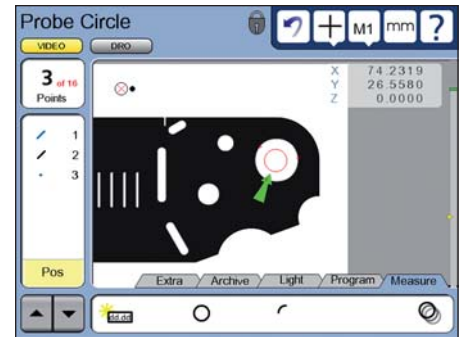

Integrated image processing

The ND 1300 with video option optimally combines in one unit the functions of a position display unit with the capability of displaying the image of the measured object directly on the screen. The separate PC with a frame grabber or monitor with crosshair generator that you would normally need is not necessary. Video cameras with S-Video or composite interfaces can be connected.

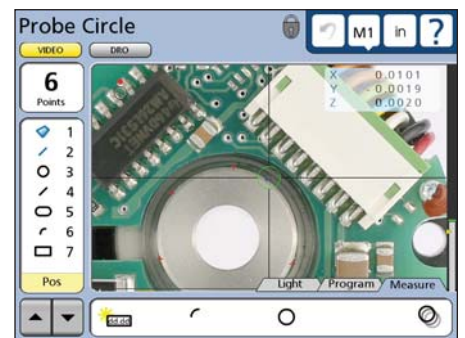

Axis positioning

The CNC option lets the ND 1300 work as a full-fledged control, directly controlling the positioning of the X, Y, Z and Q axes. Servo motors and stepper motors can be connected. The necessary servo amplifiers for two or three axes are available as accessories.

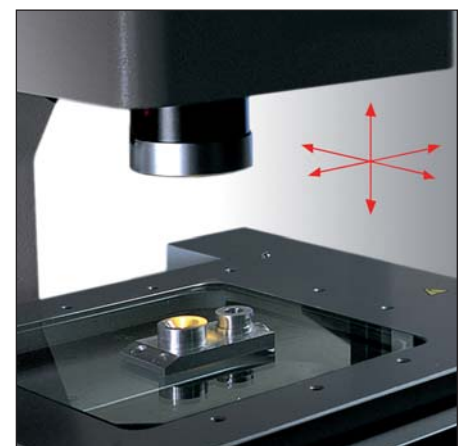



	ND 1302	ND 1303	ND 1304
Axes*	2 (XY)	3 (XYQ) or 3 (XYZ)	4 (XYZQ)
Encoder inputs*	~ 1 V _{PP} or □□ TTL (other interfaces upon request)		
Subdivision factor	10-fold (only for 1 V _{PP})		
Display step¹⁾	Adjustable, max. 7 digits <i>Linear axes XYZ: 1 mm to 0.0001 mm; Angular axis Q: 1° to 0.0001° (00° 00' 01")</i>		
Display	8.4" color flat-panel display (touchscreen); resolution: SVGA 800 x 600 pixels, for position values, dialogs and inputs, graphics functions, soft keys, and display of video images with the <i>Video</i> option		
Functions	<ul style="list-style-type: none"> • Measurement of two-dimensional features (2-D) • Point measurement with crosshairs • Programming of features and parts • Measure Magic: automatic recognition of geometries • Graphic display of measurement results • Entry of tolerances 		
Edge detector* (option)	<ul style="list-style-type: none"> • Automatic point measurement via optical edge detector 		
Video* (option)	<ul style="list-style-type: none"> • Automatic point measurement via video edge detection • Manual autofocus (only for Z axis) • Show live images • Archive and output live images (<i>Archive</i> option, only with the <i>Video</i> and <i>Zoom</i> options) • Zoom and light control, programmable (<i>Zoom</i> option, only with the <i>Video</i> and <i>CNC</i> options) 		
CNC* (option)	<ul style="list-style-type: none"> • Automation of measurement tasks • Axis control (for XYZQ) for servo and stepper motors • Autofocus via stepper-motor control 		
Error compensation	<ul style="list-style-type: none"> • Linear, and segmented linear over up to 1000 points • Squareness calibration; matrix compensation over up to 30 x 30 points 		
Data interface	RS-232-C/V.24; USB (type A)		
Other connections	<ul style="list-style-type: none"> • Foot switch for two functions, or remote keypad • Video connection for S-Video and composite (<i>Video</i> option) • Light control over six light sources and zoom control (for <i>Video</i> and <i>Zoom</i> options) • CNC outputs and inputs for joystick (for <i>CNC</i> option) 		
Accessories	Foot switch, remote keypad, fiber-optic cables, holder, servo amplifier, calibration standard, demo parts, protective cover		
Main power input	100 V to 240 V AC (-15 % to +10 %), 43 Hz to 63 Hz		
Operating temperature	0 °C to 45 °C		
Protection EN 60529	IP 00, front panel IP 40		
Mounting*	Tilting base or mounting base		
Weight	<i>ND with tilting base: approx. 4.8 kg; ND with mounting base: approx. 2 kg</i>		

* Please select when ordering; the options *Edge detector* and *Video* cannot be combined

¹⁾ Depends on the signal period of the connected encoder as well as the subdivision factor

ND 1400 QUADRA-CHEK

– the digital readout for manual 3-D measuring machines

The ND 1400 QUADRA-CHEK digital readout supports four axes: in addition to the linear axes XYZ it features an auxiliary axis Q solely for angular display. The readout is designed specifically for manual coordinate measuring machines, and can capture two- and three-dimensional features with its measuring computer functionality.

Description

The ND 1400 digital readout is characterized by the large, color touchscreen. Their enclosures consist of robust, die-cast aluminum.

Functions

The innovative operator guidance provides self-explanatory information about the various functions. It already supports you while setting up the coordinate system (ascertaining the reference plane, aligning the part and specifying the datum).

Predefined features (point, line, circle, slot, rectangle, plane, cylinder, cone, sphere) are available for measurement. The "Measure Magic" function makes measurement especially easy: it selects that feature which best matches the shape implied by the points probed. In addition, you can establish relationships (distances, angles) between all features.

You can create or automatically record measuring programs for repeated parts. The digital readout graphically takes you to the next measuring position during program run.

You can also use the ND 1400 to measure 3-D features, such as surfaces, cylinders, cones, etc. The measuring points are probed with a touch probe. If a triggering touch probe is used the values are transferred automatically. With rigid probing elements a key must be pressed. The measured features can be clearly displayed either in three dimensions or in one of the three projection planes.

Data interfaces

You use the data interfaces to output measuring points as well as to read and transmit settings, compensation values and programs. The RS-232-C/V.24 serial interface enables communication with a PC. You can connect printers or memory media to the USB port.

Clearly structured display

The large, color, flat-panel touchscreen enables simple operation with intuitive operator guidance, since in each mode only those functions actually available are offered for selection. The numeric keypad and the few basic function keys are located in ergonomically favorable positions.

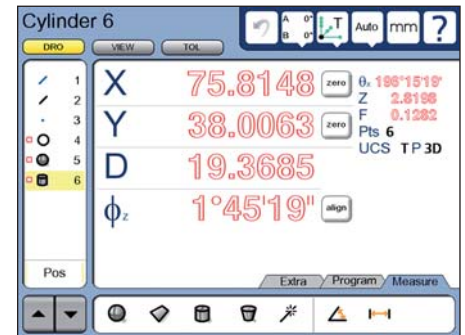

Measuring 3-D contours

In addition to the flat geometric features, such as points, lines, circles, etc., you can also use the ND 1400 to measure 3-D shapes, e.g. cylinders or cones. The screen displays the feature in three dimensions. Colored highlighting of each measuring point lets you identify form errors and any filtered measured values at a glance. The ND 1400 also permits 3-D position and form tolerances, such as flatness and parallelism.

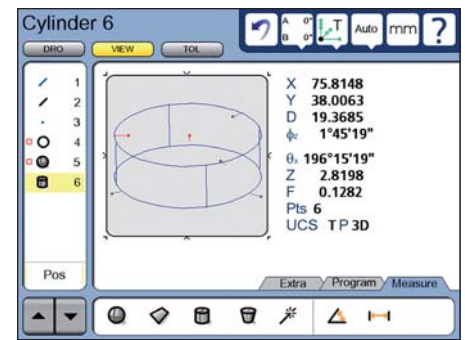

Working with the touch probe

The ND 1400 also supports you optimally while working with touch probes. You can instantaneously call commercial probing elements (normal stylus, star stylus), as well as rigid and tiltable probing heads, all of which are managed in a library, via the touchscreen. During probing the ND automatically takes the direction of probing into account, as well as the length and diameter of the stylus. Even complex parts can be rapidly measured with the five available coordinate systems.

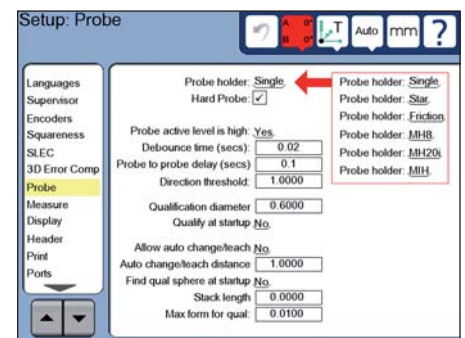

Point measurement

The ND 1400 probes the measuring points via the touch probe of the coordinate measuring machine. A triggering 3-D touch probe is connected directly to the digital readout, and the measured value is transferred automatically. With a rigid probing element the measured value must be transferred by pressing a key. You can use the comprehensive input menu to define numerous parameters.

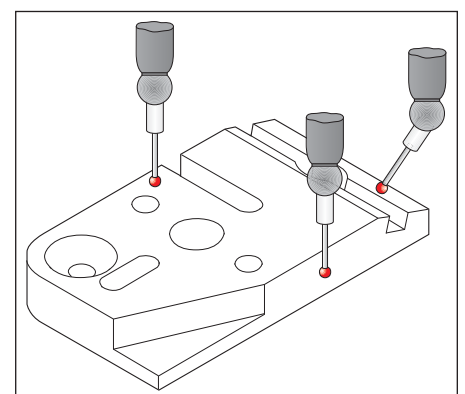



	ND 1404
Axes	4 (XYZQ)
Encoder inputs*	\sim 1 V _{PP} or \square TTL (other interfaces upon request)
Subdivision factor*	10-fold (only for 1 V _{PP})
Display step¹⁾	Adjustable, max. 7 digits Linear axes XYZ: 1 mm to 0.0001 mm Angular axis Q: 1° to 0.0001° (00° 00' 01")
Display	8.4" color flat-panel display (touchscreen); resolution: SVGA 800 x 600 pixels, for position values, dialogs and inputs, graphics functions and soft keys
Functions	<ul style="list-style-type: none"> • Measurement of two-dimensional and three-dimensional features (3-D) • Points measured via crosshairs or rigid probing element • Automatic point measurement via touch probe • Programming of features and parts • Measure Magic: automatic recognition of geometries • Graphic display of measurement results, either three-dimensional or in the three projection planes • Entry of tolerances • Five coordinate systems can be stored • Touch-probe management for the various stylus shapes
Error compensation	<ul style="list-style-type: none"> • Linear, and segmented linear over up to 1000 points • Squareness calibration • Matrix compensation over up to 30 x 30 points
Data interface	<ul style="list-style-type: none"> • RS-232-C/V.24 • USB (type A)
Touch-probe connection*	HEIDENHAIN touch probe or Renishaw touch probe
Other connections	Foot switch for two functions
Accessories	Mounting base, foot switch, 3-D demo part, protective cover
Main power input	100 V to 240 V AC (-15 % to +10 %), 43 Hz to 63 Hz
Operating temperature	0 °C to 45 °C
Protection EN 60529	IP 00, front panel IP 40
Mounting*	Tilting base or mounting base
Weight	<i>ND with tilting base</i> : approx. 4.8 kg; <i>ND with mounting base</i> : approx. 2 kg

* Please select when ordering

¹⁾ Depends on the signal period of the connected encoder as well as the subdivision factor

IK 5000 QUADRA-CHEK

– the universal PC package solution for measuring machines

IK 5000 QUADRA-CHEK, the universal PC package solution for 2-D and 3-D measuring tasks, is equally suitable as initial equipment on a machine as well as for retrofitting. It is available in versions for three or four axes, and the optional expansions make it ready for all coordinate measuring technology applications and for video measuring microscopes. You can use it to measure two- and three-dimensional geometries and their relationships.

Description

The IK 5000 QUADRA-CHEK consists of the IK 5000 slot card for the PC as well as the additional necessary slot covers and the corresponding PC software. Once installed on your PC you will have a powerful measuring station.

System requirements

The following is necessary for running QUADRA-CHEK (data for 3-D profiling option in italics):

- PC: \geq dual-core Pentium, 2.66 GHz (*quad-core Pentium, 2.8 GHz*)
- Windows XP, Vista, 7 (32 bit) operating system
- RAM: \geq 1GB (2GB)
- Hard disk: At least 500MB (1GB) available
- One PCI slot and one, two or three additional empty slots, depending on the version
- Screen:
Resolution at least 1024 x 768 pixels;
for the video function: 22" widescreen,
resolution at least 1680 x 1050 pixels
- Windows user rights: Administrator

Configuration

Various versions of the IK 5000 are available. Please see the configuration table for the model designations and various functions supported.

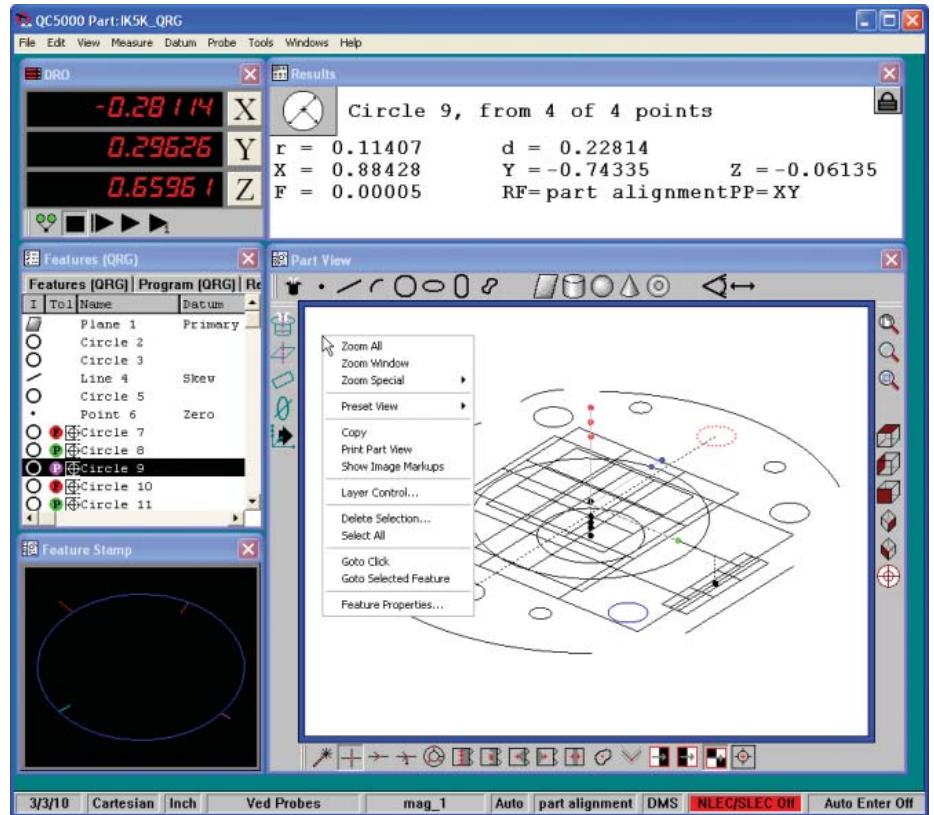

User interface

The IK 5000 QUADRA-CHEK screen shows various configurable windows and tool fields for clear and simple operation.

The **Part View** window shows the measured features with the accepted measuring points. You can also define relationships here.

The **Video** window (only in the version with video evaluation) shows the video image in real time.

The **Template** windows list all measured features, relationships and constructed features together with their values and tolerances in tables.

The feature currently being measured is shown in the **Feature Stamp** window. The **Results** window contains all corresponding information.

The current measuring position is shown in the **DRO** window.

	IK 5294	IK 5293	IK 5394-EG	IK 5394-3D	IK 5493	IK 5494-2D	IK 5494-3D	IK 5594
Axes	4 XYZQ	3 XYZ	4 XYZQ	4 XYZQ	3 XYQ	4 XYZQ	4 XYZQ	4 XYZQ
2-D geometries	●	●	●	●	●	●	●	●
3-D geometries	–	●	–	●	–	–	●	●
Optical edge finder	–	–	●	–	●	–	–	–
Video evaluation	–	–	–	●	–	●	●	●
Zoom and light control	–	–	–	●	–	●	●	●
Autofocus	–	–	–	–	–	●	●	●
Touch probe	–	●	–	●	–	–	●	TP200
3-D profiling	–	Optional	–	Optional	–	–	Optional	Optional
CNC function	–	–	–	–	●	●	●	●



	IK 5000
Axes¹⁾	3 (XYQ), 3 (XYZ) or 4 (XYZQ)
Encoder inputs*	\sim 1 V _{PP} or \square TTL (other interfaces upon request)
Subdivision factor	Up to 100-fold, selectable via dip switch; default setting: 50-fold (only for 1 V _{PP})
Display step²⁾	Adjustable, max. 7 digits <i>Linear axes XYZ:</i> 1 mm to 0.0001 mm <i>Angular axis Q:</i> 1° to 0.0001° (00° 00' 01")
Display	Via PC screen
Functions	<ul style="list-style-type: none"> • Measurement of two-dimensional features (2-D) • Measurement of three-dimensional features (3-D)¹⁾ • Point measurement with crosshairs • Programming of features and parts • Measure Magic: automatic recognition of geometries • Graphic display of measurement results • Entry of tolerances
Edge detector ¹⁾	<ul style="list-style-type: none"> • Automatic point measurement via optical edge detector
Video ¹⁾	<ul style="list-style-type: none"> • Automatic point measurement via video edge detection • Manual autofocus • Show live images • Archiving and output of live images • Zoom and light control, programmable (with the <i>Light/Zoom</i> versions) • Video connection for digital USB camera (with the <i>Video</i> versions) • Light control over six light sources and zoom control (with the <i>Video</i> and <i>Light/Zoom</i> versions)
CNC ¹⁾	<ul style="list-style-type: none"> • Automation of measurement tasks • Axis control (for XYZQ) for servo and stepper motors • Autofocus via stepper-motor control (Z axis) • CNC outputs and inputs for joystick
3-D profiling¹⁾ (option)	<ul style="list-style-type: none"> • Importing of CAD models • Probing of tested object and comparison with the CAD model • Flexible output of measurement results
Error compensation	<ul style="list-style-type: none"> • Linear, and segmented linear over any number of points • Squareness calibration • Matrix compensation over any number of points
Other connections	<ul style="list-style-type: none"> • Foot switch for two functions
Accessories	Foot switch, fiber-optic cables, holder for fiber-optic cables, servo amplifier, calibration standard, demo part, distribution cable
PC interface	PCI
Dimensions	100 mm x 250 mm

* Please select when ordering

¹⁾ See the configuration table for possible combinations

²⁾ Depends on the signal period of the connected encoder as well as the subdivision factor

IK 5000 QUADRA-CHEK

– Functions

The innovative operator guidance provides self-explanatory information about the various functions. It already supports you while setting up the coordinate system (aligning the part and specifying the datum).

Various predefined features are available for measurement, depending on the version:
2-D measurement: Point, line, circle, slot, rectangle

3-D measurement: Plane, cylinder, cone, sphere

The "Measure Magic" function makes measurement especially easy: it selects that feature which best matches the shape implied by the points probed.

With IK 5000 QUADRA-CHEK you can define features yourself (for example, a circle whose position and dimensions are exactly specified). In addition, you can establish relationships (distances, angles) between features.

Measuring programs that you create yourself or record automatically simplify the efforts necessary for repeated parts. The digital readout graphically takes you to the next measuring position during program run.

Depending on the version, IK 5000 QUADRA-CHEK probes the measuring points of plane (2-D) contours either automatically or manually via crosshairs, via optical edge detection, or via a video camera.

For 3-D contours, such as planes, cylinders, cones and spheres, the measuring points are probed with a touch probe. If a triggering touch probe is used the values are transferred automatically. With rigid probing elements a key must be pressed.

The measured features can be clearly displayed either in three dimensions or in one of the three projection planes.

Multi-sensor scanning

Along with the usual method for measuring points, the IK 5494 and IK 5594 versions permit multi-sensor scanning: in addition to the video camera, the measuring machine is also equipped with a touch probe. You can then use the touch probe to measure 3-D features on the object, and enjoy the advantages of video evaluation for 2-D features. The integrated probe library manages the various measurement tools for you, whether they be optical, video, laser or touch-probe systems.

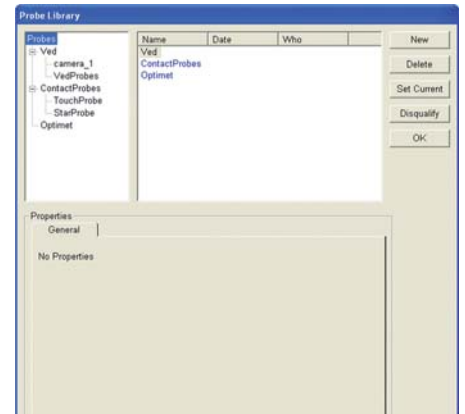

Constructed features

QUADRA-CHEK gives you several possibilities for determining dimensions:

- Measuring the features
- Calculating the features (e.g. the enter point of a measured circle)
- Establishing a relationship between features (e.g. distance between two circle center points, angle between two lines)

However, you can also construct new features from existing features and from relationships. The properties of these constructed features can then be seen directly in the parts view.

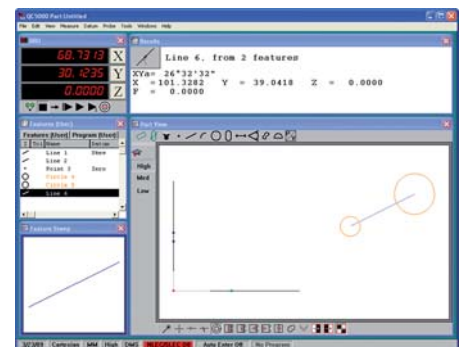

Data management

The integrated data-report generator for customized forms, databases and tolerance checks is used to archive, export and import data in numerous formats. Use the integrated spreadsheets for complex and non-standard calculations. Simply send your customized reports to a printer, or make the data available to other users in a database.

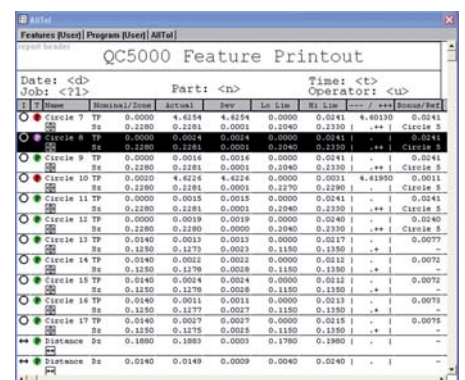

Functional Part View window

QUADRA-CHEK provides you with a comprehensive, graphical Part View window. You can choose between a 3-D view, or a projection in the XY, YZ or ZX planes. Additionally, you can magnify, reduce, zoom, shift or rotate the views. You can define tolerances and constructed features in any view. The "pass/fail" color coding makes it easy to determine whether the part matches the specifications.

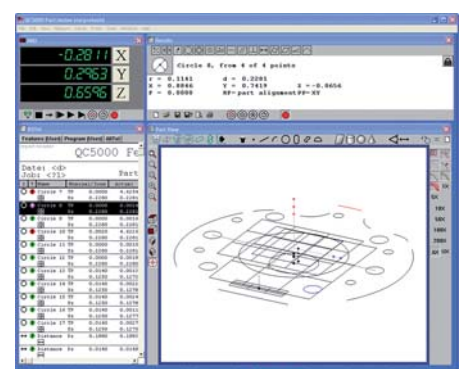

Programming of parts

Difficult and repetitive measuring tasks can be simplified with the aid of a program that you either create yourself or record automatically during measurement of the first part. QUADRA-CHEK learns the reference points, the sequence of measurements, tolerances and data-output commands. QUADRA-CHEK visually leads you to the features to be probed when the program is run. The program view also provides you with an optimum overview of the process.

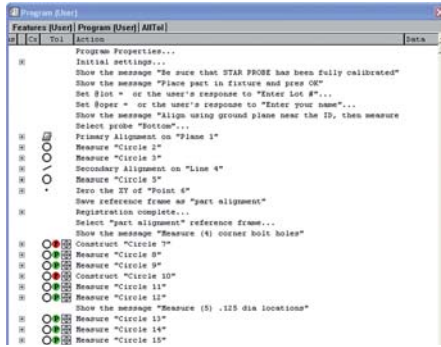

Excerpt from the possibilities for the construction of features:

2-D possibilities

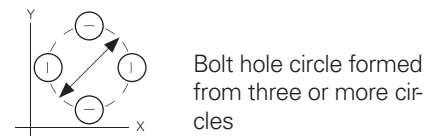
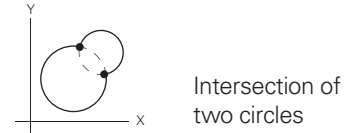
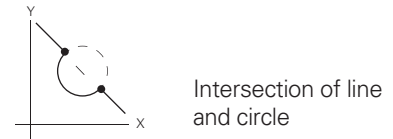

Integrated image processing

The integrated image processing function included with the video-function versions provides a special benefit: the video image is shown on the screen in real time and can be saved. QUADRA-CHEK can even assume complete control of the illumination and the motor zoom. A digital USB camera can be connected.

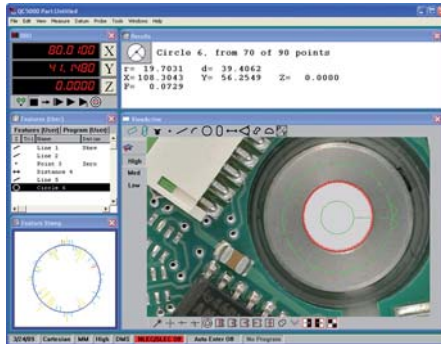

In order to quickly and directly compare the actual status and nominal status, import the parts drawing in DXF or IGES format, and place it over the video image.

Axis positioning

The CNC versions of IK 5000 QUADRA-CHEK work as full-fledged controls, directly controlling the positioning of the X, Y, Z and Q axes. Servo motors or stepper motors can be connected. The necessary servo amplifiers for two or three axes are available as accessories.

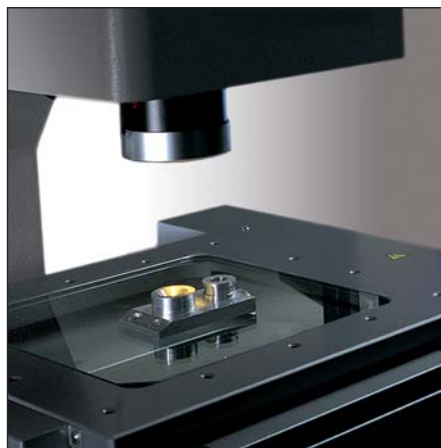

Automating

Programs running in combination with the CNC function of IK 5000 QUADRA-CHEK run automatically. This minimizes the effects of subjective assessments, and increases data throughput noticeably. By automating series of measurements and complex procedures, you spare yourself the strain of performing repetitive measuring tasks.

3-D profiling

The 3-D profiling option simplifies the measurement and evaluation of 3-D contours on multi-sensor and tactile measuring machines: First you import the CAD model, then you measure the real part, and finally you use the 3-D profiling function to compare the measured points with the CAD model. The measurement results are displayed graphically and can be managed in the usual manner. They can also be transferred to other quality systems.

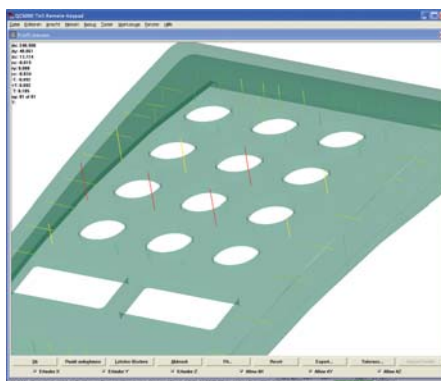

3-D possibilities

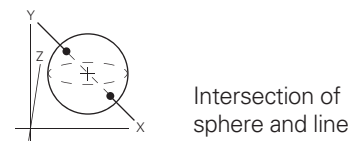
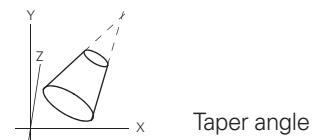
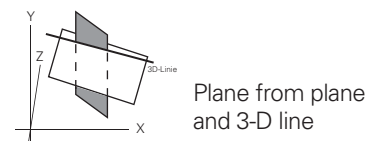
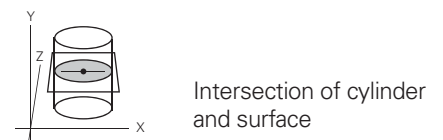

ND 1200T TOOL-CHEK

– the digital readout for tool presetters

The TOOL-CHEK ND 1200T digital readout is designed specifically for tool presetters. It supports the X and Z axes.

Description

The ND 1200T has a monochrome flat-panel display. The robust, die-cast aluminum enclosure meets the demands of production floors.

Functions

The self-explanatory user guidance of the TOOL-CHEK ND 1200T digital readout provides you with optimum support for all functions.

You can define up to 99 tool adapters for the tool holder. You can select either an absolute reference point, or one that refers to a master adapter. You can define the axis assignment and counting direction separately for each adapter.

Tool measurement usually consists of measuring the length and diameter or radius of a tool. You can also measure radii (e.g. for ball-nose cutters) and angles (e.g. for indexable inserts or lathe tools). The ND 1200T stores up to 300 tools. You can respectively show and print each actual value, nominal value and deviation.

You can group various tools, e.g. those that are necessary for machining a certain part. Create this setup plan either by selecting the tools from the tool list, or by measuring each tool.

For tools that are too large to be shown on the projector, such as teeth with a radius, you can freeze an axis for measurement. If a tool has more than one tooth, then you use the incremental function to ascertain the tool data in reference to the master tooth as well.

Data interfaces

You use the data interfaces to transmit the tool data and to import and export settings, compensation values and saved tools. The RS-232-C/V.24 serial interface enables communication with a PC. You can connect printers or memory media to the USB port.

Measuring radii and angles

You probe several points with the crosshairs in order to measure the radius. The digital readout calculates the radius and any form error from this. In order to measure a cutting edge angle, probe the two sides of the angle at two points each. The results are the intersection of the two lines as well as the inside angle "A".

T	L_00	mm
⊖	X	4.769
⊖	Z	0.111
	r	0.145
	F	0.000
Actual	Center	C Max

Label printing

You can connect various label printers via the USB port. The control commands necessary for this are already set, and can be called via the menu function.

Print	mm	
About	Auto Label	Yes
Display	Auto Report	No
Encoders	Label Format	Metronics1
Hot Keys	Pre Line	
Print	Post Line	10 13
Form Chars	Pre Form	
Ports	Label Lines	5
Supervisor	Skip Lines	0
Squareness	Label Indent	0
LEC		
List		

Tool list

You can also store the data of all measured and numbered tools, and even print this data in a clearly structured list. Use the menu to determine which information is included in the list.

Tool list: Temp	TOOL-#	SG	POT	Z-ACT.	X-ACT.	Z-NOM.	X-NOM.	Z-DEV.	X-DEV.	R/D	I/MM
	10	01	4	100.1000	28.1000	0.0000	0.0000	100.1000	28.1000	D	mm
	20	01	5	100.1400	29.9400	0.0000	0.0000	100.1400	29.9400	D	mm
	30	01	6	99.9400	29.4600	0.0000	0.0000	99.9400	29.4600	D	mm
	40	01	7	100.1200	29.8000	0.0000	0.0000	100.1200	29.8000	D	mm
	50	01	8	100.1500	29.5600	0.0000	0.0000	100.1500	29.5600	D	mm
	60	01	10	99.8800	30.2000	0.0000	0.0000	99.8800	30.2000	D	mm

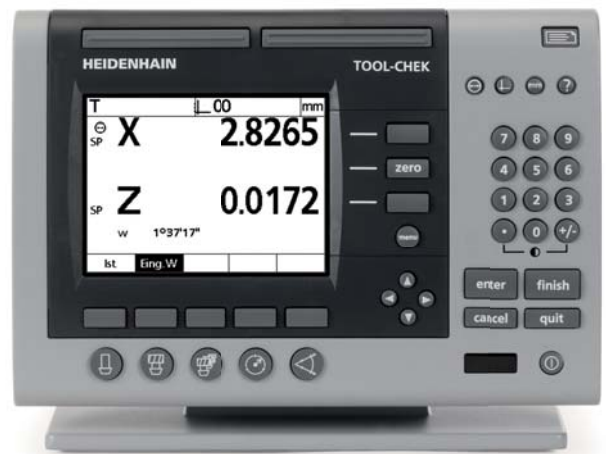

ND 1202T	
Axes	2 (XZ)
Encoder inputs*	\sim 1 V _{PP} or \square TTL (other interfaces upon request)
Subdivision factor*	10-fold (only for 1 V _{PP})
Display step¹⁾	Adjustable, max. 7 digits <i>Linear axis:</i> 1 mm to 0.0001 mm <i>Angular axis:</i> 1° to 0.0001° (00° 00' 01")
Display	5.7" monochrome flat-panel display for position values, dialogs and inputs, and soft keys
Functions	<ul style="list-style-type: none"> • Point measurement with crosshairs • 99 tool adapters • Memory for 300 tools • Counting direction and axis assignment depend on the adapter • Radius/diameter switching • Entry of tolerances • Circle and angle measurement
Error compensation	<ul style="list-style-type: none"> • Linear, and segmented linear over up to 30 points • Parallelism error
Data interface	<ul style="list-style-type: none"> • RS-232-C/V.24 • USB (type A)
Other connections	Foot switch for two functions, or remote keypad
Accessories	Foot switch, remote keypad, protective cover
Main power input	100 V to 240 V AC (–15 % to +10 %), 43 Hz to 63 Hz
Operating temperature	0 °C to 45 °C
Protection EN 60529	IP 00, front panel IP 40
Mounting*	Tilting base or mounting base
Weight	<i>ND with tilting base:</i> approx. 4.8 kg; <i>ND with mounting base:</i> approx. 2 kg

* Please select when ordering

¹⁾ Depends on the signal period of the connected encoder as well as the subdivision factor

ND 2100G GAGE-CHEK

– the digital readouts for multipoint inspection apparatuses

The ND 2100G GAGE-CHEK readouts are versatile metrology displays for measuring and inspection tasks in manufacturing and quality assurance. With inputs for up to eight encoders, they are predestined for multipoint measurements from simple pass/fail detection up to complex SPC evaluation.

Description

The ND 2100G readouts have a robust, die-cast aluminum enclosure, and a keyboard suited to their environment. A large, graphic, color screen displays the measured values, the soft-key row and other information.

Functions

The inputs can be assigned and combined as desired with mathematical, trigonometric or statistical formulas. This makes it possible to measure even complex dimensions such as thickness, flatness, volume and more. The results are displayed numerically or graphically as a color bar graph or a dial, or archived for statistical process control (SPC). The GAGE-CHEK can be configured for basic or advanced applications. Soft keys and hot keys can be adapted as required. The minimum/maximum function of the ND 2100G readouts monitors and stores the highest and lowest measured or calculated value. Warning and tolerance limits can be assigned to each display value. Results outside of the tolerance are marked with a different color. An acoustic alarm sounds simultaneously. Tolerance values, SPC parameters and custom formulas are stored for individual parts. GAGE-CHEK can manage up to 100 parts, each with up to 16 visible measurement features and 16 hidden measurement features. The rapid acquisition of measurement data makes monitoring dynamic events, such as the eccentricity of a rotating shaft, possible.

Data interfaces

The GAGE-CHEK features various interfaces for communicating with parent systems:

- RS-232-C/V.24 for PC, also for remote operation of the GAGE-CHEK
- USB

Position display

The display values appear in large, easy-to-read numbers. Values outside the tolerance are color-coded, immediately notifying you of errors.

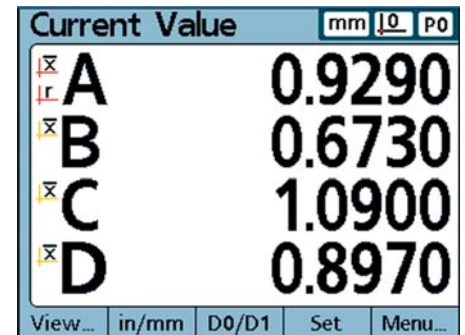

Bar diagram

You can select to have the values shown as a color-enhanced vertical or horizontal bar graph. The defined warning limits and tolerance limits provide instant feedback. If these limits are exceeded, the color of a bar changes from green to yellow or red, informing you explicitly of critical dimensions.

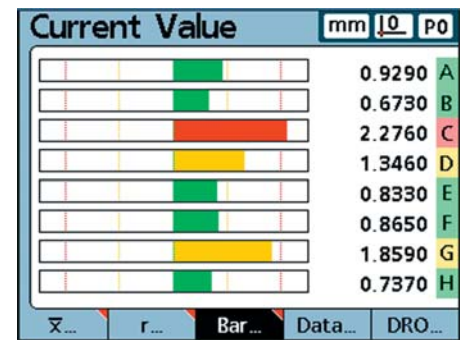

SPC and data storage

GAGE-CHEK includes integrated SPC studies such as mean value charts (X bar) and range charts (R). Min, max, sigma, cp and cpk are also calculated, and are clearly displayed as a graph or histogram. Historical raw data can be saved in a tabular numeric display. Each dimension and all data are time and date stamped.

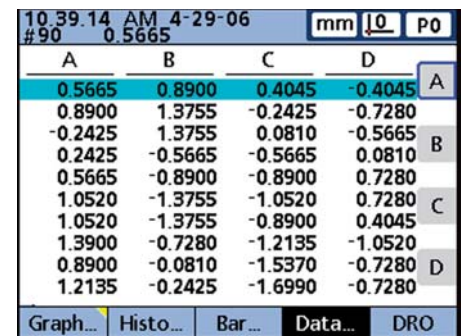

Formulas and combinations

You can use mathematical and trigonometric formulas, as well as logical conditions, to combine individual measured values or measurement sequences with each other, and so create complex calculations. This can be used, for example, to calculate and display the circumference of a turned part, the volume of a cube, or the angle between two cams, and also to assign tolerance limits to these values.

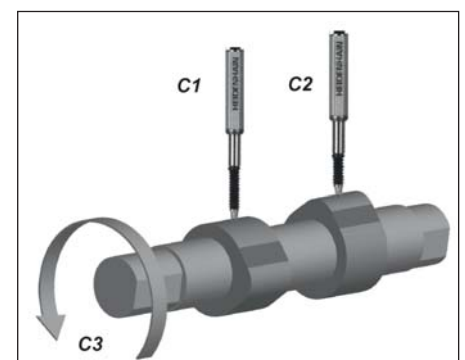



	ND 2104 G	ND 2108 G
Axes	4	8
Encoder inputs*	~ 1 V _{PP} □LITTL or EnDat 2.2 (other interfaces upon request)	
Subdivision factor	10-fold (only for 1 V _{PP})	
Display step¹⁾	Adjustable, max. 7 digits Linear axis: 1 mm to 0.00001 mm Angular axis: 1° to 0.0001° or 00° 00' 01"	
Display	5.7" color flat-panel display for position values, dialogs and inputs, graphics functions and soft keys	
Functions	<ul style="list-style-type: none"> • Part programming of up to 100 parts • Graphic display of measurement results • Sorting and tolerance checking using tolerance and warning limits, with display as a bar graph • Measurement series with min./max. value storage • Mathematical and trigonometric formulas • Functions for statistical process control (SPC) • Graphic display of measurement results and distribution • Data storage of values and formulas • Convenient diagnostics of the connected encoders (only EnDat 2.2) 	
Error compensation	<ul style="list-style-type: none"> • Linear, and segmented linear over up to 60 points 	
Data interface	<ul style="list-style-type: none"> • RS-232-C/V.24 • USB (type A) 	
Switching inputs	5 TTL inputs (freely definable)	
Switching outputs	12 TTL outputs (freely definable) 2 relay outputs	
Other connections	Foot switch for two functions	
Accessories	Mounting base, foot switch, remote keypad, protective cover	
Main power input	100 V to 240 V AC (-15 % to +10 %), 43 Hz to 63 Hz; 30 W	
Operating temperature	0 °C to 45 °C	
Protection EN 60529	IP 40	
Mounting*	Tilting base or mounting base	
Weight	ND with tilting base: approx. 4.8 kg; ND with mounting base: approx. 2 kg	

* Please select when ordering

¹⁾ Depends on the signal period of the connected encoder as well as the subdivision factor

ND 200

– the digital readouts for for measuring and testing stations

The ND 200 series offers digital readouts for one axis. Due to their performance range they are predestined for measuring and inspection stations, but are also intended for simple positioning tasks. The universal encoder input permits connection of all incremental encoders with 11 μ APP and 1 VPP and absolute encoders with the EnDat 2.2 interface from HEIDENHAIN.

Description

The ND 200 series features a sturdy aluminum die-cast housing. A graphic TFT monitor displays the measured values, the status and the soft-key row. The splash-proof full-travel keyboard is built for the workshop.

Functions

The standard **ND 280** readout provides the basic functions for simple measuring tasks. The **ND 287** features numerous functions for measuring and processing individual positions, for example sorting and tolerance check mode, minimum/maximum value storage, measurement series storage. These data make it possible to calculate mean values and standard deviations and display them in histograms or control charts. With its modular design, the ND 287 permits connection of a second encoder for sum/difference measurement or of an analog sensor, for example for temperature compensation.

Data interfaces

The ND 28x have serial interfaces for measured value transfer to a PC or printer, for input/output of parameters and compensation value lists, and for diagnostics:

- USB
- RS-232-C/V.24
- Ethernet 100BaseT (option, only with ND 287)

The measured value transfer can be started at the ND keyboard, through an external command, through the RS-232-C/V.24 software command CTRL B, or by an adjustable internal clock.

Accessories:

Encoder module

Input assembly for second encoder with 1 VPP, 11 μ APP or EnDat 2.2. interface
ID 654017-01

Analog module

Input assembly for ± 10 V analog sensor
ID 654018-01

Ethernet module

ID 654019-01

Sorting and tolerance checking

With the sorting function of the ND 287, workpieces can be inspected for dimensional accuracy and divided into classes. The result is indicated in the status display in color or with symbols; in addition, a corresponding signal is available at the switching outputs.

Display freeze

To be able to read the display reliably in spite of quickly changing values you can send an external signal to hold the display. The true position value is counted internally.

Combination with a second encoder

A second encoder or a sensor on the ND 287 can be connected through an optional **encoder module** or **analog module** input assembly. The data from two encoders can be combined through mathematical operands. The result and the two measured values are saved. This permits further areas of application, such as the sum/difference display of two encoders or temperature compensation through a temperature sensor.

Recording and evaluating series of measurements

The ND 287 provides a measured-value memory for recording series of measurements. The measurement value, minimum, maximum or difference can be displayed during the serial measurements. In addition, the displayed value can be checked with the classification function for compliance to tolerances. The saved measured values are evaluated and represented as:

- Statistical view (mean value, x standard deviation s , range r)
- Diagram (graphical display of the measured values with minimum/maximum and mean values as well as tolerance limits)
- Measured value overview as a table

Statistical process control (SPC)

For SPC, the ND 287 saves up to 1000 measured values in a nonvolatile FIFO memory. They are evaluated with the following functions:

- Statistical view of measured values in the FIFO memory
- Measured value overview as a table
- Diagram of the last 30 measured values
- Histogram in ten classes with probability density function and process capability indexes c_p and c_{pk} .
- Control charts for mean value, x standard deviation s , and range r

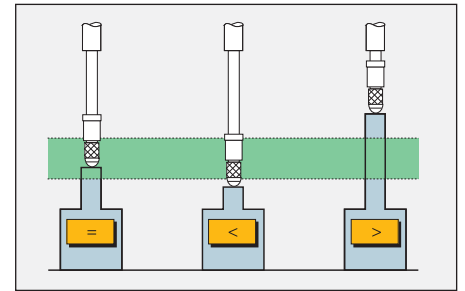

Sorting and tolerance checking

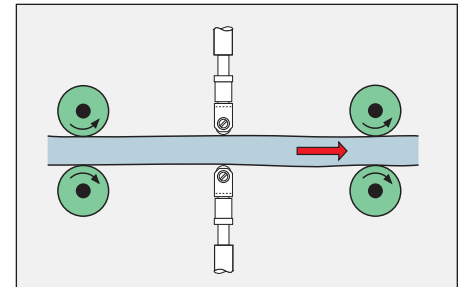

Sum measurement

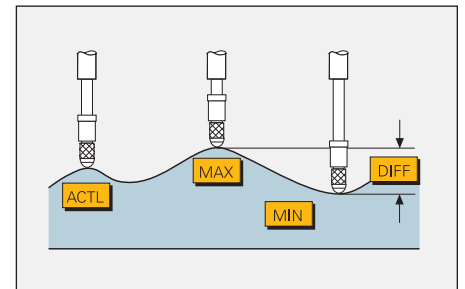

Measured value acquisition

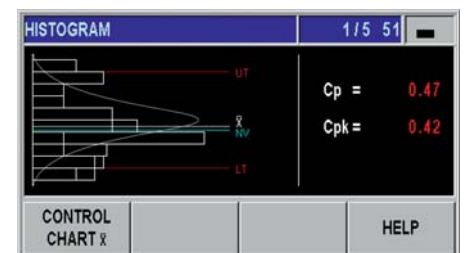



	ND 280	ND 287
Axes	1	1; option: second input through encoder module
Encoder inputs¹⁾	$\sim 1 V_{PP}$, $\sim 11 \mu A_{PP}$ or EnDat ²⁾	$\sim 11 \mu A_{PP}$, $\sim 1 V_{PP}$ or EnDat ²⁾
Subdivision factor	4 096-fold	
Display step³⁾	Adjustable, max. 9 decades <i>Linear axis:</i> 0.5 to 0.002 μm <i>Angular axis:</i> 0.5° to 0.00001° or 00°00'00.1"	
Analog input	–	Option: $\pm 10 V$ through analog module; resolution 5 mV
Display	Monochrome flat-panel display	Color flat-panel display
	Position values, dialogs and input, graphic functions and soft keys	
Functions	<ul style="list-style-type: none"> • REF reference-mark evaluation for distance-coded or single reference marks • 2 datums • Distance-to-go mode • Integrated help and diagnostics • Remote operation via serial interface 	
	–	<ul style="list-style-type: none"> • Sorting and tolerance checking • Measurement series with min./max. value storage • Saving measured values (max. 10 000) • Functions for statistical process control (SPC) • Graphic depiction of distribution/histogram • Sum/difference display (with 2nd encoder module) • Thermal compensation (with analog module)
Axis-error compensation	<i>Linear axis:</i> Linear and multipoint over up to 200 points <i>Angle axis:</i> Multipoint linear with 180 compensation points (every 2°)	
Data interface	RS-232-C/V.24; USB (type B)	
	–	Option: Ethernet 100BaseT, via Ethernet module
Switching outputs For tasks in automation	–	<ul style="list-style-type: none"> • Zero crossover; trigger points 1 and 2 • Sorting signals "<" and ">" • Errors
Switching inputs For tasks in automation	–	<ul style="list-style-type: none"> • Zero reset, preset • Cross over reference point and ignore reference signals • Measured value output or display freeze • Start measurement series • Minimum/maximum/difference display • Gating of the two encoder inputs • Sum or difference display • Display measured value 1 or measured value 2
Main power input	100 to 240 V AC (–10 % to +15 %), 48 Hz to 62 Hz; 30 W	
Operating temperature	0 °C to 45 °C	
Protection EN 60 529	IP 40, front panel IP 54	
Weight	Approx. 2.5 kg	

¹⁾ Automatic detection of interface

²⁾ Purely serial, no evaluation of the incremental signals

³⁾ Depends on the signal period of the connected encoder (display step \approx signal period/4 096)

Mounting

Dimensions of ND 100/ND 200



ND 123



ND 287

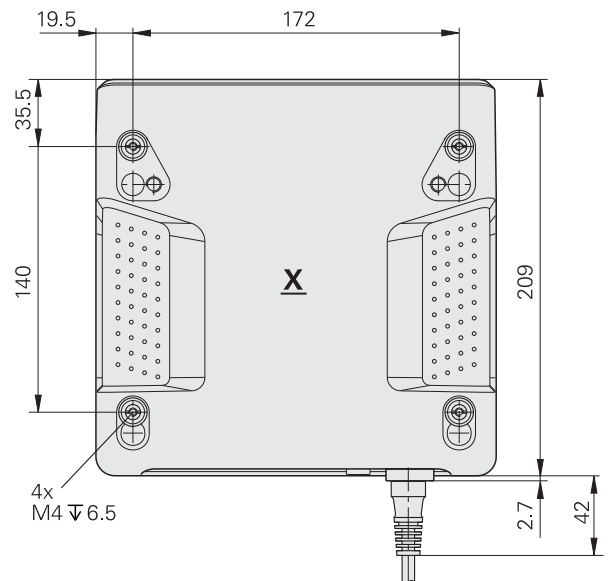
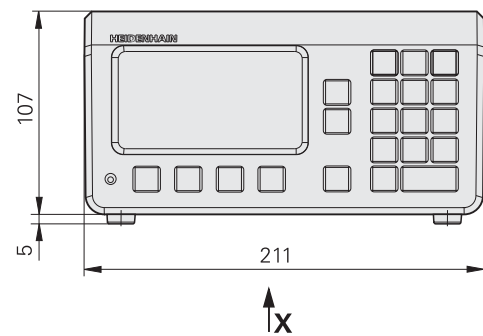
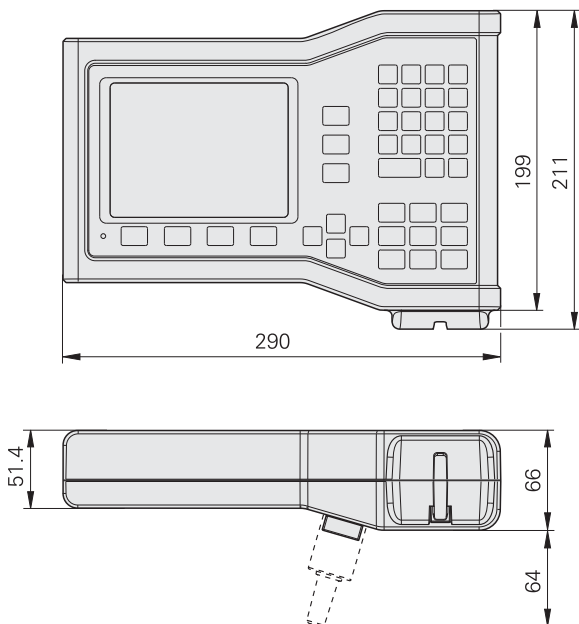

mm

 Tolerancing ISO 8015
 ISO 2768 - m H
 < 6 mm: ±0.2 mm

Dimensions of ND 1000/ND 2000



ND 1300 with tilting base

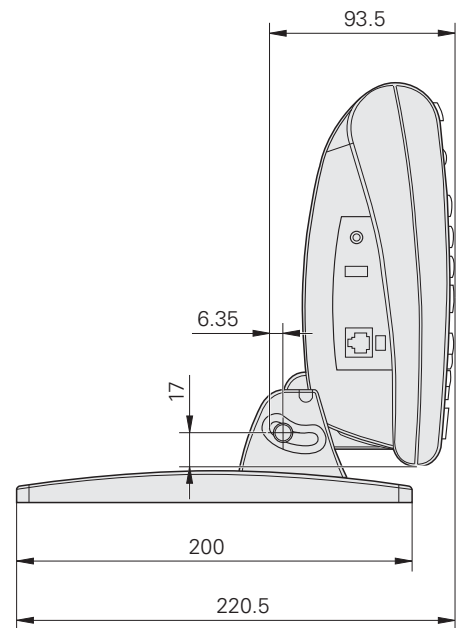
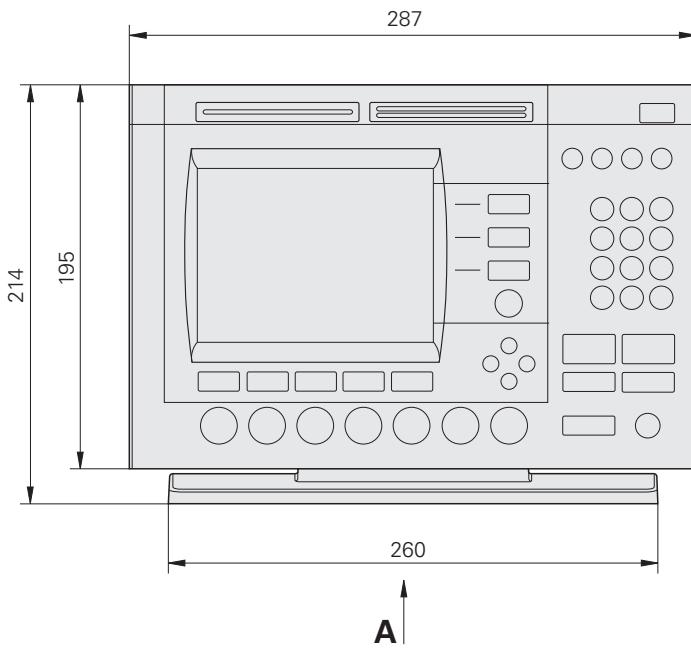

mm

 Tolerancing ISO 8015
 ISO 2768 - m H
 < 6 mm: ±0.2 mm

Mounting

Mounting the ND 100/ND 200

ND100 series

You can set up the ND 12x either on a mounting arm on the machine, with the aid of a mounting adapter, or install it in a control panel. The parts required for fastening the display are included in delivery. They enable you to rotate and tilt the display. The mounting arm, tilting base, and mounting frame are available as accessories:

Tilting base

ID 625491-01

Mounting frame

ID 647702-01

For mounting the ND 12x in a housing or operating panel.

Accessories:

Mounting arm, straight

ID 382893-01

You can use the mounting arm to easily place the display at a conveniently operable position. It can be attached to the machine and swiveled by either a bracket or a hex bolt. The display is attached to the mounting arm via its own tilt/swivel mount.

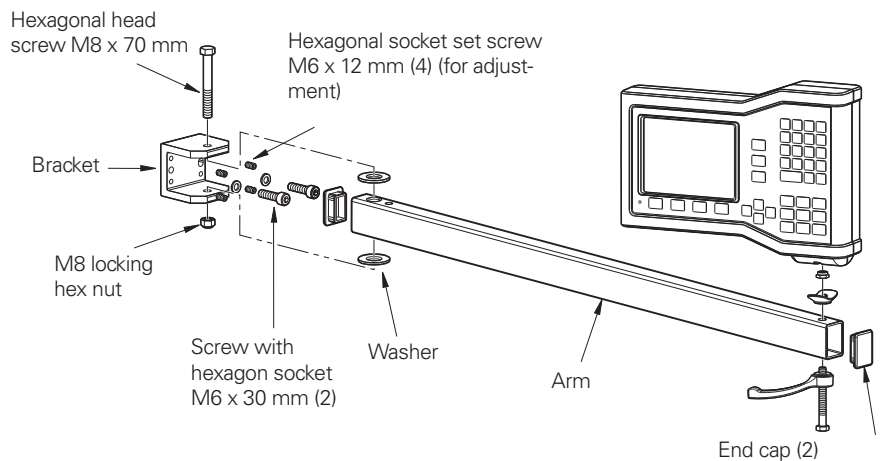
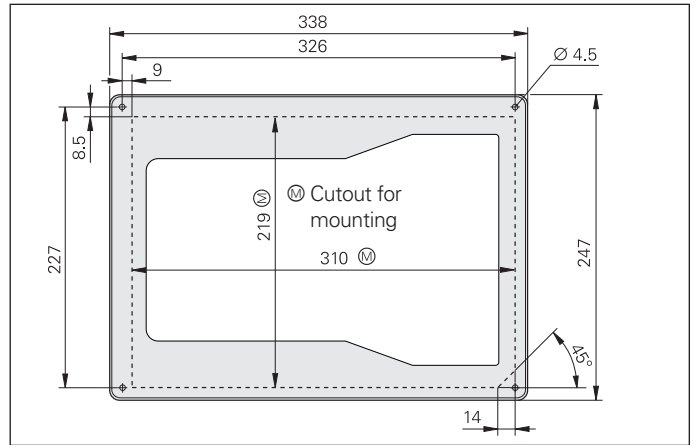
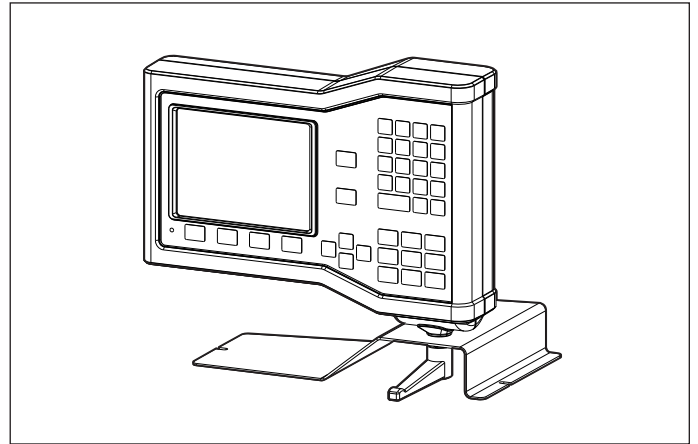

ND 200 series

The ND 200 digital readouts were conceived as bench-top units. They can easily be stacked. Recesses on the top prevent the stacked units from moving out of place.

You can secure the ND 28x from below by using M4 screws on a base plate.

Two ND 28x readouts fit next to each other in a 19" housing. A mounting base is available as an accessory for mounting in a 19" housing.

Accessories:

Mounting adapter for 19" housing

ID 654020-01

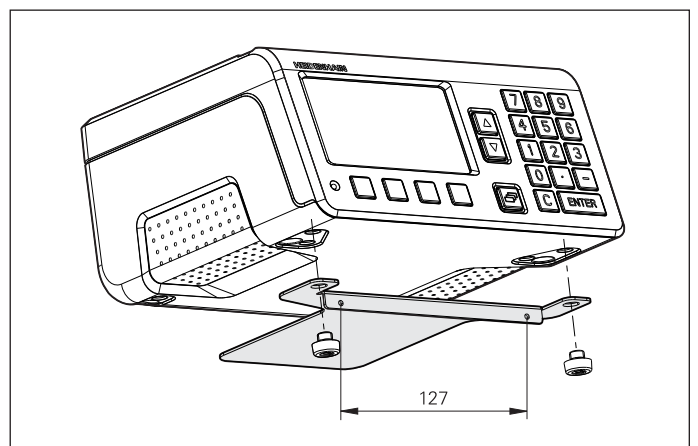

Mounting and protection of ND 1000/ND 2000

Mounting

The ND 1000 and ND 2000 are shipped with either a tilting base or a mounting base.

Tilting base

The readout can be used as a tabletop unit when placed on the tilting base. The readout can then be tilted forward or backward by up to 20° for the best reading angle. The tilting base can be attached with M5 screws.

ID 382892-02

Mounting adapter

The mounting base is used to attach the ND 1000 or ND 2000 to a mounting arm or directly to the machine. It also permits tilting of the readout.

ID 682419-01

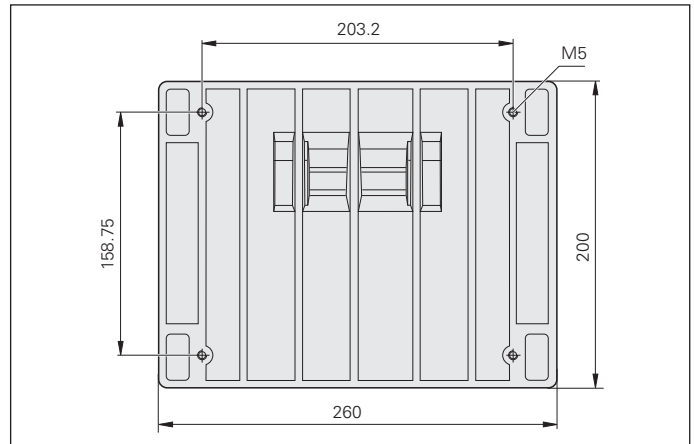

Mounting adapter

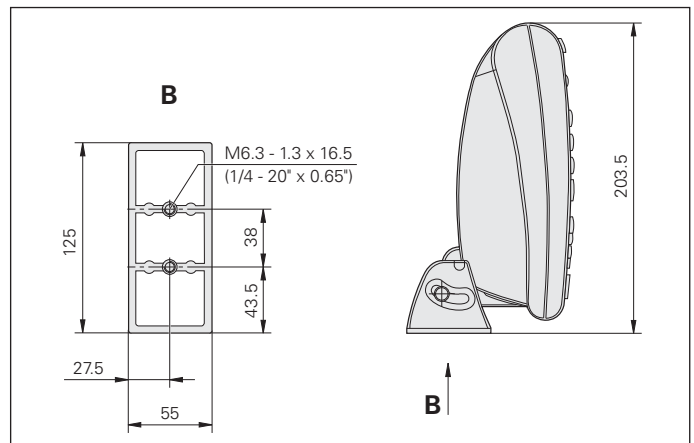

Protective cover (accessory)

Protective covers are accessories for protecting the keyboard and screen of the ND 1000/ND 2000 from becoming soiled. The display can still be easily read through the transparent protective covers. They fit themselves optimally to the front of the unit, without impairing the ease of operation.

ND 11xx (1/2 axes) ID 681051-02

ND 11xx (3/4 axes) ID 681051-03

ND 21xx

ND 12xx

ID 681051-01



Accessories

Calibration and demonstration parts

HEIDENHAIN offers various calibration parts as accessories in order to calibrate the optical and tactile edge detection methods.

Calibration standard

For the calibration of video measuring machines, measuring microscopes and profile projectors. It can be traced back to national or international standards.

ID 681047-01



2-D demo part

The 2-D demo part is included with the ND 1200, ND 1300 and IK 5000. The application examples in the User's Manuals are based on this part. It can be reordered if a replacement is necessary.

ID 681047-02

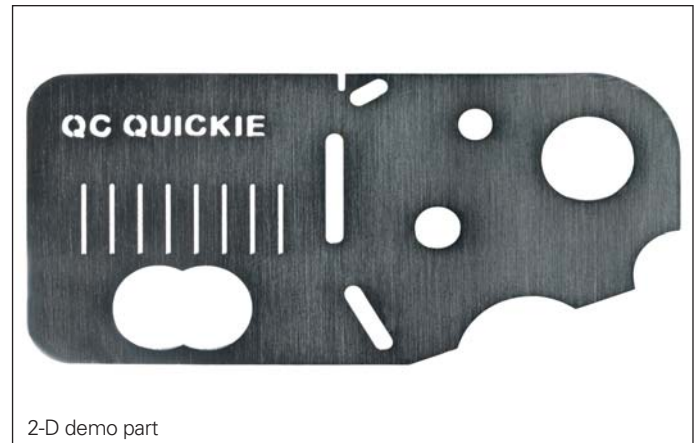

3-D demo part (accessory)

Demo part for touch-probe applications. Examples in the ND 1400 and IK 5000 User's Manuals are based on this part.

ID 681048-01



3-D demo part for multi-sensor scanning (accessory)

Demo part specifically for applications that combine touch-probe systems and video edge detection. It is used for the examples in the IK 5000 User's Manual.

ID 681048-02

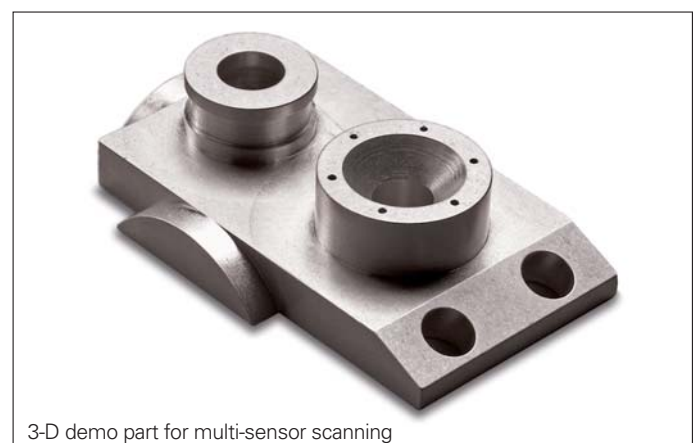

External control elements

The digital readouts and the PC package can be operated easily and intuitively. However, remote operability may also be useful and convenient in some situations. The following components are available for remote operation:

Foot switch (accessory)
With two freely assignable keys
Cable length: 2.4 m

For ND with RJ 45 connector
ID 681041-01

For IK 5000 with 3-pin DIN connector
ID 681041-02



Foot switch

Remote keypad (accessory)
For remote operation of the digital read-outs; features a numeric keypad and "enter" and "finish" keys; cable length: 4.5 m; with RJ 45 connector.

ID 681043-01



Remote keypad

Joystick (accessory)
For remote operation and sensitive traversing of axes for ND 1300 and IK 5000. With 15-pin D-sub connector.

Without trackball	ID 681044-02
With trackball	ID 681044-01
With trackball and Z-focus fine adjustment	ID 681044-05



Joystick without trackball



Joystick with trackball and Z-focus fine adjustment

Accessories

Optical edge detector

Two fiber-optic cables are necessary for edge detection with the optical edge detector. One fiber-optic cable is attached to the projection screen with a transparent holder. The second cable is attached near the transmitted light source so that the fibers point toward the light source. The following accessory components are required.

Fiber-optic cable (accessory)

With one right-angle end and an SMA connector (subminiature A) for ND or IK.

Bend radius: ≥ 25 mm

Temperature: ≤ 100 °C

Lengths 2 m, 3 m, 5 m

ID 681049-xx

Holder (accessory)

With a hole for accepting the right-angle end of fiber-optic cables. Transparent design so that it can be attached to the projection screen.

Lengths: 350 mm, 600 mm, 760 mm

ID 681050-xx

Fiber-optic cable connector (accessory)

Two SMA connectors (subminiature A) for connecting an integrated edge detector.

Bend radius: ≥ 25 mm

Temperature: ≤ 100 °C

Lengths 2 m, 3 m, 5 m

ID 681049-xx



Servo amplifiers

Servo amplifiers for CNC

For the versions with CNC axis positioning, HEIDENHAIN supplies the appropriate servo amplifiers both for stepper motors and for servo motors. The connecting cables are available upon request.

Servo amplifier for CNC stepper motor (accessory)

For two-phase stepper motors
Rated voltage: 48 V DC

For 2 axes:

Current per axis: ≤ 2.5 A
Power per axis: ≤ 120 W

Line voltage: 240 V AC: ID 681045-01
Line voltage: 120 V AC: ID 681045-03

For 3 axes:

Current per axis: ≤ 1.67 A
Power per axis: ≤ 80 W

Line voltage: 240 V AC: ID 681045-02
Line voltage: 120 V AC: ID 681045-04

Servo amplifier for CNC servo motor (accessory)

For servo motors with brushes
Line voltage: 240 V AC
Rated voltage: 48 V DC

For 2 axes:

Continuous current per axis: ≤ 3 A
Rated power per axis: ≤ 150 W

Line voltage: 240 V AC: ID 681046-01
Line voltage: 120 V AC: ID 681046-05

For 3 axes:

Continuous current per axis: ≤ 2 A
Rated power per axis: ≤ 100 W

Line voltage: 240 V AC: ID 681046-02
Line voltage: 120 V AC: ID 681046-06

Servo amplifier for zooming

A separate servo amplifier is necessary for the zoom function of the ND 1300. It can also be used for the IK 5000 if the performance of the integrated amplifier does not suffice (0.4 W).

Servo amplifier for zooming with stepper motor

(accessory)

For two-phase stepper motors in open-loop systems (e.g. for Navitar zoom)

Line voltage: 100 V to 240 V AC
Rated voltage: 12 V DC
Current: ≤ 2 A
Power: ≤ 160 W

With EU power cable: ID 722334-02
With U.S. power cable: ID 722334-01



Servo amplifier for CNC stepper motor



Servo amplifier for CNC servo motor



Servo amplifier for zooming with stepper motor

Interfaces

Digital readouts

The digital readouts feature interfaces for encoders, for communication and for external components.



	ND 122 ND 123	ND 1102 ND 1103 ND 1104	ND 1202 ND 1203 ND 1204	ND 1302 ND 1303 ND 1304		ND 1404	ND 1202 T	ND 2104 G ND 2108 G	ND 280 ND 287
Encoders									
1 V _{PP} /11 μA _{PP}	-/-	●/-	●/-	●/-	●/-	●/-	●/-	●/-	●/
TTL	●	●	●	●	●	●	●	●	-
EnDat 2.2. ¹⁾	-	-	-	-	-	-	-	●	● ²⁾
Touch probe	-	● ³⁾	-		-	● ³⁾	-	-	-
Video	-	-	-	● ⁴⁾	-	-	-	-	-
Fiber-optic cable	-	-	Option ⁵⁾	-	●	-	-	-	-
Sensor ± 10 V	-	-	-	-	-	-	-	-	Option ²⁾
Data									
USB	Type B	Type A	Type A	Type A	Type A	Type A	Type A	Type A	Type B
RS-232-C/V.24	-	●	●	●	●	●	●	●	●
Ethernet	-	-	-	-	-	-	-	-	Option ²⁾
Light control	-	-	-	-	Option	-	-	-	-
Zoom	-	-	-	-	Option	-	-	-	-
CNC outputs	-	-	-	-	Option	-	-	-	-
Foot switch	-	●	●	●	●	●	●	●	-
Remote keypad	-	-	●	●	●	-	●	-	-
Switching outputs	-	-	-	-	-	-	-	12 TTL	6 TTL
Switching inputs	-	-	-	-	-	-	-	5 TTL	12 TTL

- = Available
- = Not available
- 1) Purely serial, no evaluation of the incremental signals
- 2) Only with ND 287
- 3) HEIDENHAIN touch probe or Renishaw touch probe
- 4) S-Video and composite
- 5) With ND 1204 on request

IK 5000



Connections to the IK 5000 are made via its D-sub connectors. Depending on the version, further connections are made through one, two or three additional slot covers. Please order the adapter cables necessary between the individual components separately.

		IK 5293	IK 5294	IK 5394-EG	IK 5394-3D	IK 5493	IK 5494-2D	IK 5494-3D	IK 5594
	Slots ¹⁾	2	2	3	4	3	4	4	4
	Location								
Encoders for X, Y, Z	IK	1 V _{PP} or TTL							
CNC outputs	IK	-	-	-	-	●	●	●	●
Foot switch	IK	●	●	●	●	●	●	●	●
Fiber-optic cable	Slot L	-	-	● ²⁾	-	● ²⁾	-	-	-
Touch probe³⁾	Slot 1	●	-	-	●	-	-	●	TP 200
Light control	Slot 1	-	-	-	●	-	●	●	●
Encoder for Q	Slot 2	-	1 V _{PP} or TTL						
Zoom	Slot 3	-	-	-	●	-	●	●	●
Video	PC	-	-	-	USB camera ⁴⁾	-	USB camera ⁴⁾	USB camera ⁴⁾	USB camera ⁴⁾

● = Available; - = Not available

¹⁾ Including IK; ²⁾ Connected directly to the IK PCB, special slot cover with cable guide included in delivery

³⁾ HEIDENHAIN touch probe or Renishaw touch probe; ⁴⁾ Connected to the USB port of the PC

Adapter cable		1 V _{PP}	TTL
Complete with D-sub connector (female), 15-pin (1 V _{PP}) or 9-pin (TTL), and 3-pin mini-DIN connector (female) For connecting the XYZ encoders and the foot switch to the IK 5000			
	For 3 axes XYZ and foot switch	540550-40	540550-10
	For 2 axes XY and foot switch	540540-24	540540-05
Complete with D-sub connector (female), 15-pin (1 V _{PP}) or 9-pin (TTL) For connecting the Q encoder to the IK 5000		540541-24	540541-05

Interfaces

Encoders

Digital readouts and PC card feature interfaces for connecting encoders from HEIDENHAIN. Other interfaces are available upon request. A distribution cable is necessary in order to attach the encoders to the IK 5000.

Pin layout $\sim 1V_{PP}$

Mating connector:
15-pin D-sub connector (male)

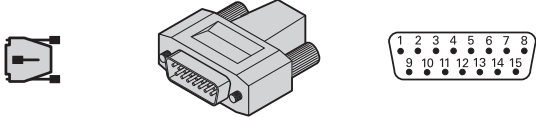

	Power supply				Incremental signals						Others
	4	12	2	10	1	9	3	11	14	7	5/6/8/ 13/15
$\sim 1V_{PP}$	U_P	Sensor U_P	0V	Sensor 0V	A+	A-	B+	B-	R+	R-	/

Cable shield connected to housing; U_P = power supply voltage

Sensor: The sensor line is connected in the encoder with the corresponding power line.

Vacant pins or wires must not be used!

Pin layout \square TTL

Mating connector:
9-pin D-sub connector (male)

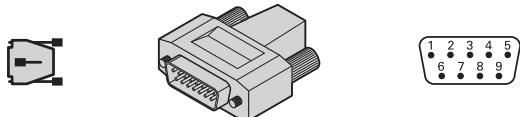



	Power supply		Incremental signals						Others
	7	6	2	3	4	5	9	8	1
\square TTL	U_P	0V	U_{a1}	$\overline{U_{a1}}$	U_{a2}	$\overline{U_{a2}}$	U_{a0}	$\overline{U_{a0}}$	/

Cable shield connected to housing; U_P = power supply voltage

Vacant pins or wires must not be used!

Pin layout of ND 2100G EnDat

8-pin coupling, M12								
	Power supply				Absolute position values			
	8	2	5	1	3	4	7	6
	U_P	Sensor U_P	0V	Sensor 0V	DATA	$\overline{\text{DATA}}$	CLOCK	$\overline{\text{CLOCK}}$
	Brown/Green	Blue	White/Green	White	Gray	Pink	Violet	Yellow

Cable shield connected to housing; U_P = power supply voltage

Sensor: The sensor line is connected in the encoder with the corresponding power line.

Vacant pins or wires must not be used!

The ND 287 digital readout can be equipped with a second encoder input.

Accessory for ND 287:

Encoder module

Input assembly for second encoder with
1 V_{PP}, 11 μA_{PP} or EnDat 2.2. interface
ID 654017-01

Pin layout of series ND 200 ~ 1 V_{PP}/~ 11 μA_{PP}/EnDat

Mating connector: 15-pin D-sub connector (male)															
	Power supply					Incremental signals						Absolute position values			
	4	12	2	10	6	1	9	3	11	14	7	5	13	8	15
$\sim 1V_{PP}$	U_P	Sensor U_P	0V	Sensor 0V	/	A+	A-	B+	B-	R+	R-	/	/	/	/
$\sim 11\mu A_{PP}$					Internal shield	I ₁₊	I ₁₋	I ₂₊	I ₂₋	I ₀₊	I ₀₋	/	/	/	/
EnDat						/	/	/	/	/	/	DATA	$\overline{\text{DATA}}$	CLOCK	$\overline{\text{CLOCK}}$

Shield on housing; U_P = power supply voltage

Sensor: The sensor line is connected in the encoder with the corresponding power line.

Vacant pins or wires must not be used!

Interfaces

Switching inputs/outputs on ND 287

Switching inputs

The ND 287 digital readout features many inputs for external operation and outputs for switching functions. The input can respond by pulse or make contact.

Exception: The switching inputs for transmitting measured values over the data interface are separate for contact and pulse.

The switching input E is active when a Low signal U_L is applied (contact or pulse to 0V).

Signal levels

- $0.5V \leq U_L \leq 0.9V$ at $I_L \leq 6\text{ mA}$
- $3.9V \leq U_H \leq 15.0V$
- $t_{\min} \geq 30\text{ ms}$

Zero reset/preset

Each axis can be set by an external signal to the display value zero or to a value stored in a parameter (SET).

External control of measurement series Switch display between MIN, MAX or DIFF

With a continuously applied Low signal at the corresponding switching input you activate the external control of measurement series. Starting a measurement series and switching to the MIN/MAX/DIFF display are controlled externally over additional switching inputs.

Ignoring reference mark signals

(disabling the reference pulse)
When the input is active, the readout ignores all reference mark signals. A typical application is for linear measurement through the lead screw and a rotary encoder.

Activating or deactivating REF mode

After switch-on or a power interruption, the digital readout can be switched externally to REF mode. The next signal then deactivates REF mode (switchover function).

Display with axis coupling

As an option, the ND 287 can have two encoder inputs. Using switching inputs, you can switch the display to individual measured values, sum, difference or any logical operation.

ND 287	
12 switching inputs	Reset, clear error message Datum setting Externally control measurement series or display of $X1^{1)}$ Start measurement series or display of $f(X1, X2)^{1)}$ Display minimum MIN or display of $X2^{1)}$ Display maximum MAX or display of $X1 + X2^{1)}$ Display maximum DIFF or display of $X1 + X2^{1)}$ Measured value output (pulse) Measured value output (contact) Ignore reference mark signals (input X1) Ignore reference mark signals (input X2) Activating or deactivating REF mode
6 switching outputs	Display value is zero Measured value \geq switching limit A1 Measured value \leq switching limit A2 Measured value $>$ upper sorting limit Measured value $<$ lower sorting limit Errors

¹⁾ Also selectable by parameter

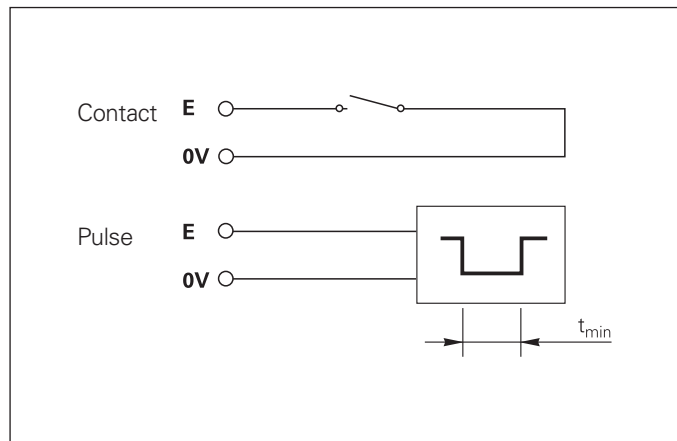

Switching outputs

The ND 287 features open-collector outputs that switch to 0 V (= active Low).

Delay of signal output:

$t_v \leq 20 \text{ ms}$

Signal levels

$U_L \leq 0.4 \text{ V}$ at $I_L \leq 100 \text{ mA}$

$U_H \leq 32 \text{ V}$ at $I_H \leq 10 \mu\text{A}$

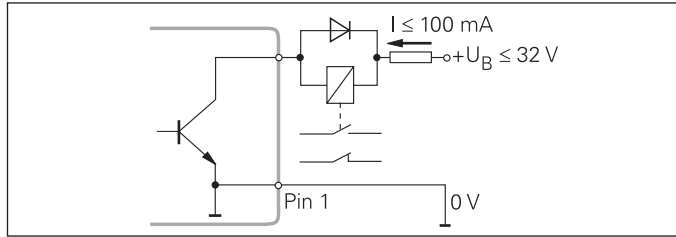

Trigger points (in actual value mode)

When the measured value reaches trigger points defined by parameter, the corresponding output becomes active. Up to two trigger points can be defined.

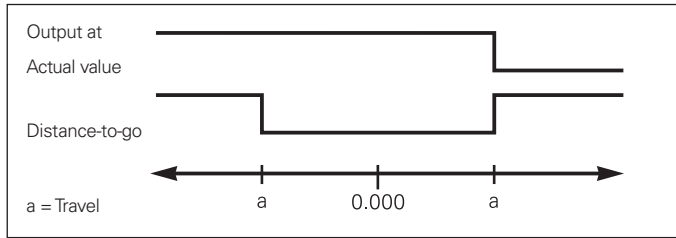

Switch-off ranges

(in distance-to-go mode)

In the distance-to-go mode the trigger points function as switch-off ranges. They are located symmetrically around the display value 0.

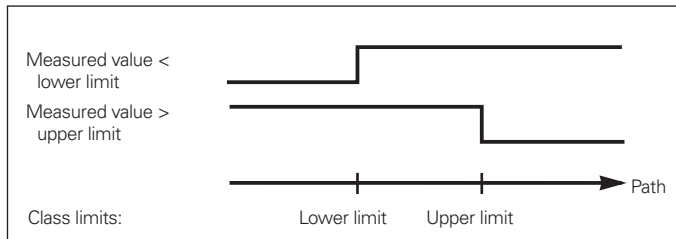

Sorting limits

When the measured value exceeds the limits defined via parameters, the corresponding outputs become active.

Trigger signal for error

The ND 200 series readouts constantly monitor the measuring signals, the input frequency, the data output, etc. for errors, and report errors as they occur with error messages. If an error occurs that may distort the measurement or corrupt the data, the readout activates a switching output. This feature allows monitoring of automated processes.

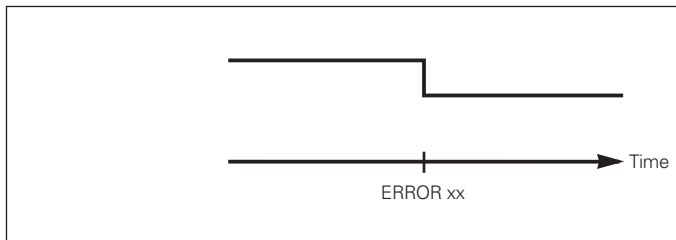

Zero crossover

At the display value "zero," the corresponding output becomes active. The minimum signal duration is 180 ms.

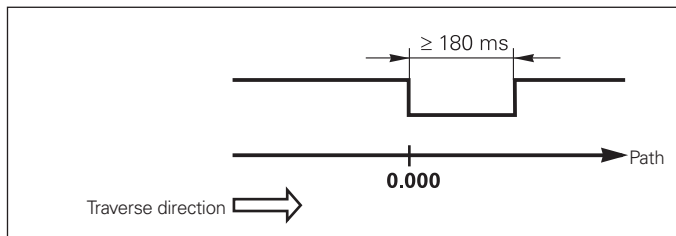

Software

QUADRA-CHEK Wedge

QUADRA-CHEK Wedge software

For communication between the ND 1000/ND 2000 and PC ID 709141-01

The QUADRA-CHEK Wedge software simplifies communication between an ND 1000/ND 2000 and a Windows-based PC. The measured values are transmitted from the digital readout to the PC via a RS-232-C connection, and are written directly to an Excel table, where the data can be edited, saved and printed. A suitable RS-232-C cable is included with QUADRA-CHEK Wedge (cable length: 3 m).

System requirements

- Windows XP, Vista or 7 (32 bits)
- Internet Explorer 6.0 or higher
- Excel 2003 or later
- Windows user rights: Administrator

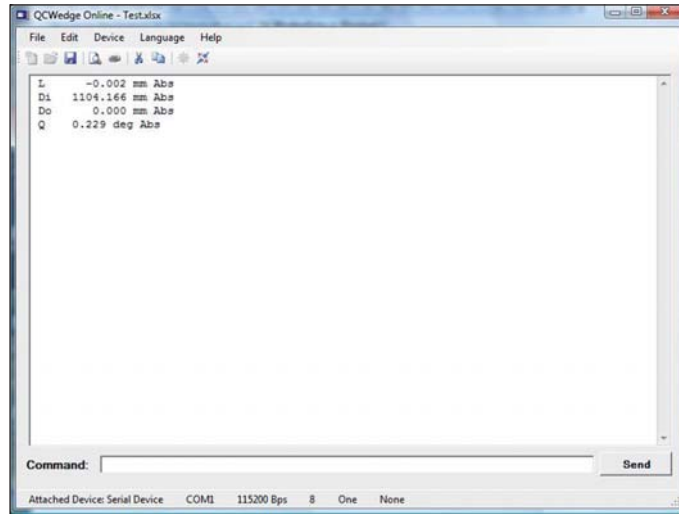

The values measured by the digital readout are transmitted to the PC...

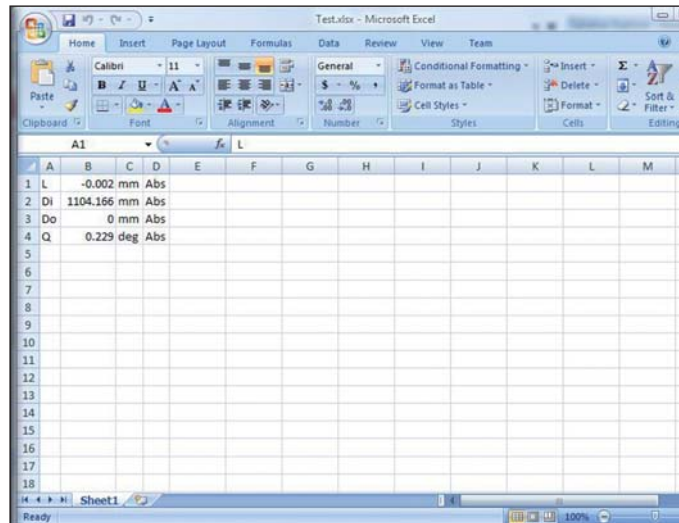

...and can be saved in an Excel table.

HEIDENHAIN

DR. JOHANNES HEIDENHAIN GmbH

Dr.-Johannes-Heidenhain-Straße 5

83301 Traunreut, Germany

☎ +49 8669 31-0

FAX +49 8669 5061

E-mail: info@heidenhain.de

www.heidenhain.de

Vollständige und weitere Adressen siehe www.heidenhain.de
For complete and further addresses see www.heidenhain.de

DE	HEIDENHAIN Vertrieb Deutschland 83301 Traunreut, Deutschland ☎ 08669 31-3132 FAX 08669 32-3132 E-Mail: hd@heidenhain.de	DK	TPTEKNIK A/S 2670 Greve, Denmark www.tp-gruppen.dk	NO	HEIDENHAIN Scandinavia AB 7300 Orkanger, Norway www.heidenhain.no
	HEIDENHAIN Technisches Büro Nord 12681 Berlin, Deutschland ☎ 030 54705-240	ES	FARRESA ELECTRONICA S.A. 08028 Barcelona, Spain www.farresa.es	PH	Machinebanks` Corporation Quezon City, Philippines 1113 E-mail: info@machinebanks.com
	HEIDENHAIN Technisches Büro Mitte 08468 Heinsdorfergrund, Deutschland ☎ 03765 69544	FI	HEIDENHAIN Scandinavia AB 02770 Espoo, Finland www.heidenhain.fi	PL	APS 02-489 Warszawa, Poland www.apserwis.com.pl
	HEIDENHAIN Technisches Büro West 44379 Dortmund, Deutschland ☎ 0231 618083-0	FR	HEIDENHAIN FRANCE sarl 92310 Sèvres, France www.heidenhain.fr	PT	FARRESA ELECTRÓNICA, LDA. 4470 - 177 Maia, Portugal www.farresa.pt
	HEIDENHAIN Technisches Büro Südwest 70771 Leinfelden-Echterdingen, Deutschland ☎ 0711 993395-0	GB	HEIDENHAIN (G.B.) Limited Burgess Hill RH15 9RD, United Kingdom www.heidenhain.co.uk	RO	HEIDENHAIN Reprezentantă Romania Braşov, 500338, Romania www.heidenhain.ro
	HEIDENHAIN Technisches Büro Südost 83301 Traunreut, Deutschland ☎ 08669 31-1345	GR	MB Milionis Vassilis 17341 Athens, Greece www.heidenhain.gr	RS	Serbia → BG
AR	NAKASE SRL. B1653AOX Villa Ballester, Argentina www.heidenhain.com.ar	HR	Croatia → SL	RU	OOO HEIDENHAIN 125315 Moscow, Russia www.heidenhain.ru
AT	HEIDENHAIN Techn. Büro Österreich 83301 Traunreut, Germany www.heidenhain.de	HU	HEIDENHAIN Kereskedelmi Képviselet 1239 Budapest, Hungary www.heidenhain.hu	SE	HEIDENHAIN Scandinavia AB 12739 Skärholmen, Sweden www.heidenhain.se
AU	FCR Motion Technology Pty. Ltd Laverton North 3026, Australia E-mail: vicsales@fcrmotion.com	ID	PT Servitama Era Toolsindo Jakarta 13930, Indonesia E-mail: ptset@group.gts.co.id	SG	HEIDENHAIN PACIFIC PTE LTD. Singapore 408593 www.heidenhain.com.sg
BA	Bosnia and Herzegovina → SL	IL	NEUMO VARGUS MARKETING LTD. Tel Aviv 61570, Israel E-mail: neumo@neumo-vargus.co.il	SK	KOPRETINA TN s.r.o. 91101 Trenčin, Slovakia www.kopretina.sk
BE	HEIDENHAIN NV/SA 1760 Roosdaal, Belgium www.heidenhain.be	IN	HEIDENHAIN Optics & Electronics India Private Limited Chetpet, Chennai 600 031, India www.heidenhain.in	SL	Posredništvo HEIDENHAIN NAVO d.o.o. 2000 Maribor, Slovenia www.heidenhain-hubl.si
BG	ESD Bulgaria Ltd. Sofia 1172, Bulgaria www.esd.bg	IT	HEIDENHAIN ITALIANA S.r.l. 20128 Milano, Italy www.heidenhain.it	TH	HEIDENHAIN (THAILAND) LTD Bangkok 10250, Thailand www.heidenhain.co.th
BR	DIADUR Indústria e Comércio Ltda. 04763-070 – São Paulo – SP, Brazil www.heidenhain.com.br	JP	HEIDENHAIN K.K. Tokyo 102-0083, Japan www.heidenhain.co.jp	TR	T&M Mühendislik San. ve Tic. LTD. ŞTİ. 34728 Ümraniye-Istanbul, Turkey www.heidenhain.com.tr
BY	Belarus GERTNER Service GmbH 50354 Huerth, Germany www.gertnergroup.com	KR	HEIDENHAIN K.K. Gasan-Dong, Seoul, Korea 153-782 www.heidenhain.co.kr	TW	HEIDENHAIN Co., Ltd. Taichung 40768, Taiwan R.O.C. www.heidenhain.com.tw
CA	HEIDENHAIN CORPORATION Mississauga, Ontario L5T2N2, Canada www.heidenhain.com	ME	Montenegro → SL	UA	Gertner Service GmbH Büro Kiev 01133 Kiev, Ukraine www.gertnergroup.com
CH	HEIDENHAIN (SCHWEIZ) AG 8603 Schwerzenbach, Switzerland www.heidenhain.ch	MK	Macedonia → BG	US	HEIDENHAIN CORPORATION Schaumburg, IL 60173-5337, USA www.heidenhain.com
CN	DR. JOHANNES HEIDENHAIN (CHINA) Co., Ltd. Beijing 101312, China www.heidenhain.com.cn	MX	HEIDENHAIN CORPORATION MEXICO 20235 Aguascalientes, Ags., Mexico E-mail: info@heidenhain.com	VE	Maquinaria Diekmann S.A. Caracas, 1040-A, Venezuela E-mail: purchase@diekmann.com.ve
CZ	HEIDENHAIN s.r.o. 102 00 Praha 10, Czech Republic www.heidenhain.cz	MY	ISOSERVE Sdn. Bhd 56100 Kuala Lumpur, Malaysia E-mail: isoserve@po.jaring.my	VN	AMS Co. Ltd HCM City, Vietnam E-mail: davidgoh@amsvn.com
		NL	HEIDENHAIN NEDERLAND B.V. 6716 BM Ede, Netherlands www.heidenhain.nl	ZA	MAFEMA SALES SERVICES C.C. Midrand 1685, South Africa www.heidenhain.co.za

