



HEIDENHAIN

Montageanleitung
Mounting Instructions
Instructions de montage
Istruzioni di montaggio
Instrucciones de montaje

LS 1679

2/2005

 DIN EN 100 015 - 1
CECC 00015 - 1

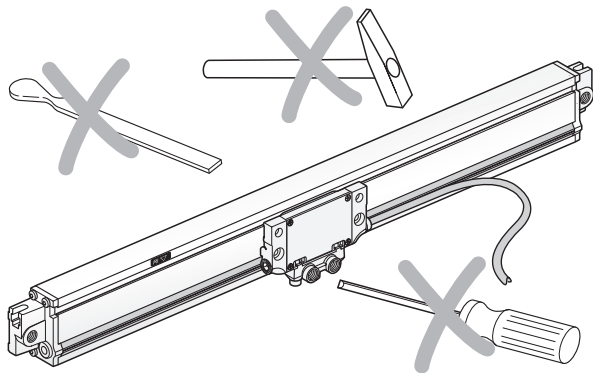
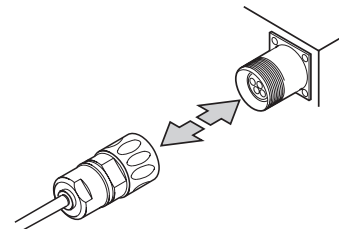
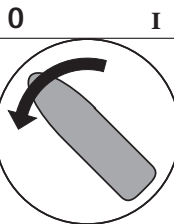

Maße in mm
Dimensions in mm
Cotes en mm
Dimensioni in mm
Dimensiones en mm

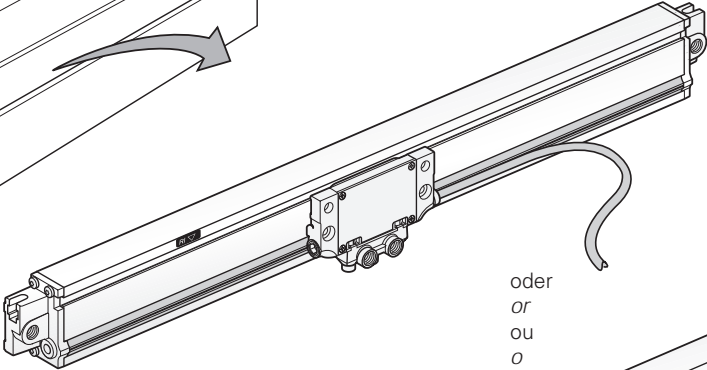
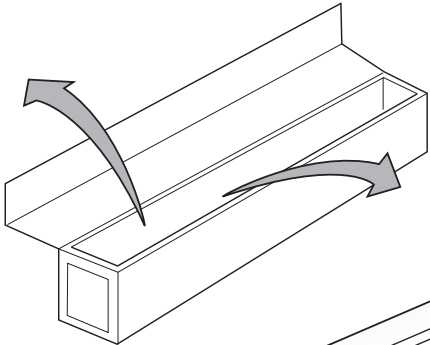
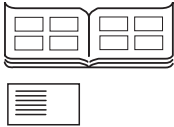

oder
or
ou
o
o

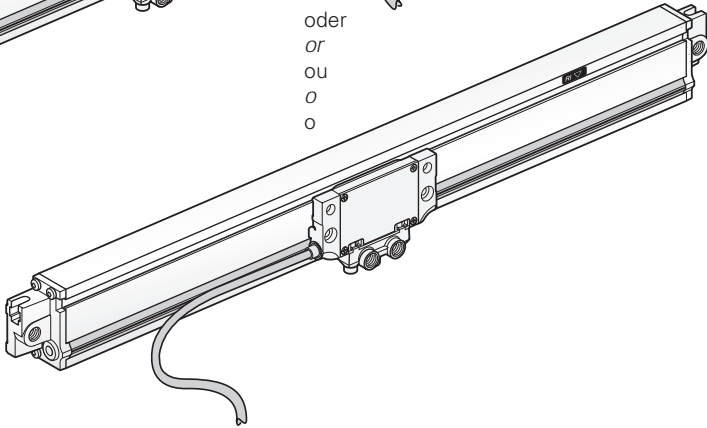

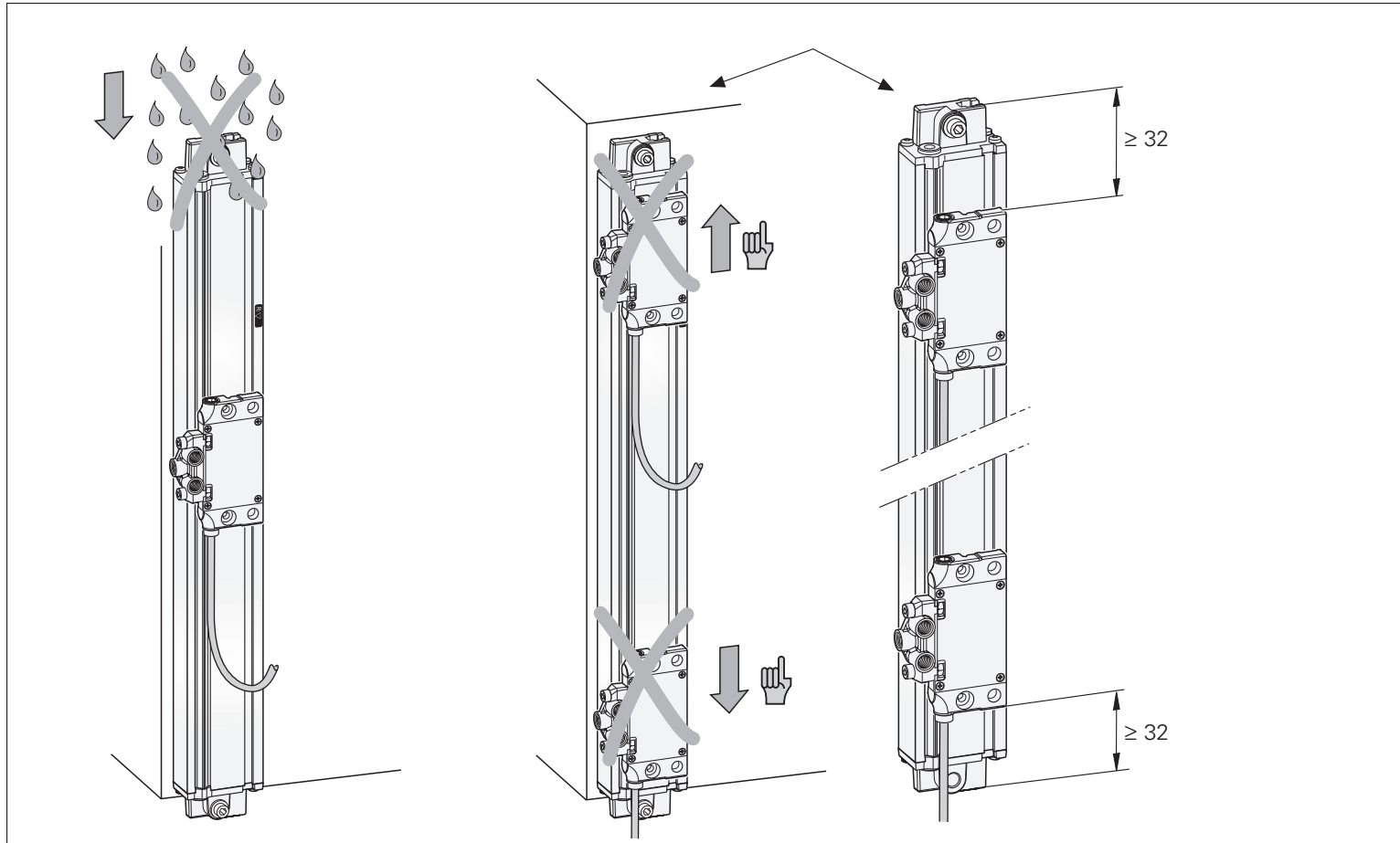

Avvertenze per il montaggio · Indicaciones para el montaje

Keine Oberflächenbehandlung zulässig. (Blanke Flächen).

No surface treatment permissible (blank surfaces).

Aucun traitement des surfaces n'est autorisé. (surfaces nues).

Non trattare la superficie (superfici lavorate non rivestite).

No se permite el tratamiento de la superficie (superficies en blanco).

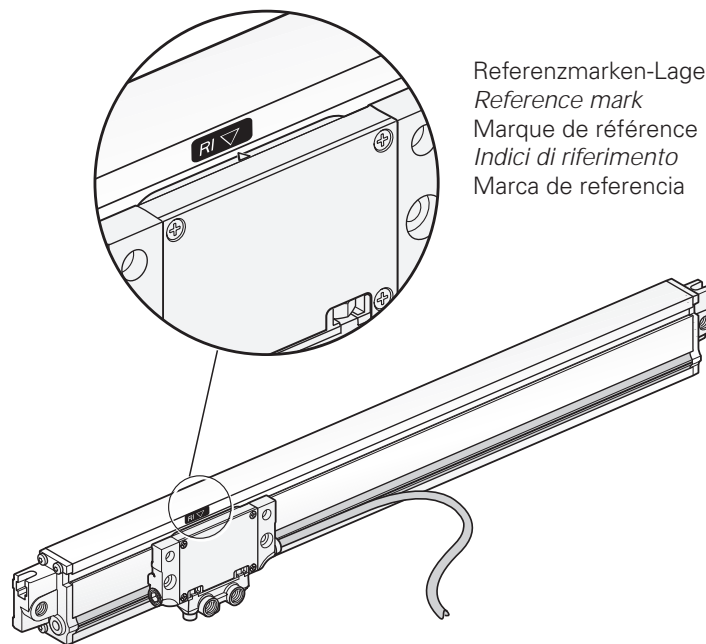
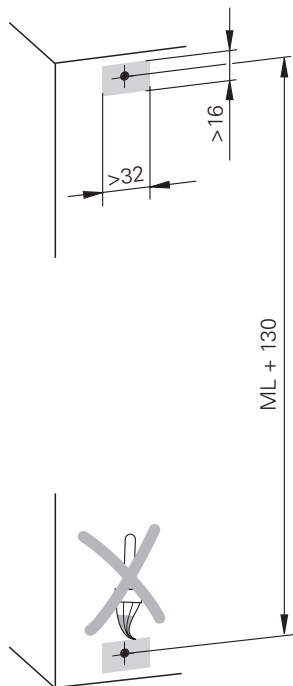

F = Maschinenführung
Machine guideway
Guidage de la machine
Guida della macchina
Guía de la máquina

P = Messpunkte zum Ausrichten
Gauging points for alignment
Points de mesure pour dé gauchissage
Punti di misura per allineamento
Puntos medición alineamiento

Ⓜ = Referenzmarken
Reference mark
Marque de référence
Indici di riferimento
Marca de referencia

Ⓚ = Kundenseitige Anschlussmaße
Required mating dimensions
Conditions requises pour le montage
Dimensioni di collegamento lato cliente
Cotas de montaje requeridas

Ⓢ = Beginn der Messlänge ML
Begin. of meas. length ML
Début longueur utile ML
Inizio lunghezza di misura ML
Comienzo longitud útil ML

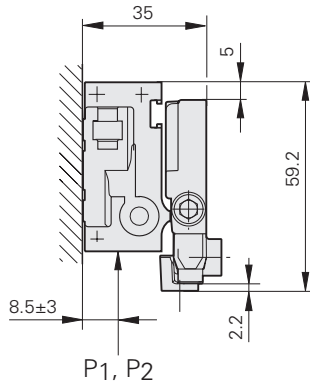

Anbau des Maßstabs · *Mounting the Scale* · Montage de la règle de mesure · *Montaggio della riga* · Montaje de la regla

① ② = Montage-Möglichkeiten
Mounting possibilities
 Options de montage
Possibilità di montaggio
 Posibilidades de montaje

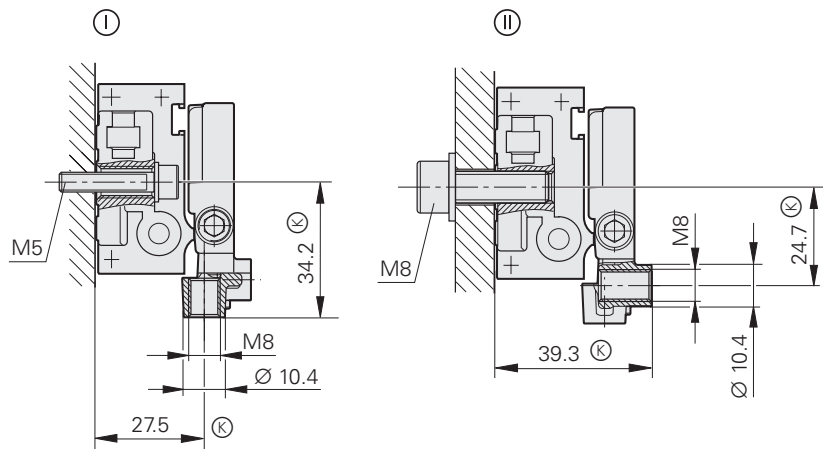

Ⓚ = Kundenseitige Anschlussmaße
Required mating dimensions
 Conditions requises pour le montage
Dimensioni di collegamento lato cliente
 Cotas de montaje requeridas

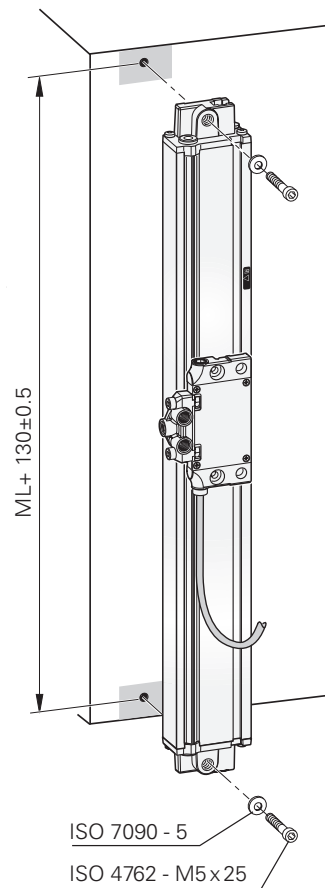

Ausrichten · *Aligment* · *Alignement* · *Allineamento* · *Alinear*

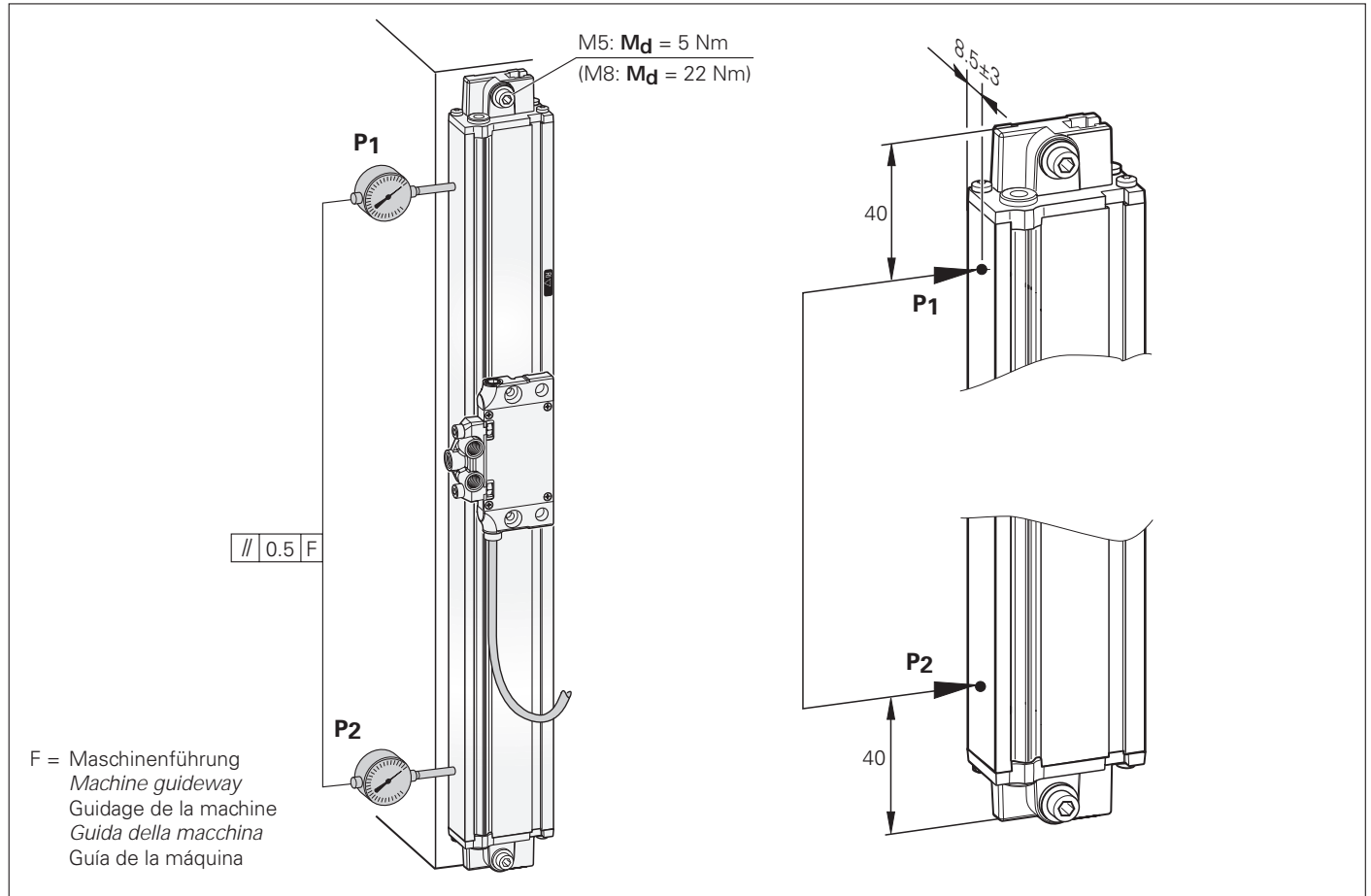

Zusätzliche
Anbaumöglichkeiten

· *Additional
mounting options*

· Possibilités de
montage supplémentaires

· *Altre possibilità
di montaggio*

· Posibilidades de
montaje adicionales

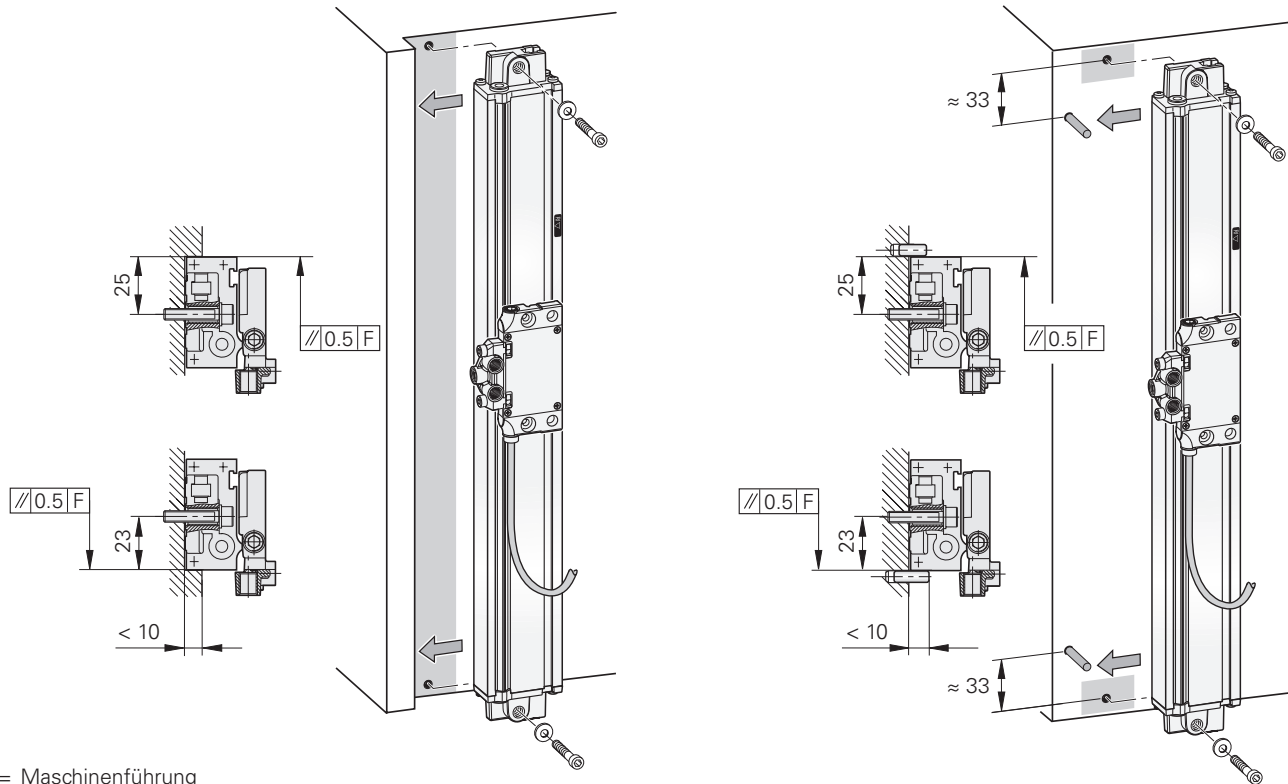

F = Maschinenführung
Machine guideway
Guidage de la machine
Guida della macchina
Guía de la máquina

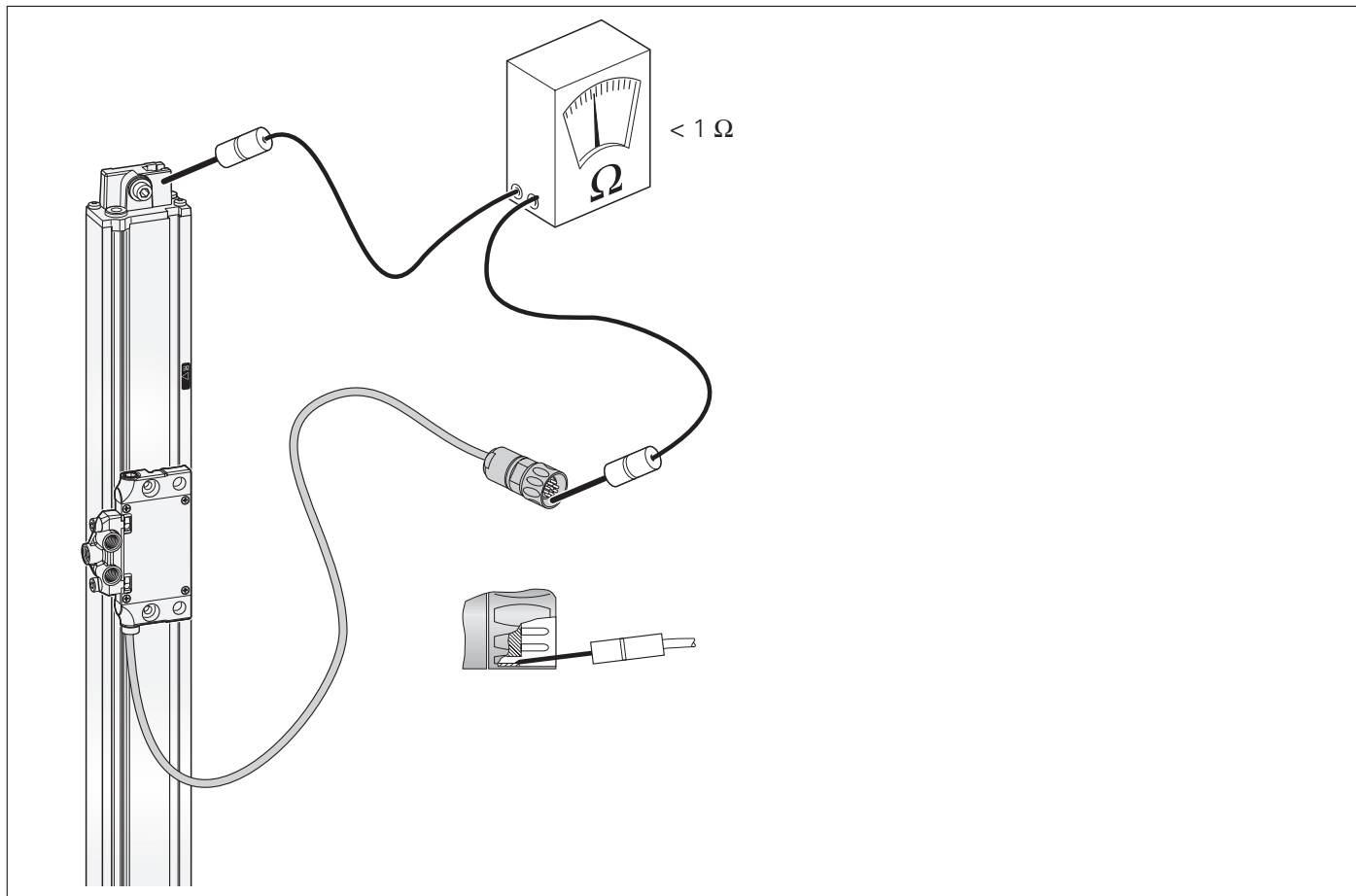

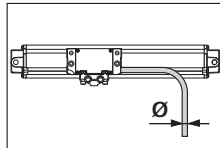
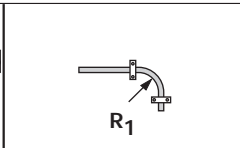
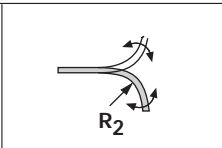
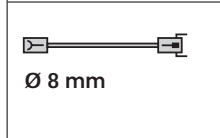
		
<p>Ø 4.3 mm</p>	<p>$R_1 \geq 22 \text{ mm}$</p>	<p>$R_2 \geq 44 \text{ mm}$</p>
 <p>Ø 8 mm</p>	<p>$R_1 \geq 40 \text{ mm}$</p>	<p>$R_2 \geq 100 \text{ mm}$</p>

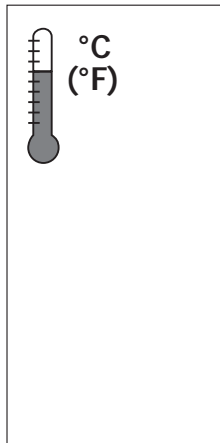
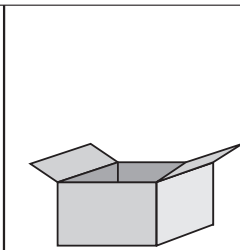
	 <p>-20 ... 70 °C (- 4 ... 158 °F)</p>
---	---

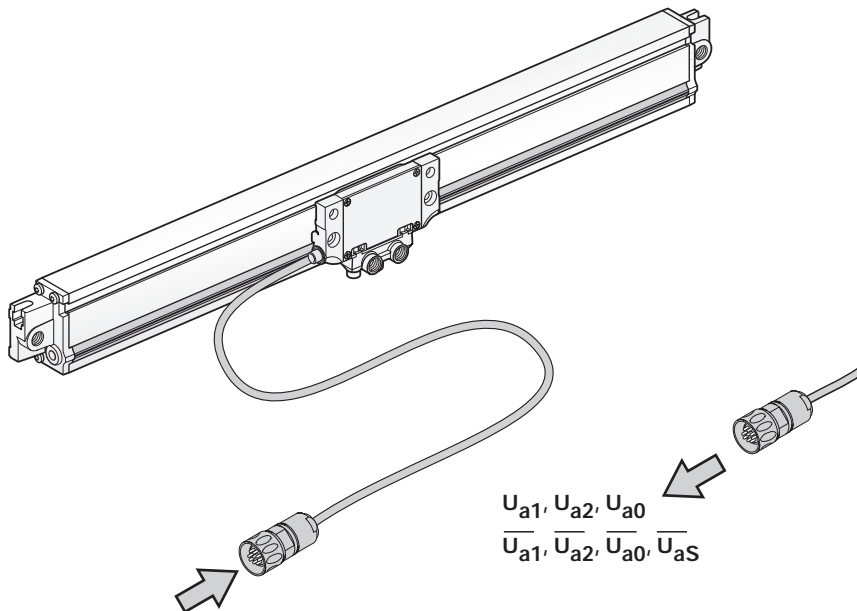

U_{a1}, U_{a2}, U_{a0}
 $\overline{U}_{a1}, \overline{U}_{a2}, \overline{U}_{a0}, \overline{U}_{aS}$

$U_p = 5V \pm 5\%$

max. 120 mA (ohne Last, *without load*, *sans charge*, *senza carico*, *sin carga*)

max. 200 mA (mit Abschlusswiderstand 120 Ω , *with 120 Ω terminating resistor*, *avec résistance de charge 120 Ω* , *con resistenza di carico di 120 Ω*)



EN 50 178/4.98; 5.2.9.5

IEC 364-4-41: 1992; 411(PELV/SELV)

(siehe, *see*, *voir*, *vedi*, véase
HEIDENHAIN D 231 929)

Messschritt <i>Measuring step</i> Pas de mesure <i>Passo di misura</i> Paso de medición	1 μm	5 μm
a =	0.8 μs	1.6 μs

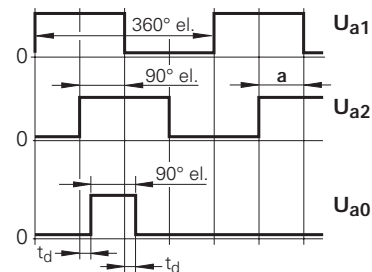

$|t_d| \leq 0.1 \mu\text{s}$

Elektrischer Anschluss · *Electrical Connection* · Raccordement électrique · *Collegamento elettrico* · Conexión eléctrica



Schirm auf Gehäuse
Shield on housing
 Blindage sur boîtier
Schermo sulla carcassa
 Blindaje a carcasa

5	6	8	1	3	4	12	10	2	11	7	/
U_{a1}	\overline{U}_{a1}	U_{a2}	\overline{U}_{a2}	U_{a0}	\overline{U}_{a0}	5 V U_p	0 V U_N	5 V sensor	0 V sensor	\overline{U}_{aS}	/
braun <i>brown</i> brun <i>marrone</i> marrón	grün <i>green</i> vert <i>verde</i> verde	grau <i>gray</i> gris <i>grigio</i> gris	rosa <i>pink</i> rose <i>rosa</i> rosa	rot <i>red</i> rouge <i>rosso</i> rojo	schwarz <i>black</i> noir <i>nero</i> negro	braun/grün <i>brown/green</i> brun/vert <i>marrone/verde</i> marron/verde	weiß/grün <i>white/green</i> blanc/vert <i>bianco/verde</i> blanco/verde	blau <i>blue</i> bleu <i>azzurro</i> azul	weiß <i>white</i> blanc <i>bianco</i> blanco	violett <i>violet</i> violet <i>viola</i> violeta	gelb <i>yellow</i> jaune <i>giallo</i> amarillo

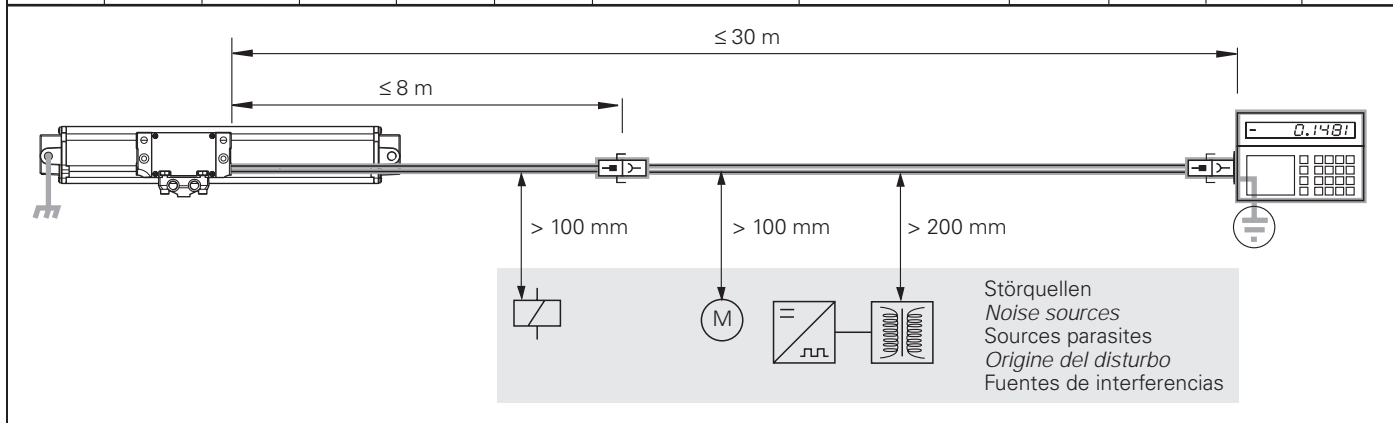

Elektrischer Anschluss · *Electrical Connection* · Raccordement électrique · *Collegamento elettrico* · Conexión eléctrica

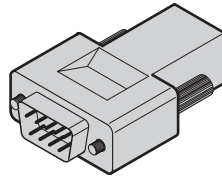
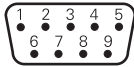

Schirm auf Gehäuse
Shield on housing
 Blindage sur boîtier
Schermo sulla carcassa
 Blindaje a carcasa

3	8	2	7	1	6	9	5	4
T1	$\overline{T1}$	T2	$\overline{T2}$	T0	$\overline{T0}$	+5 V	0 V	/
U_{a1}	$\overline{U_{a1}}$	U_{a2}	$\overline{U_{a2}}$	U_{a0}	$\overline{U_{a0}}$	5 V U_P	0 V U_N	/
braun <i>brown</i> brun <i>marrone</i> marrón	grün <i>green</i> vert <i>verde</i> verde	grau <i>gray</i> gris <i>grigio</i> gris	rosa <i>pink</i> rose <i>rosa</i> rosa	rot <i>red</i> rouge <i>rosso</i> rojo	schwarz <i>black</i> noir <i>nero</i> negro	braun/grün + blau <i>brown/green + blue</i> brun/vert + bleu <i>marrone/verde + azzurro</i> marron/verde + azul	weiß/grün + weiß <i>white/green + white</i> blanc/vert + blanc <i>bianco/verde + bianco</i> blanco/verde + blanco	/

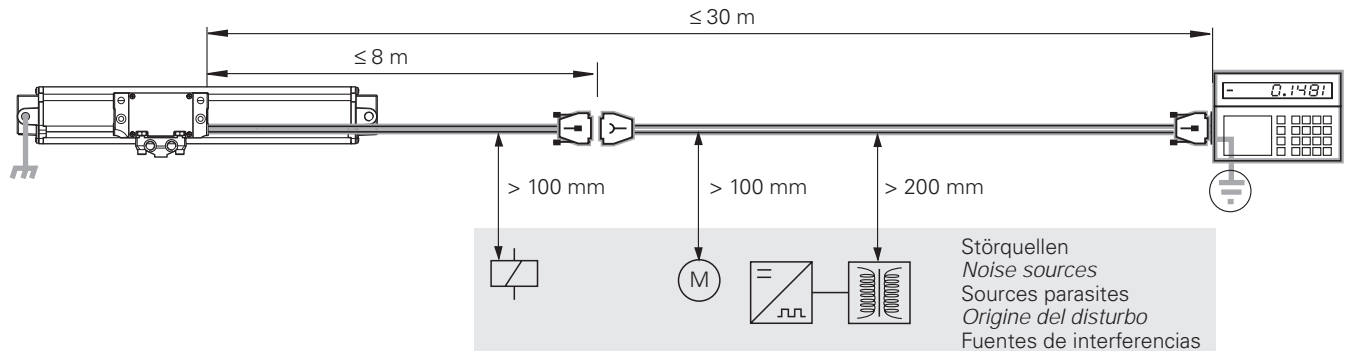

Montage der Kupplungsstange
Mounting of the coupling rod
Montage de la tige de liaison
Montaggio della barra di accoppiamento
Montaje de la barra de acoplamiento

Id.-Nr. 538 768-01



Im Lieferumfang enthalten
Included in delivery
Contenu dans la fourniture
Standard di fornitura
Elementos suministrados

Abmessungen · Dimensions · Dimensions · Dimensioni · Dimensiones

mm



DIN ISO 8015

ISO 2768 - m H

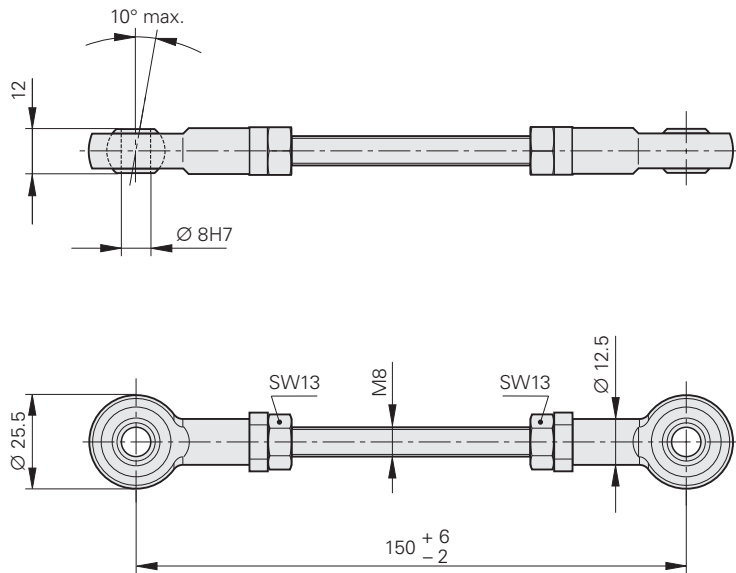

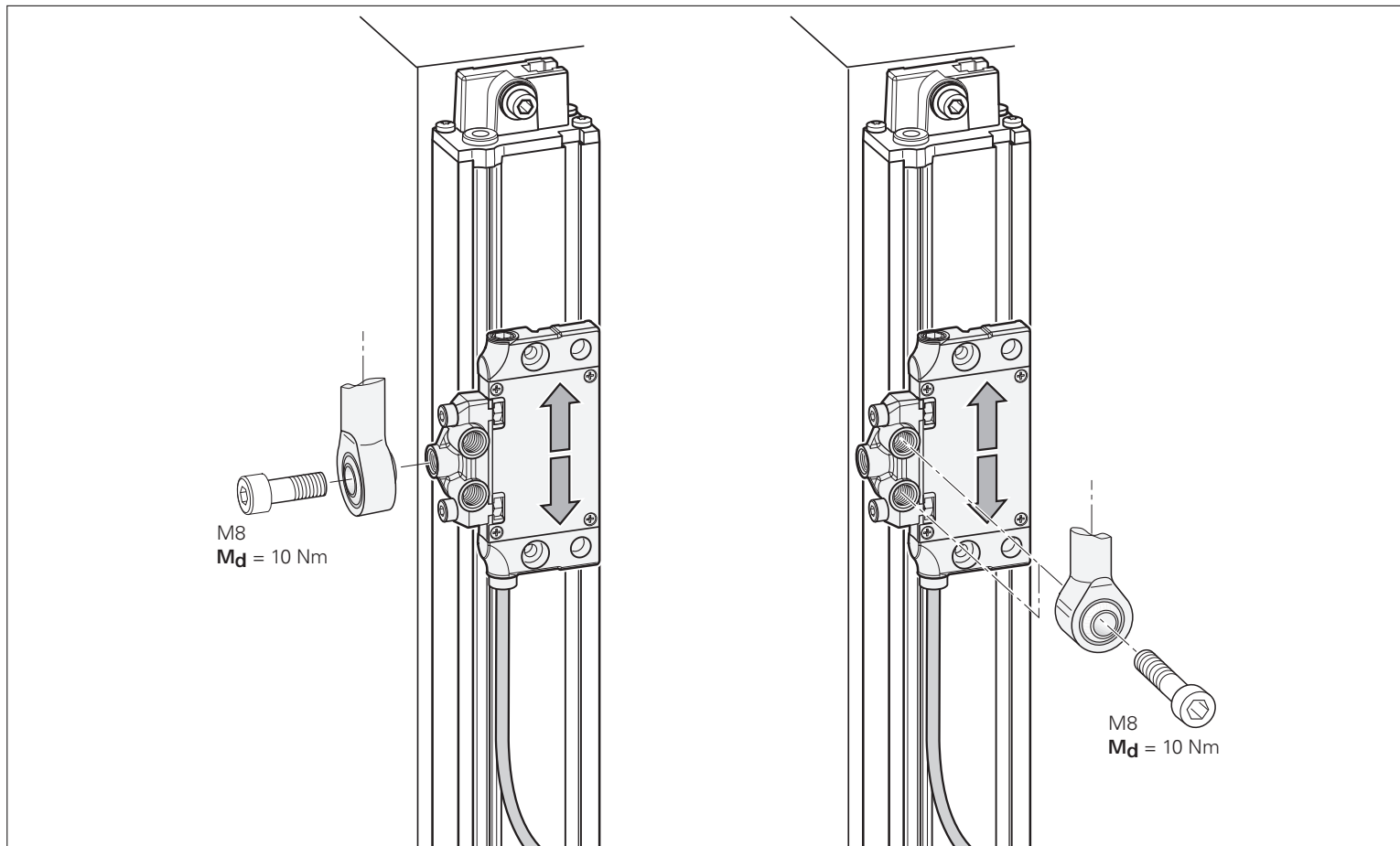

Achtung: Auf max. Winkelauslenkung achten!
Caution: Observe maximum angular deflection!
Attention: Tenir compte du déport angulaire max.
Attenzione: prestare attenzione al massimo angolo di apertura
Atención: ¡Prestar atención al desplazamiento angular máximo!

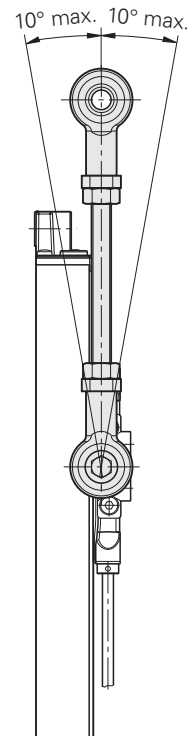
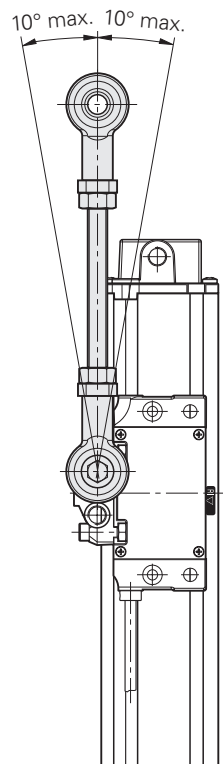
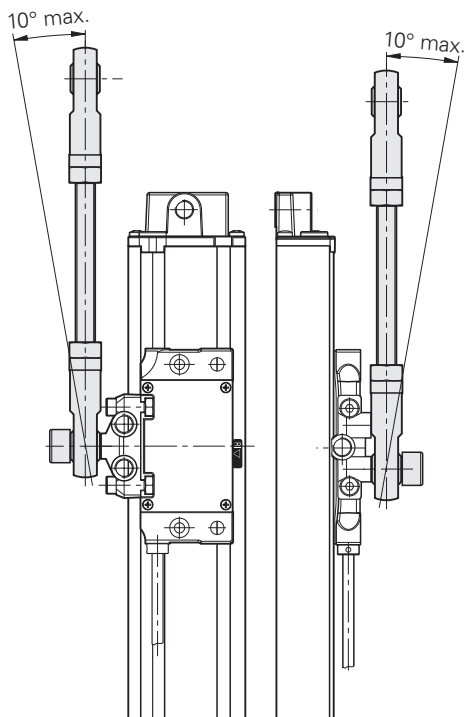

HEIDENHAIN

DR. JOHANNES HEIDENHAIN GmbH

Dr.-Johannes-Heidenhain-Straße 5

83301 Traunreut, Germany

☎ +49 (86 69) 31-0

FAX +49 (86 69) 50 61

e-mail: info@heidenhain.de

Technical support FAX +49 (86 69) 31-10 00

Measuring systems ☎ +49 (86 69) 31-31 04

e-mail: service.ms-support@heidenhain.de

TNC support ☎ +49 (86 69) 31-31 01

e-mail: service.nc-support@heidenhain.de

NC programming ☎ +49 (86 69) 31-31 03

e-mail: service.nc-pgm@heidenhain.de

PLC programming ☎ +49 (86 69) 31-31 02

e-mail: service.plc@heidenhain.de

Lathe controls ☎ +49 (7 11) 95 28 03-0

e-mail: service.hsf@heidenhain.de

www.heidenhain.de

Ve 00

532 254-91 · 10 · 4/2005 · H · Printed in Germany

Änderungen vorbehalten · *Subject to change without notice* · Sous réserve de modifications · *Con riserva di modifiche* · Sujeto a modificaciones

