

RCU10 real time quadrature compensation system

The RCU10 real time quadrature compensation system overcomes environmental error sources in linear motion systems to improve process accuracy and repeatability.

The RCU10 monitors a machine's ambient environment via a series of sensors and uses advanced digital signal processing to perform real time compensation on the position feedback signals. The unit provides the corrected feedback signals to the motion controller in either RS422 digital AquadB or analogue sine / cosine 1 Vpp formats.

The factory calibrated sensors can be linked via a network and optional sensor distribution box. Each sensor is configured to a unique network address to enable interrogation by any compensator within multi-axis configurations.

Configuration of the RCU10 is achieved via an RS232 link to a PC running the Renishaw RCU10-CS-XX configuration software. This enables the user to select the mode of compensation and define axis specific parameters (input resolution, output resolution, output format etc).



The RCU10 can provide:

- Refractive index compensation for Renishaw laser encoders, using air pressure and temperature sensors.
- Scale expansion compensation for incremental linear encoders, using material temperature sensors.
- Thermal expansion compensation of machine structure using material temperature sensors.
- Work piece thermal expansion compensation, using material temperature sensors.

General outline and dimensions

Dimensions in mm (inches)

Overall dimensions:

Height: 42 (1.65)
 Length: 350 (13.78)
 Width: 133.5 (5.25)

Fixing:

The RCU10 has DIN rail compatible mounting brackets and can be mounted in any orientation.

2 off M6 x 1.0 x 15 mm* or
 1/4-20-UNC x 5/8 cap head screws*

*Not supplied

General information:

Weight 2 kg
 EMC compliance BS EN 61326
 FCC 47 CFR PART 15J

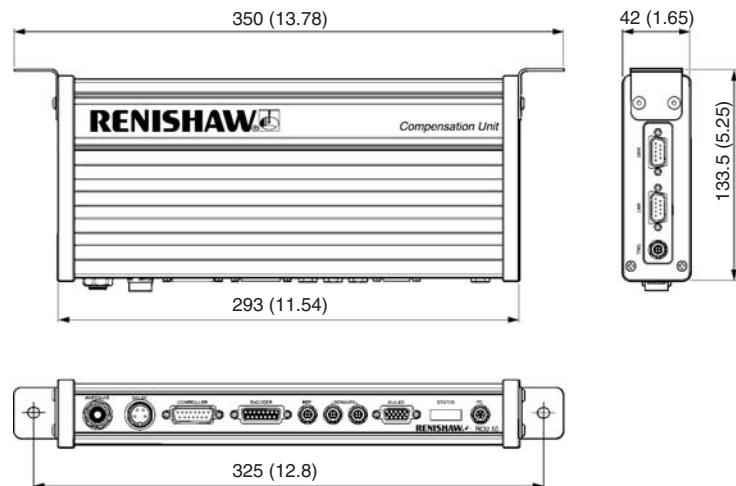

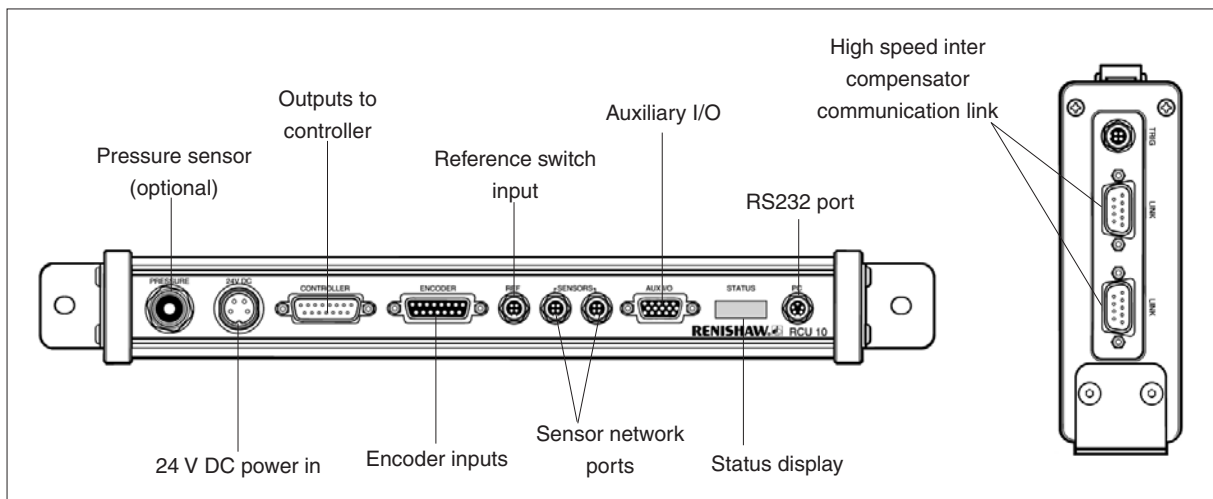

RCU10 power supply

Status	Voltage	Current	Power
Operational	24 V \pm 2 V	< 0.25 A*	6 W

*with up to 8 sensors

Operating environment

Pressure	Normal atmospheric (600-1150 millibars)
Humidity	0-95% RH (non-condensing)
Temperature	0 °C to 50 °C
Sealing	IP40

Performance overview

Input resolutions	10 nm to 5 μ m (digital only)
Output resolutions	Digital 10 nm to 5 μ m Analogue 20 μ m to 100 μ m
Accuracy**	\pm 1 ppm (refractive index compensation only)* \pm 2 ppm (with 10 ppm/°C material compensation)
Maximum velocity	5 m/s for resolutions > 400 nm 0.2 m/s at 10 nm resolution
Propagation delay	< 1 μ s (digital output) < 2 μ s (analogue output)
Output update rate	20 / 10 / 5 / 2.5 MHz (digital) 10 MHz (analogue)
Input sample rate	40 / 20 / 10 / 5 / 2.5 MHz
Compensation update rate	200 μ s

* Plus the greater of \pm 3 input counts and \pm 1 output counts for digital outputs and a further velocity dependent following error for some analogue outputs.

**This assumes a working atmospheric environment that falls within the range as defined in the sensor data opposite.

RCU10 input signals

Digital quadrature input*

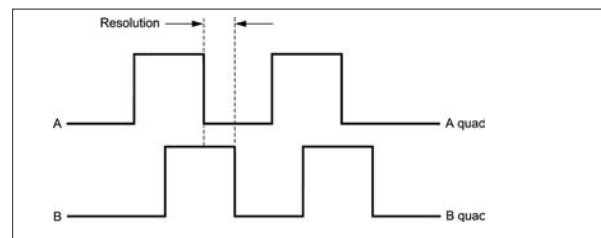

RCU10 output signals

Digital incremental*

RS422 differential line driver outputs

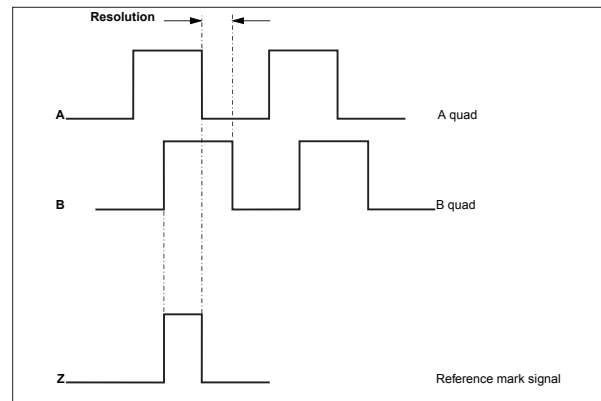

Analogue incremental*

1 Vpp differential sine and cosine line driver outputs

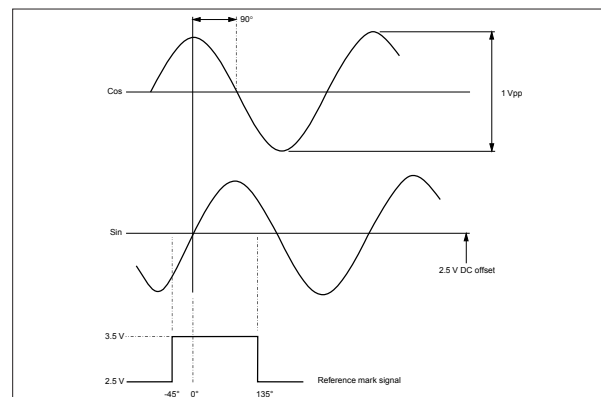

*Only one side of differential signals is shown for clarity

Environmental sensors

In air, the wavelength of light is a function of the refractive index, which is dependent on temperature, pressure and, to a lesser extent, humidity. To compensate for refractive index variations, the RCU10 system has an optional internal air pressure sensor and remote air temperature sensors, to accurately monitor these parameters in real time. A humidity value can be entered manually via the configuration software if required.

Material temperature sensors are also available to provide thermal expansion compensation for incremental linear encoders, machine structure and work pieces.

Air temperature sensor

Dimensions in mm (inches)

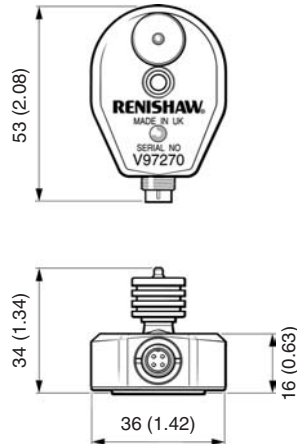

Accuracy	±0.2 °C (k=2)
Measurement range	0 °C to 40 °C
Resolution	0.01 °C
Update rate	1 Hz
Fixing	Magnetic or screw
Cable*	5 m cable supplied Extensions available Armoured version available
Sealing	IP67

*Cable must be ordered separately

Material temperature sensor

Dimensions in mm (inches)

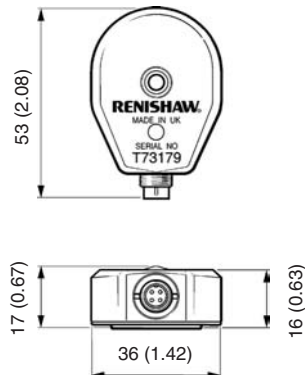

Accuracy	±0.1 °C
Measurement range	0 °C to 55 °C
Resolution	0.01 °C
Update rate	1 Hz
Fixing	Magnetic, screw or vacuum
Cable*	5 m cable supplied Extensions available
Sealing	IP67

*Cable must be ordered separately

Air pressure sensor

This optional sensor is located inside the RCU10 unit.

Accuracy	±2.0 mB (k=2)
Measurement range	600 mB to 1150 mB
Resolution	0.2 mB
Update rate	1 Hz

Sensor status LED information

LED status	Sensor status
Slow green flashes	Sensor functional
Fast green flashes	Sensor accessed
Slow red flashes	Sensor error*
Fast red flashes	Communication error*

*One red flash on power up

Sensor distribution box

The RCU10-DB-XX distribution box allows a network of up to four sensors to be connected to each sensor port of the RCU10 compensator. A maximum of eight sensors per RCU10 can be used with a maximum of 32 in a multi-axis system.

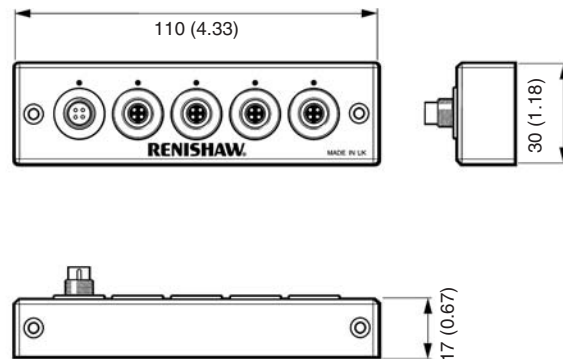

Dimensions in mm (inches)

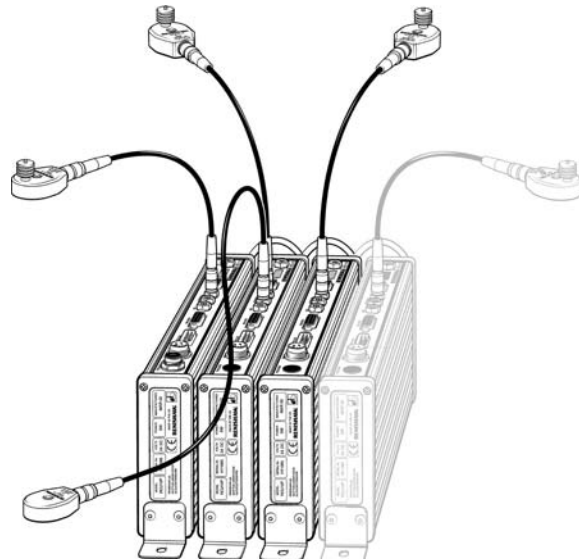

A typical multi-axis configuration for laser encoder compensation

A maximum of six RCU10 compensation units can be used in a system.

Compensation software

The RCU10-CS-XX software enables a wide range of parameters within the compensator to be configured to match the specific requirements of the application. Users with the software suite installed on their PC - and appropriate access rights - can extract and amend all relevant information from within the compensator system.

The minimum PC specification recommended to run the RCU10-CS-XX software is:

- 200 MHz Pentium processor
- 20 MB RAM available for RCU10-CS
- 40 MB hard drive space
- Windows 98, 2000, NT or XP operating system
- 800 x 600 screen resolution
- 16-bit colour
- CD-ROM drive
- At least one serial port - either RS232 or USB used with an RS232 to USB converter (available from Renishaw)

RCU10 kit identification

RCU10 compensation systems are available in a range of pre-defined kits to suit common system configurations from 1 to 6 axes. These kits are numbered using the following system:

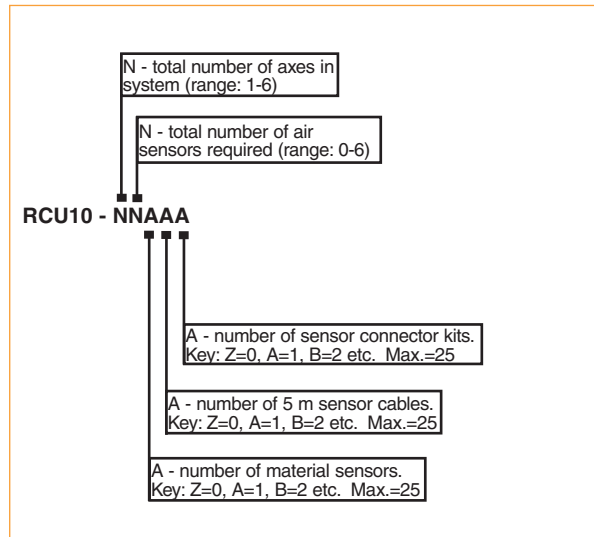

These pre-defined RCU10 compensation kits have 24 months warranty and include:

- RCU10 unit per axis*
- Material temperature sensor
- Pressure sensor (laser encoder kits only)
- Air temperature sensor per axis (laser encoder kits only)
- Sensor cables (1 off 5 m cable for sensor)
- Sensor connector kit
- RCU10 connector kit
- High speed serial link
- PC RS232 cable
- RCU10 CS software
- RCU10 installation manual

* It is assumed that if an air sensor is required, at least one axis will be using refractive index compensation, therefore one of the RCU10s provided will be an RCU10-PX-XX, which contains a pressure sensor.

Should you have an application requiring an RCU10 compensation system, please contact a Renishaw representative to discuss part numbering in detail.

The following accessories are also available:

- Serial-USB adapter (A-8014-0670)
- Sensor distribution box (RCU10-DB-XX)
- Armoured sensor cable (5 m) (RCU10-AC-X5)
- Sensor vacuum accessory kit (RCU10-VA-XX)
- Sensor vacuum connector assembly (A-9904-1711)
- Sensor vacuum seal kit (spare x 5) (A-9904-1712)

