



A Tech Authority, Inc  
3857 Schaefer Ave, Ste C  
Chino, CA. 91710  
(909)972-7520  
www.atechauthority.com

# HEIDENHAIN



**Linear Encoders**  
for Numerically Controlled  
Machine Tools

June 2007



Further information is available on the Internet at [www.heidenhain.de](http://www.heidenhain.de) as well as upon request.

Product brochures:

- Exposed Linear Encoders
- Angle Encoders with Integral Bearing
- Angle Encoders without Integral Bearing
- Rotary Encoders
- HEIDENHAIN subsequent electronics
- HEIDENHAIN controls
- Measuring Systems for Machine Tool Inspection and Acceptance Testing

Technical Information brochures:



- Accuracy of Feed Axes
- Sealed Linear Encoders with Single-Field Scanning
- EnDat 2.2 – Bidirectional Interface for Position Encoders
- Encoders for Direct Drives

*This catalog supersedes all previous editions, which thereby become invalid. The basis for ordering from HEIDENHAIN is always the catalog edition valid when the contract is made.*

*Standards (ISO, EN, etc.) apply only where explicitly stated in the catalog.*

DIADUR and AURODUR are registered trademarks of DR. JOHANNES HEIDENHAIN GmbH, Traunreut, Germany.

# Content

<b>Overview</b>			
		<b>Linear Encoders</b>	<b>4</b>
		<b>Selection Guide</b>	<b>6</b>
<b>Technical Features and Mounting Information</b>			
	<b>Measuring Principles</b>	Measuring Standard	<b>8</b>
		Absolute Measuring Method	<b>8</b>
		Incremental Measuring Method	<b>9</b>
		Photoelectric Scanning	<b>10</b>
	<b>Measuring Accuracy</b>		<b>12</b>
	<b>Mechanical Design Types and Mounting Guidelines</b>		<b>14</b>
	<b>General Mechanical Information</b>		<b>18</b>
<b>Specifications</b>	<i>Recommended measuring step for positioning</i>	<i>Series or Model</i>	
<i>Linear encoder</i>			
for absolute position measurement	to 0.1 $\mu\text{m}$	<b>LC 400 Series</b>	<b>20</b>
		<b>LC 100 Series</b>	<b>22</b>
for incremental linear measurement with very high repeatability	to 0.1 $\mu\text{m}$	<b>LF 481</b>	<b>24</b>
		<b>LF 183</b>	<b>26</b>
for incremental linear measurement	to 0.5 $\mu\text{m}$	<b>LS 400 Series</b>	<b>28</b>
		<b>LS 100 Series</b>	<b>30</b>
for incremental linear measurement for large measuring lengths	to 0.1 $\mu\text{m}$	<b>LB 382 – Single-Section</b>	<b>32</b>
		<b>LB 382 – Multi-Section</b>	<b>34</b>
<b>Electrical Connection</b>			
	<b>Incremental Signals</b>	 1 V <sub>PP</sub>	<b>36</b>
		 TTL	<b>38</b>
	<b>Absolute Position Values</b>	EnDat	<b>40</b>
		Fanuc and Mitsubishi	<b>47</b>
	<b>Connecting Elements and Cables</b>		<b>48</b>
	<b>General Electrical Information</b>		<b>52</b>
	<b>Evaluation Electronics</b>		<b>54</b>
	<b>HEIDENHAIN Measuring Equipment</b>		<b>55</b>

# Linear Encoders for Numerically Controlled Machine Tools

Linear encoders from HEIDENHAIN for numerically controlled machine tools can be used nearly everywhere. They are ideal for machines and other equipment whose feed axes are in a closed loop, such as milling machines, machining centers, boring machines, lathes and grinding machines. The beneficial dynamic behavior of the linear encoders, their highly reliable traversing speed, and their acceleration in the direction of measurement predestine them for use on highly-dynamic conventional axes as well as on direct drives.

HEIDENHAIN also supplies linear encoders for other applications, such as

- Manual machine tools
- Presses and bending machines
- Automation and production equipment

Please request further documentation, or inform yourself on the Internet at [www.heidenhain.de](http://www.heidenhain.de).

## Advantages of linear encoders

Linear encoders measure the position of linear axes without additional mechanical transfer elements. The control loop for position control with a linear encoder also includes the entire feed mechanics. Transfer errors from the mechanics can be detected by the linear encoder on the slide, and corrected by the control electronics. This can eliminate a number of potential error sources:

- Positioning error due to thermal behavior of the recirculating ball screw
- Hysteresis
- Kinematic error through ball-screw pitch error

Linear encoders are therefore indispensable for machines that must fulfill high requirements for **positioning accuracy** and **machining speed**.

## Mechanical design

The linear encoders for numerically controlled machine tools are sealed encoders: An aluminum housing protects the scale, scanning carriage and its guideway from chips, dust, and fluids. Downward-oriented elastic lips seal the housing.

The scanning carriage travels in a low-friction guide within the scale unit. A coupling connects the scanning carriage with the mounting block and compensates the misalignment between the scale and the machine guideways.

Depending on the encoder model, lateral and axial offsets of  $\pm 0.2$  to  $\pm 0.3$  mm between the scale and mounting block are permissible.



### Thermal behavior

The combination of increasingly rapid machining processes with completely enclosed machines leads to ever-increasing temperatures within the machine's work envelope. Therefore, the thermal behavior of the linear encoders used becomes increasingly important, since it is an essential criterion for the working accuracy of the machine.

As a general rule, the thermal behavior of the linear encoder should match that of the workpiece or measured object. During temperature changes, the linear encoder must expand or retract in a defined, reproducible manner. Linear encoders from HEIDENHAIN are designed for this.

The graduation carriers of HEIDENHAIN linear encoders have defined coefficients of thermal expansion (see *Specifications*). This makes it possible to select the linear encoder whose thermal behavior is best suited to the application.

### Dynamic behavior

The constant increases in efficiency and performance of machine tools necessitate ever-higher feed rates and accelerations, while at the same time the high level of machining accuracy must be maintained. In order to transfer rapid and yet exact feed motions, very high demands are placed on rigid machine design as well as on the linear encoders used.

Linear encoders from HEIDENHAIN are characterized by their high rigidity in the measuring direction. This is a very important prerequisite for high-quality path accuracies on a machine tool. In addition, the low mass of components moved contributes to their excellent dynamic behavior.

### Availability

The feed axes of machine tools travel quite large distances—a typical value is 10000 km in three years. Therefore, robust encoders with good long-term stability are especially important: They ensure the constant availability of the machine.

Due to the details of their design, linear encoders from HEIDENHAIN function properly even after years of operation. The contact-free principle of photoelectrically scanning the measuring standard, as well as the ball-bearing guidance of the scanning carriage in the scale housing ensure a long lifetime. This encapsulation, the special scanning principles and, if needed, the introduction of compressed air, make the linear encoders very resistant to contamination. The complete shielding concept ensures a high degree of electrical noise immunity.

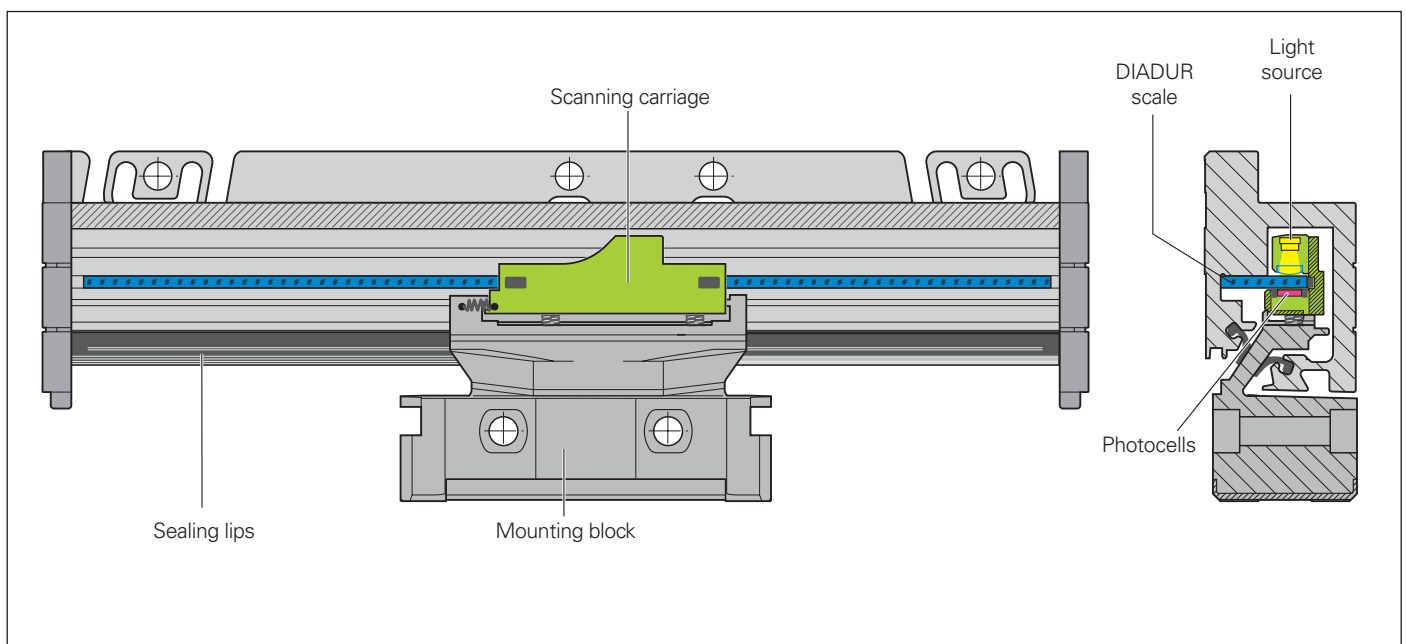

Schematic design of the **LC 183** sealed linear encoder

# Selection Guide

## Linear encoders with slimline scale housing

The linear encoders with **slimline scale housing** are designed for **limited installation space**. Larger measuring lengths and higher acceleration loads are made possible by using mounting spars or clamping elements.

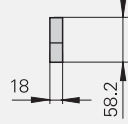
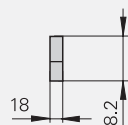
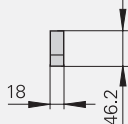
	Cross section	Measuring step <sup>1)</sup>	Accuracy grade	Measuring length
<b>Absolute linear measurement</b> <ul style="list-style-type: none"> <li>• Glass scale</li> </ul>		To 0.1 µm	± 5 µm ± 3 µm	70 mm to 1240 mm <i>With mounting spar or clamping elements: 70 mm to 2040 mm</i>
<b>Incremental linear measurement with very high repeatability</b> <ul style="list-style-type: none"> <li>• Steel scale</li> <li>• Small signal period</li> </ul>		To 0.1 µm	± 5 µm ± 3 µm	50 mm to 1220 mm
<b>Incremental linear measurement</b> <ul style="list-style-type: none"> <li>• Glass scale</li> </ul>		To 0.5 µm	± 5 µm ± 3 µm	70 mm to 1240 mm <i>With mounting spar: 70 mm to 2040 mm</i>

## Linear encoders with full-size scale housing

The linear encoders with **full-size scale housing** are characterized by their **sturdy construction, high resistance to vibration** and **large measuring lengths**. The scanning carriage is connected with the mounting block over an oblique blade that permits mounting both in **upright and reclining positions** with the same protection rating.

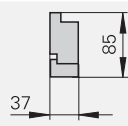
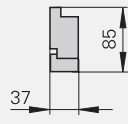
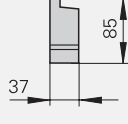
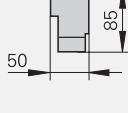
<b>Absolute linear measurement</b> <ul style="list-style-type: none"> <li>• Glass scale</li> </ul>		To 0.1 µm	± 5 µm ± 3 µm	140 mm to 4240 mm
<b>Incremental linear measurement with very high repeatability</b> <ul style="list-style-type: none"> <li>• Steel scale</li> <li>• Small signal period</li> </ul>		To 0.1 µm	± 3 µm ± 2 µm	140 mm to 3040 mm
<b>Incremental linear measurement</b> <ul style="list-style-type: none"> <li>• Glass scale</li> </ul>		To 0.5 µm	± 5 µm ± 3 µm	140 mm to 3040 mm
<b>Incremental linear measurement for large measuring lengths</b> <ul style="list-style-type: none"> <li>• Steel scale tape</li> </ul>		To 0.1 µm	± 5 µm	440 mm to 30040 mm

<sup>1)</sup> Recommended measuring step for position measurement

Scanning principle	Incremental signals Signal period	Absolute position values	Model	Page
Single-field scanning	$\sim 1 V_{PP}; 20 \mu m$	EnDat 2.2	<b>LC 483</b>	<b>20</b>
	–	Fanuc 02	<b>LC 493F</b>	
	–	Mit 02-4 Mitsu 01	<b>LC 493M</b>	
Single-field scanning	$\sim 1 V_{PP}; 4 \mu m$	–	<b>LF 481</b>	<b>24</b>
Single-field scanning	$\sim 1 V_{PP}; 20 \mu m$	–	<b>LS 487</b>	<b>28</b>
	$\square$ TTL; to $1 \mu m$	–	<b>LS 477</b>	
Single-field scanning	$\sim 1 V_{PP}; 20 \mu m$	EnDat 2.2	<b>LC 183</b>	<b>22</b>
	–	Fanuc 02	<b>LC 193F</b>	
	–	Mit 02-4 Mitsu 01	<b>LC 193M</b>	
Single-field scanning	$\sim 1 V_{PP}; 4 \mu m$	–	<b>LF 183</b>	<b>26</b>
Single-field scanning	$\sim 1 V_{PP}; 20 \mu m$	–	<b>LS 187</b>	<b>30</b>
	$\square$ TTL; To $1 \mu m$	–	<b>LS 177</b>	
Single-field scanning	$\sim 1 V_{PP}; 40 \mu m$		<b>LB 382</b>	<b>32</b>



**LC 483**



**LS 487**



**LC 183**



**LF 183**



**LB 382**

# Measuring Principles

## Measuring Standard

HEIDENHAIN encoders with optical scanning incorporate measuring standards of periodic structures known as graduations.

These graduations are applied to a carrier substrate of glass or steel. The scale substrate for large measuring lengths is a steel tape.

These precision graduations are manufactured in various photolithographic processes. Graduations can be fabricated from:

- extremely hard chromium lines on glass,
- matte-etched lines on gold-plated steel tape, or
- three-dimensional grid structures on glass or steel substrates.

The photolithographic manufacturing processes developed by HEIDENHAIN produce grating periods of typically 40  $\mu\text{m}$  to 4  $\mu\text{m}$ .

Along with these very fine grating periods, these processes permit a high definition and homogeneity of the line edges. Together with the photoelectric scanning method, this high edge definition is a precondition for the high quality of the output signals.

The master graduations are manufactured by HEIDENHAIN on custom-built high-precision ruling machines.

## Absolute Measuring Method

With the **absolute measuring method**, the position value is available from the encoder immediately upon switch-on and can be called at any time by the subsequent electronics. There is no need to move the axes to find the reference position. The absolute position information is read **from the scale graduation**, which is formed from a serial absolute code structure. A separate incremental track is interpolated for the position value and at the same time is used to generate an optional incremental signal.

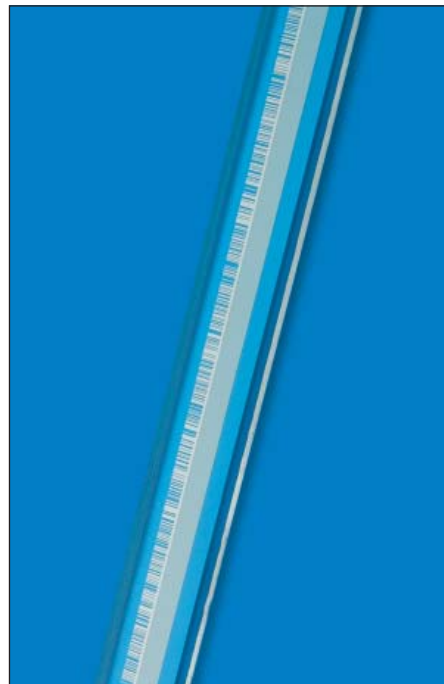

Graduation of an absolute linear encoder

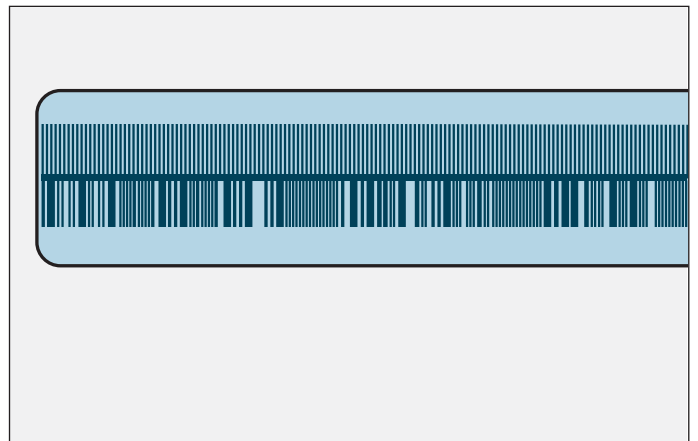

Schematic representation of an absolute code structure with an additional incremental track (LC 483 as example)



# Incremental Measuring Method

With the **incremental measuring method**, the graduation consists of a periodic grating structure. The position information is obtained **by counting** the individual increments (measuring steps) from some point of origin. Since an absolute reference is required to ascertain positions, the scales or scale tapes are provided with an additional track that bears a **reference mark**. The absolute position on the scale, established by the reference mark, is gated with exactly one signal period. The reference mark must therefore be scanned to establish an absolute reference or to find the last selected datum.

In some cases this may necessitate machine movement over large lengths of the measuring range. To speed and simplify such "reference runs," many encoders feature **distance-coded reference marks**—multiple reference marks that are individually spaced according to a mathematical algorithm. The subsequent electronics find the absolute reference after traversing two successive reference marks—only a few millimeters traverse (see table).

Encoders with distance-coded reference marks are identified with a "C" behind the model designation (e.g. LS 487C).

With distance-coded reference marks, the **absolute reference** is calculated by counting the signal periods between two reference marks and using the following formula:

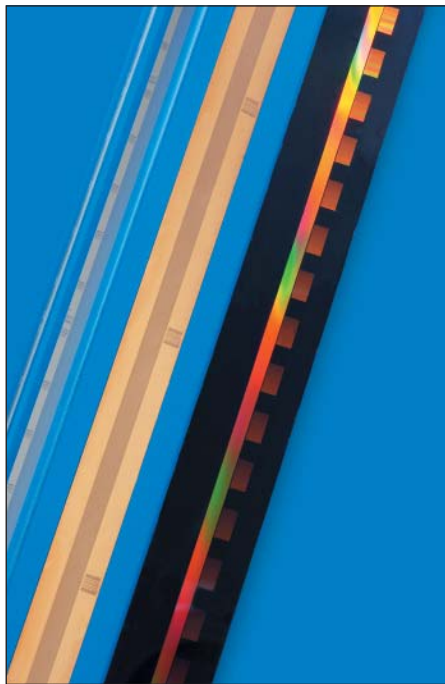

Graduations of incremental linear encoders

$$P_1 = (\text{abs } B - \text{sgn } B - 1) \times \frac{N}{2} + (\text{sgn } B - \text{sgn } D) \times \frac{\text{abs } M_{RR}}{2}$$

where:

$$B = 2 \times M_{RR} - N$$

and:

$P_1$  = Position of the first traversed reference mark in signal periods

abs = Absolute value

sgn = Sign function (" +1 " or " -1 ")

$M_{RR}$  = Number of signal periods between the traversed reference marks

$N$  = Nominal increment between two fixed reference marks in signal periods (see table below)

$D$  = Direction of traverse (+1 or -1). Traverse of scanning unit to the right (when properly installed) equals +1.

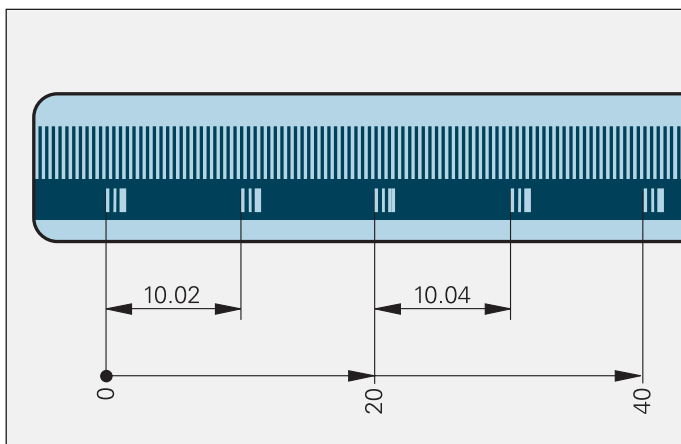

Schematic representation of an incremental graduation with distance-coded reference marks (LS as example)

	Signal period	Nominal increment $N$ in signal periods	Maximum traverse
LF	4 $\mu\text{m}$	5 000	20 mm
LS	20 $\mu\text{m}$	1 000	20 mm
LB	40 $\mu\text{m}$	2 000	80 mm

# Photoelectric Scanning

Most HEIDENHAIN encoders operate using the principle of photoelectric scanning. The photoelectric scanning of a measuring standard is contact-free, and therefore without wear. This method detects even very fine lines, no more than a few microns wide, and generates output signals with very small signal periods.

The finer the grating period of a measuring standard is, the greater the effect of diffraction on photoelectric scanning. HEIDENHAIN uses two scanning principles with linear encoders:

- The **imaging scanning principle** for grating periods from 20  $\mu\text{m}$  and 40  $\mu\text{m}$
- The **interferential scanning principle** for very fine graduations with grating periods of 8  $\mu\text{m}$  and smaller.

## Imaging scanning principle

To put it simply, the imaging scanning principle functions by means of projected-light signal generation: two scale gratings with equal or similar grating periods are moved relative to each other—the scale and the scanning reticle. The carrier material of the scanning reticle is transparent, whereas the graduation on the measuring standard may be applied to a transparent or reflective surface.

When parallel light passes through a grating, light and dark surfaces are projected at a certain distance, where there is an index grating. When the two gratings move relative to each other, the incident light is modulated. If the gaps in the gratings are aligned, light passes through. If the lines of one grating coincide with the gaps of the other, no light passes through. An array of photovoltaic cells converts these variations in light intensity into electrical signals. The specially structured grating of the scanning reticle filters the light current to generate nearly sinusoidal output signals.

The smaller the period of the grating structure is, the closer and more tightly tolerated the gap must be between the scanning reticle and scale.

The LC, LS and LB linear encoders operate according to the imaging scanning principle.

Imaging scanning principle

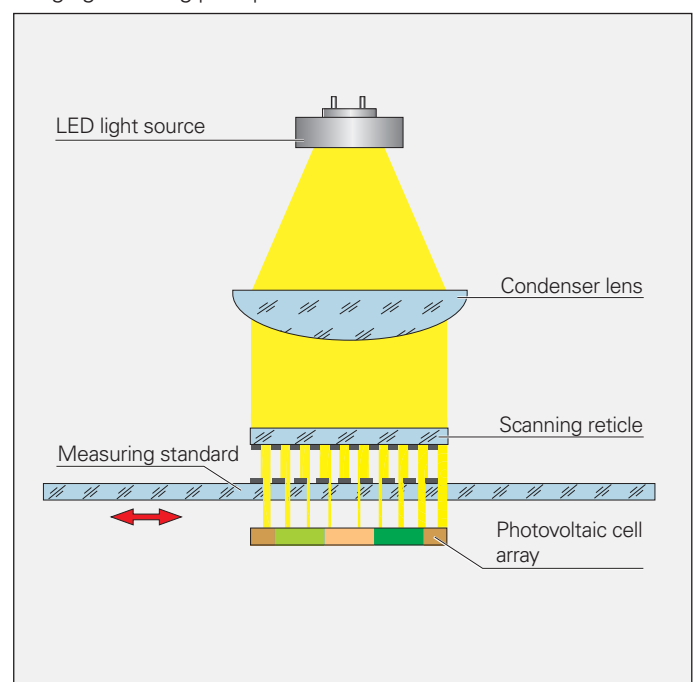

**Interferential scanning principle**

The interferential scanning principle exploits the diffraction and interference of light on a fine graduation to produce signals used to measure displacement.

A step grating is used as the measuring standard: reflective lines 0.2 μm high are applied to a flat, reflective surface. In front of that is the scanning reticle—a transparent phase grating with the same grating period as the scale.

When a light wave passes through the scanning reticle, it is diffracted into three partial waves of the orders -1, 0, and +1, with approximately equal luminous intensity. The waves are diffracted by the scale such that most of the luminous intensity is found in the reflected diffraction orders +1 and -1. These partial waves meet again at the phase grating of the scanning reticle where they are diffracted again and interfere. This produces essentially three waves that leave the scanning reticle at different angles. Photovoltaic cells convert this alternating light intensity into electrical signals.

A relative motion of the scanning reticle to the scale causes the diffracted wave fronts to undergo a phase shift: when the grating moves by one period, the wave front of the first order is displaced by one wavelength in the positive direction, and the wavelength of diffraction order -1 is displaced by one wavelength in the negative direction. Since the two waves interfere with each other when exiting the grating, the waves are shifted relative to each other by two wavelengths. This results in two signal periods from the relative motion of just one grating period.

Interferential encoders function with grating periods of, for example, 8 μm, 4 μm and finer. Their scanning signals are largely free of harmonics and can be highly interpolated. These encoders are therefore especially suited for high resolution and high accuracy.

Sealed linear encoders that operate according to the interferential scanning principle are given the designation LF.

Interferential scanning principle (optics schematics)

C Grating period

ψ Phase shift of the light wave when passing through the scanning reticle

Ω Phase shift of the light wave due to motion X of the scale

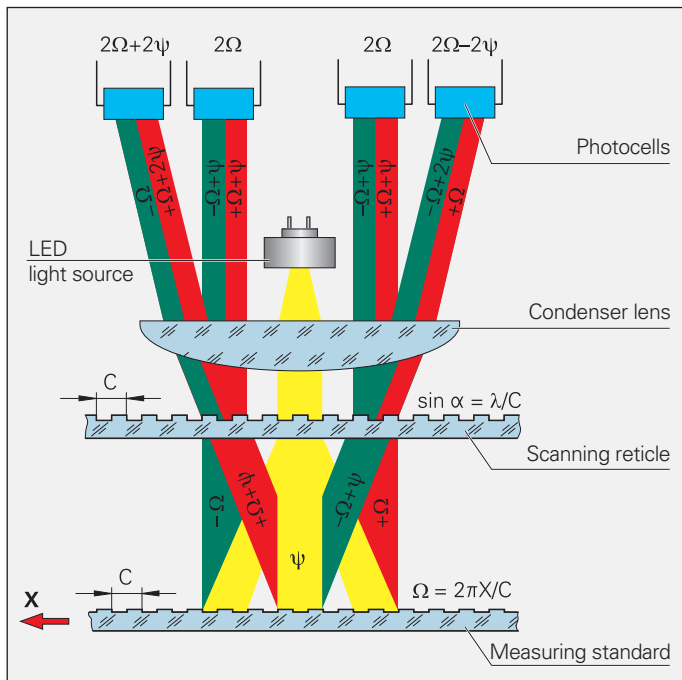

# Measuring Accuracy

The accuracy of linear measurement is mainly determined by:

- The quality of the graduation
- The quality of the scanning process
- The quality of the signal processing electronics
- The error from the scanning unit guideway to the scale

A distinction is made between position errors over relatively large paths of traverse—for example the entire measuring length—and those within one signal period.

## Position error over the measuring range

The accuracy of sealed linear encoders is specified in grades, which are defined as follows:

*The extreme values  $\pm F$  of the measuring curves over any max. one-meter section of the measuring length lie within the accuracy grade  $\pm a$ . They are ascertained during the final inspection, and are indicated on the calibration chart.*

With sealed linear encoders, these values apply to the complete encoder system including the scanning unit. It is then referred to as the system accuracy.

## Position error within one signal period

The position error within one signal period is determined by the signal period of the encoder, as well as the quality of the graduation and the scanning thereof. At any measuring position, it does not exceed  $\pm 2\%$  of the signal period, and for the LC and LS linear encoders it is typically  $\pm 1\%$ . The smaller the signal period, the smaller the position error within one signal period.

	Signal period of scanning signals	Max. position error $u$ within one signal period
LF	4 $\mu\text{m}$	Approx. 0.08 $\mu\text{m}$
LC	20 $\mu\text{m}$	Approx. 0.2 $\mu\text{m}$
LS	20 $\mu\text{m}$	Approx. 0.2 $\mu\text{m}$
LB	40 $\mu\text{m}$	Approx. 0.8 $\mu\text{m}$

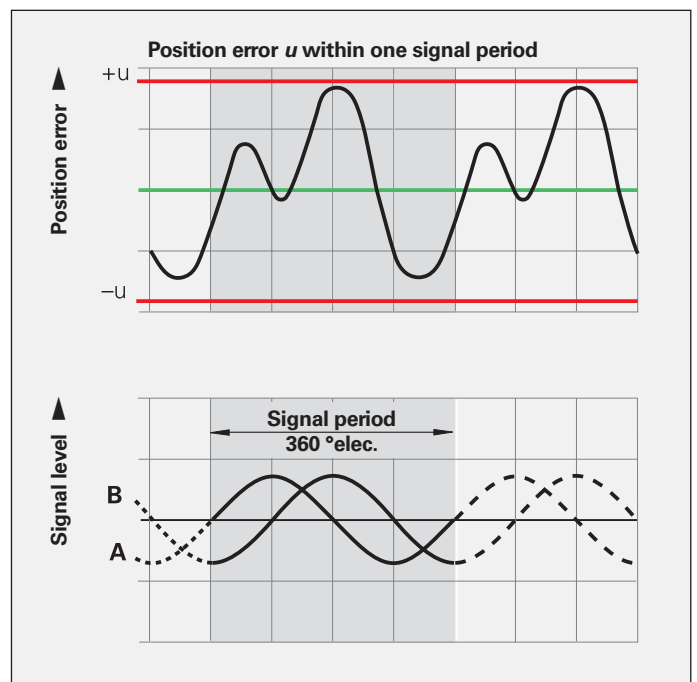
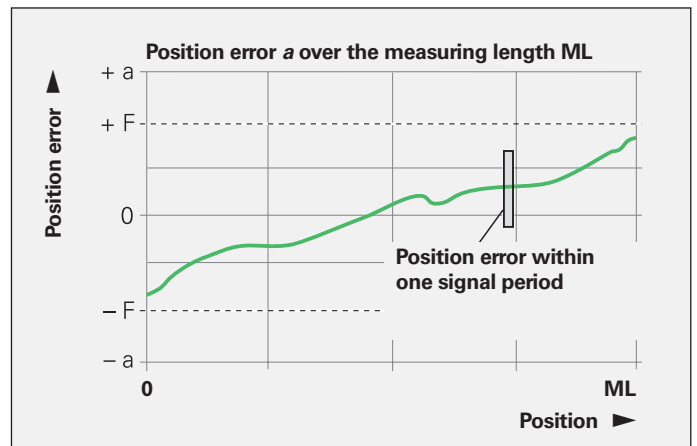

All HEIDENHAIN linear encoders are inspected before shipping for positioning accuracy and proper function.

The position errors are measured by traversing in both directions, and the averaged curve is shown in the calibration chart.

The **Quality Inspection Certificate** confirms the specified system accuracy of each encoder. The **calibration standards** ensure the traceability—as required by ISO 9001—to recognized national or international standards.

For the LC, LF and LS series listed in this brochure, a calibration chart documents the additional **position error** over the measuring length. The measurement parameters and uncertainty of the measuring machine are also stated.

**Temperature range**

The linear encoders are inspected at a **reference temperature** of 20 °C. The system accuracy given in the calibration chart applies at this temperature.

The **operating temperature range** indicates the ambient temperature limits between which the linear encoders will function properly. The **storage temperature range** of -20 °C to 70 °C applies for the unit in its packaging.



# HEIDENHAIN

**Qualitätsprüf-Zertifikat**  
DIN 55 350-18-4.2.2

**Quality Inspection Certificate**  
DIN 55 350-18-4.2.2

**LC 483**  
**ID 557649-09**  
**SN 19765168**

**Positionsabweichung F [µm]**  
Position error F [µm]

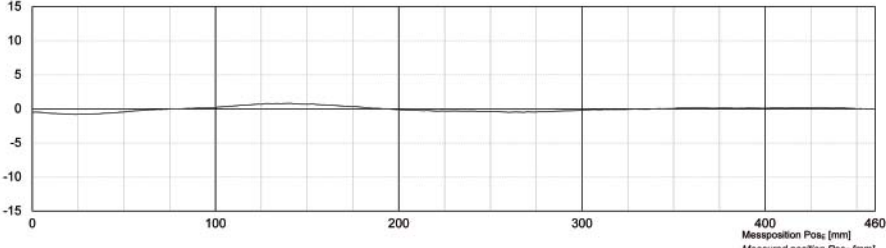

**Messposition Pos<sub>M</sub> [mm]**  
Measured position Pos<sub>M</sub> [mm]

Die Messkurve zeigt die Mittelwerte der Positionsabweichungen aus Vorwärts- und Rückwärtsmessung.

Positionsabweichung F des Längenmessgerätes: F = Pos<sub>M</sub> - Pos<sub>E</sub>  
Pos<sub>M</sub> = Messposition der Messmaschine  
Pos<sub>E</sub> = Messposition des Längenmessgerätes

<b>Maximale Positionsabweichung der Messkurve</b>	
innerhalb 460 mm	± 0,81 µm

The error curve shows the mean values of the position errors from measurements in forward and backward direction.

Position error F of the linear encoder: F = Pos<sub>M</sub> - Pos<sub>E</sub>  
Pos<sub>M</sub> = position measured by the measuring machine  
Pos<sub>E</sub> = position measured by the linear encoder

<b>Maximum position error of the error curve</b>	
within 460 mm	± 0,81 µm

Unsicherheit der Messmaschine

<small>U<sub>rel</sub> = 0,2 µm + 0,6 · 10<sup>-4</sup> · L (L=Länge Messintervall)</small>	
---------------------------------------------------------------------------------------------	--

Uncertainty of the measuring machine

<small>U<sub>rel</sub> = 0,2 µm + 0,6 · 10<sup>-4</sup> · L (L=measurement interval length)</small>	
-----------------------------------------------------------------------------------------------------	--

Messparameter

<small>Messschritt</small>	<small>1000 µm</small>
<small>Relative Luftfeuchtigkeit</small>	<small>max. 50%</small>

Measurement parameters

<small>Measurement step</small>	<small>1000 µm</small>
<small>Relative humidity</small>	<small>max. 50%</small>

Dieses Längenmessgerät wurde unter strengen HEIDENHAIN-Qualitätsnormen hergestellt und geprüft. Die Positionsabweichung liegt bei einer Bezugs temperatur von 20 °C innerhalb der Genauigkeitsklasse ± 5,0 µm.

Kalibriernormale	Kalibriertzeichen
<small>Jod-stabilisierter He-Ne Laser</small>	<small>3659 PTB 02</small>
<small>Wasser-Tripelpunktzelle</small>	<small>66 PTB 05</small>
<small>Gallium-Schmelzpunktzelle</small>	<small>67 PTB 05</small>
<small>Barometer</small>	<small>4945 DKD-K-02301 05-09</small>
<small>Luftfeuchtemessgerät</small>	<small>01758 DKD-K-00305 05-05</small>

This linear encoder has been manufactured and inspected in accordance with the stringent quality standards of HEIDENHAIN. The position error at a reference temperature of 20 °C lies within the accuracy grade ± 5.0 µm.

Calibration standards	Calibration reference
<small>Iodine-stabilized He-Ne Laser</small>	<small>3659 PTB 02</small>
<small>Water triple point cell</small>	<small>66 PTB 05</small>
<small>Gallium melting point cell</small>	<small>67 PTB 05</small>
<small>Pressure gauge</small>	<small>4945 DKD-K-02301 05-09</small>
<small>Hydrometer</small>	<small>01758 DKD-K-00305 05-05</small>

DR. JOHANNES HEIDENHAIN GmbH · 83301 Traunreut · www.heidenhain.de · Telefon: +49 (8669) 31-0 · Fax: +49 (8669) 5081

14.02.2007 *Krajcar Michael*  
Prüfer/Inspected by **M. Krajcar**

Example

# Mechanical Design Types and Mounting Guidelines

## Linear Encoders with Small Cross Section

The LC, LF and LS slimline linear encoders should be fastened to a machined surface over their entire length, especially for highly-dynamic requirements. Larger measuring lengths and higher vibration loads are made possible by using mounting spars or clamping elements (only for LC 4x3).

The encoder is mounted so that the sealing lips are directed downward or away from splashing water (also see *General Mechanical Information*).

### Thermal behavior

Because they are rigidly fastened using two M8 screws, the linear encoders largely adapt themselves to the mounting surface. When fastened over the mounting spar, the encoder is fixed at its midpoint of the mounting surface. The flexible fastening elements ensure reproducible thermal behavior.

The **LF 481** with its graduation carrier of steel has the same coefficient of thermal expansion as a mounting surface of gray cast iron or steel.

### Mounting

It is surprisingly simple to mount the sealed linear encoders from HEIDENHAIN: You need only align the scale unit at several points along the machine guideway. Stop surfaces or stop pins can also be used for this. The shipping brace already sets the proper gap between the scale unit and the scanning unit, as well as the lateral tolerance. If the shipping brace needs to be removed before mounting due to a lack of space, then the mounting gauge is used to set the gap between the scale unit and the scanning unit easily and exactly. You must also ensure that the lateral tolerances are maintained.

*Accessories:*

### Mounting and test gauges for slimline linear encoders

The **mounting gauge** is used to set the gap between the scale unit and the scanning unit if the shipping brace needs to be removed before mounting. The **test gauges** are used to quickly and easily check the gap of the mounted linear encoder.

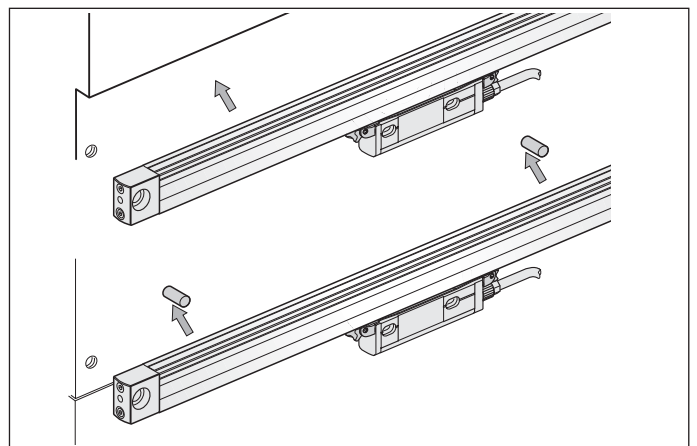
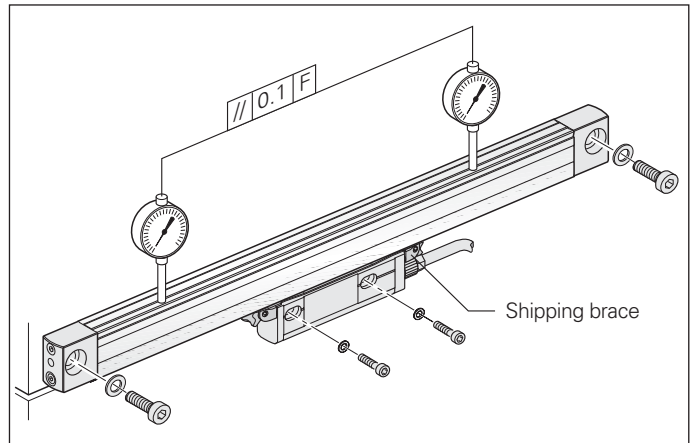
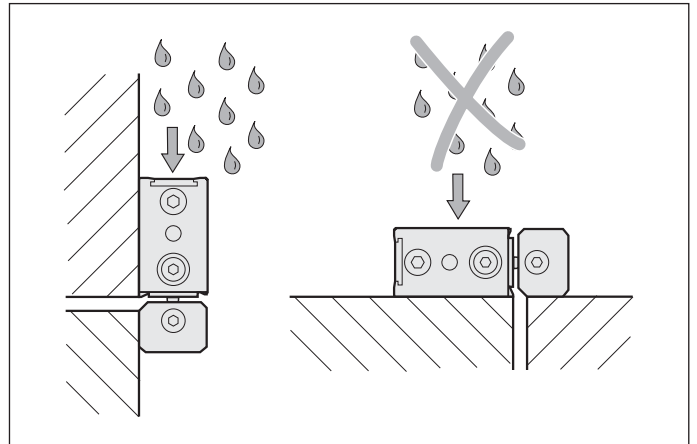

	x	Color	ID
<b>Mounting gauge</b>	1.0 mm	Gray	528 753-01
<b>Max. test gauge</b>	1.3 mm	Red	528 753-02
<b>Min. test gauge</b>	0.7 mm	Blue	528 753-03

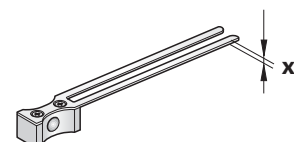



Along with the standard procedure of using two M8 screws to mount the scale unit on a plane surface, there are also other mounting possibilities:

#### Installation with mounting spar

The use of a mounting spar can be of great benefit when mounting slimline linear encoders. They can be fastened as part of the machine assembly process. The encoder is then simply clamped on during final mounting. Easy exchange also facilitates servicing.

A mounting spar is recommended for highly-dynamic applications with ML greater than 640 mm. It is always necessary for measuring lengths starting from 1240 mm.

The **universal mounting spar** was developed specifically for the LC 4x3 and LS 4x7. It can be mounted very easily, since the components necessary for clamping are premounted. Linear encoders with normal head mounting blocks and—if compatibility considerations require them—linear encoders with short end blocks can be mounted. Other advantages:

- **Mechanically compatible versions**

The universal mounting spar and the LC 4x3 and the LS 4x7 are compatible in their mating dimensions to the previous versions. Any combinations are possible, such as the LS 4x6 with the universal mounting spar, or the LC 4x3 with the previous mounting spar.

- **Freely selectable cable outlet**

The LC 4x3 and the LS 4x7 can be mounted with either side facing the universal mounting spar. This permits the cable exit to be located on the left or right—a very important feature if installation space is limited.

The universal mounting spar must be ordered separately, even for measuring lengths over 1240 mm.

Accessory:

#### Universal mounting spar

ID 571 613-xx

#### Mounting with clamping elements

The scale unit of the LC 4x3 is fastened at both ends. In addition, it can also be attached to the mounting surface by clamping elements. This way the fastening at the center of the measuring length (recommended for highly-dynamic applications with ML greater than 620 mm) is easy and reliable. This makes mounting without the mounting spar possible for measuring lengths greater than 1240 mm.

Accessory:

#### Clamping elements

With pin and M5x10 screw

ID 556975-01 (10 units per package)

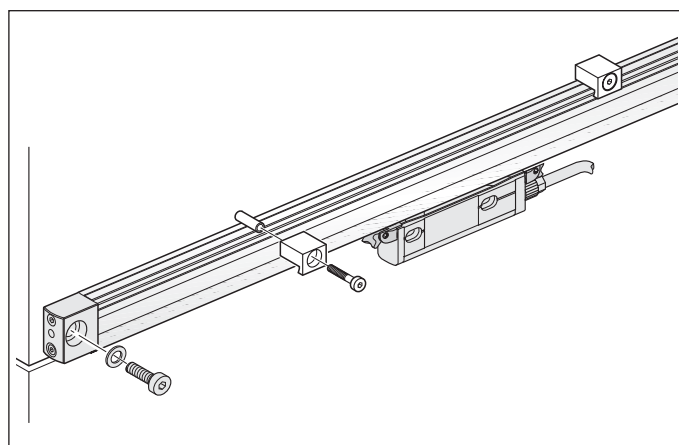
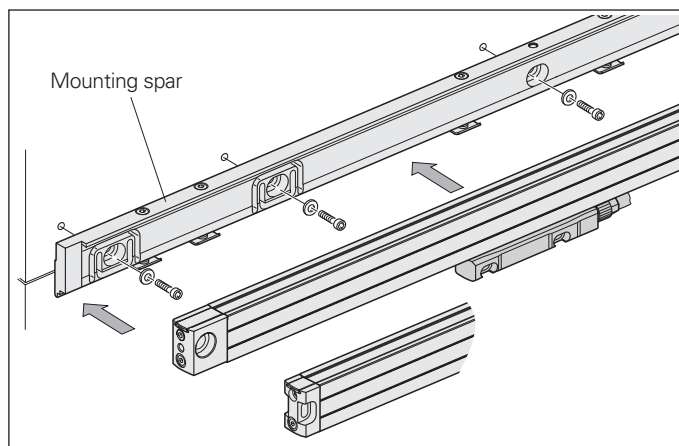

# Linear Encoders with Large Cross Section

The LB, LC, LF and LS full-size linear encoders are fastened over their entire length onto a machined surface. This gives them a **high vibration rating**. The inclined arrangement of the sealing lips permits **universal mounting** with vertical or horizontal scale housing with equally high protection rating.

## Thermal behavior

The thermal behavior of the LB, LC, LF and LS 100 linear encoders with large cross section has been optimized:

On the **LF** the steel scale is cemented to a steel carrier that is fastened directly to the machine element.

On the **LB** the steel scale tape is clamped directly onto the machine element. The LB therefore takes part in all thermal changes of the mounting surface.

**LC** and **LS** are fixed to the mounting surface at their midpoint. The flexible fastening elements permit reproducible thermal behavior.

## Mounting

It is surprisingly simple to mount the sealed linear encoders from HEIDENHAIN: You need only align the scale unit at several points along the machine guideway. Stop surfaces or stop pins can also be used for this. The shipping brace already sets the proper gap between the scale unit and the scanning unit. The lateral gap is to be set during mounting. If the shipping brace needs to be removed before mounting due to a lack of space, then the mounting gauge is used to set the gap between the scale unit and the scanning unit easily and exactly. You must also ensure that the lateral tolerances are maintained.

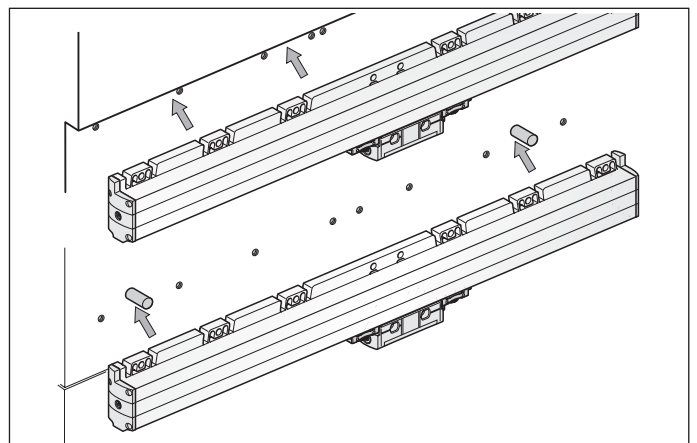
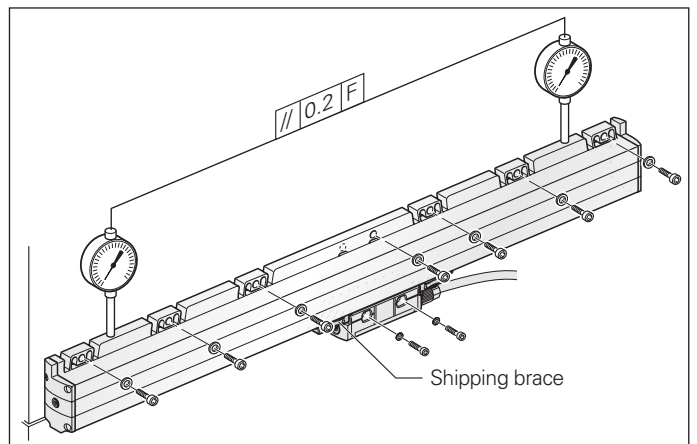
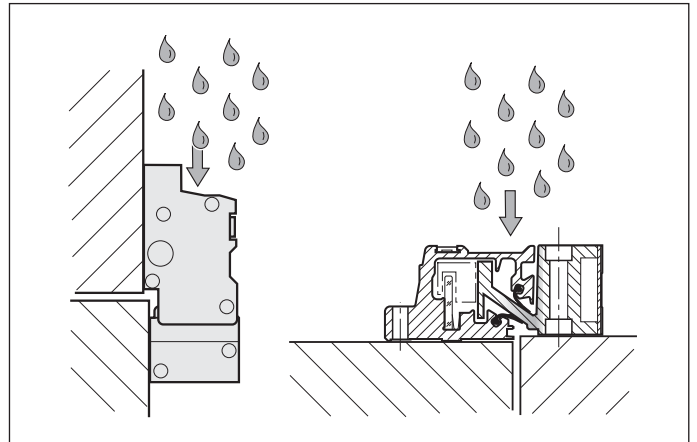



### Mounting the multi-section LB 382

The LB 382 with measuring lengths over 3240 mm is mounted on the machine in individual sections:

- Mount and align the individual housing sections
- Pull in the scale tape over the entire length and tension it
- Pull in the sealing lips
- Insert the scanning unit

Adjustment of the tensioning of the scale tape enables linear machine error compensation up to  $\pm 100 \mu\text{m}/\text{m}$ .

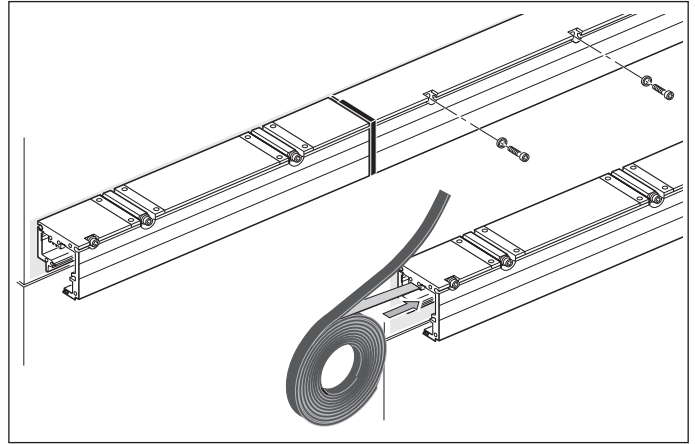

Accessory:

### Mounting aid for LC 1x3 and LS 1x7 ID 547793-01

The mounting aid is locked onto the scale unit, simulating an optimally adjusted scanning unit. The customer's mating surface for the scanning unit can then be aligned to it. The mounting aid is then removed and the scanning unit is attached to the mounting bracket.

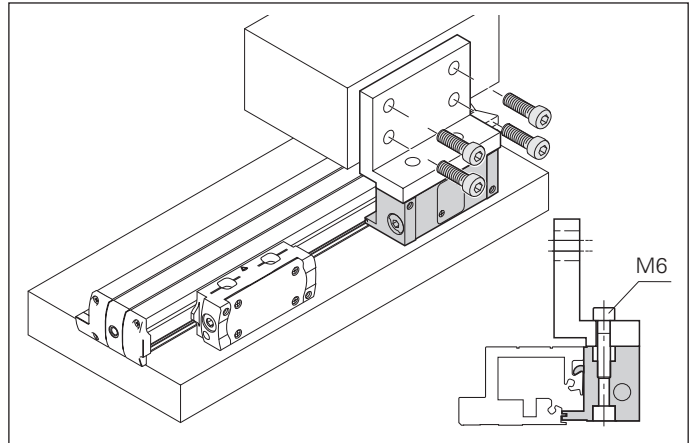

Example

	x	Color	ID
<b>Mounting gauge</b>	1.5 mm	Gray	575832-01
<b>Max. test gauge</b>	1.8 mm	Red	575832-02
<b>Min. test gauge</b>	1.2 mm	Blue	575832-03

Accessories:

### Mounting and test gauges for full-size linear encoders

The **mounting gauge** is used to set the gap between the scale unit and the scanning unit if the shipping brace needs to be removed before mounting. The **test gauges** are used to quickly and easily check the gap of the mounted linear encoder.

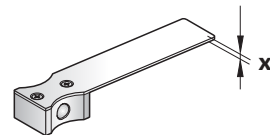

# General Mechanical Information

## Protection

Sealed **linear encoders** fulfill the requirements for IP 53 protection according to **IEC 60529** provided that they are mounted with the sealing lips facing away from splash water. If necessary, provide a separate protective cover. If the encoder is exposed to particularly heavy concentrations of coolant and mist, **compressed air** can be conducted into the scale housing to provide **IP 64** protection to more effectively prevent the ingress of contamination. The LB, LC, LF and LS sealed linear encoders from HEIDENHAIN are therefore equipped with inlets at both end pieces and on the mounting block of the scanning unit.

The compressed air introduced directly onto the encoders must be appropriately conditioned, and must comply with the following quality classes as per **ISO 8573-1** (1995 edition):

- Solid contaminants: Class 1 (max. particle size 0.1  $\mu\text{m}$  and max. particle density 0.1  $\text{mg}/\text{m}^3$  at  $1 \cdot 10^5$  Pa)
- Total oil content: Class 1 (max. oil concentration 0.01  $\text{mg}/\text{m}^3$  at  $1 \cdot 10^5$  Pa)
- Max. pressure dew point: Class 4, but with reference conditions of  $+3^\circ\text{C}$  at  $2 \cdot 10^5$  Pa

The required air flow is 7 to 10 l/min per linear encoder; permissible pressure is in the range of 0.6 to 1 bar). The compressed air flows through connecting pieces with integrated throttle (included with LB and LF linear encoders).

### Accessories:

**Connecting piece, straight** with throttle and gasket  
ID 226270-xx

**Connecting piece, straight, short** with throttle and gasket  
ID 275239-xx

**M5 coupling joint, swiveling** with seal  
ID 207834-xx

### Accessory:

**DA 300 compressed air unit**  
ID 348249-01

HEIDENHAIN offers the **DA 300 compressed air unit** for purifying and conditioning compressed air. It consists of two filter stages (fine filter and activated carbon filter), automatic condensation trap, and a pressure regulator with pressure gauge. It also includes 25 meters of pressure tubing, as well as T-joints and connecting pieces for four encoders. The DA 300 can supply air for up to 10 encoders with a maximum total measuring length of 35 meters.

The compressed air introduced into the DA 300 must fulfill the requirements of the following quality classes as per ISO 8573-1 (1995 edition):

- Max. particle size and density of solid contaminants:  
Class 4 (max. particle size 15  $\mu\text{m}$ , max. particle density 8  $\text{mg}/\text{m}^3$ )
- Total oil content:  
Class 4 (oil content: 5  $\text{mg}/\text{m}^3$ )
- Max. pressure dew point:  
Not defined  
Class 7

For more information, ask for our *DA 300* product information sheet.

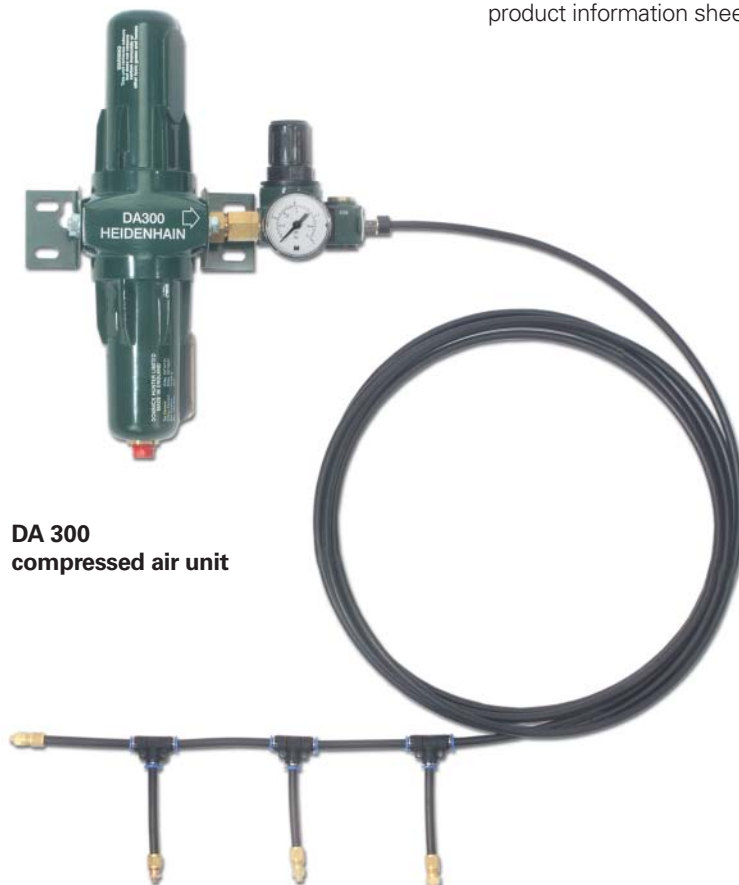

**DA 300**  
compressed air unit

## Mounting

To simplify cable routing, the mounting block of the scanning unit is usually screwed onto a stationary machine part.

The **mounting location** for the linear encoders should be carefully considered in order to ensure both optimum accuracy and the longest possible service life.

- The encoder should be mounted as closely as possible to the working plane to keep the Abbé error small.
- To function properly, linear encoders must not be continuously subjected to strong vibration. The more solid parts of the machine tool provide the best mounting surface in this respect. Encoders should not be mounted on hollow parts or with adapters. A mounting spar is recommended for the sealed linear encoders with small cross section.
- The linear encoders should be mounted away from sources of heat to avoid temperature influences.

## Acceleration

Linear encoders are subjected to various types of acceleration during operation and mounting.

- The indicated maximum values for **vibration** apply for frequencies of 55 to 2000 Hz (**IEC 60068-2-6**). Any acceleration exceeding permissible values, for example due to resonance depending on the application and mounting, might damage the encoder. **Comprehensive tests of the entire system are required.**
- The maximum permissible acceleration values (semi-sinusoidal shock) for **shock and impact** are valid for 11 ms (**IEC 60068-2-27**). Under no circumstances should a hammer or similar implement be used to adjust or position the encoder.

## Required moving force

The required moving force stated is the maximum force required to move the scale unit relative to the scanning unit.

## Expendable parts

HEIDENHAIN encoders contain components that are subject to wear, depending on the application and manipulation. These include in particular the following parts:

- LED light source
  - Cables with frequent flexing
- Additionally for encoders with integral bearing:
- Bearing
  - Shaft sealing rings for rotary and angular encoders
  - Sealing lips for sealed linear encoders

## System tests

Encoders from HEIDENHAIN are usually integrated as components in larger systems. Such applications require **comprehensive tests of the entire system** regardless of the specifications of the encoder.

The specifications given in the brochure apply to the specific encoder, not to the complete system. Any operation of the encoder outside of the specified range or for any other than the intended applications is at the user's own risk.

In safety-oriented systems, the higher-level system must verify the position value of the encoder after switch-on.

## Mounting

Work steps to be performed and dimensions to be maintained during mounting are specified solely in the mounting instructions supplied with the unit. All data in this catalog regarding mounting are therefore provisional and not binding; they do not become terms of a contract.

# LC 400 Series

- Absolute linear encoders for measuring steps to 0.1 µm (resolution to 0.005 µm)
- For limited installation space
- Up to two additional scanning units are possible

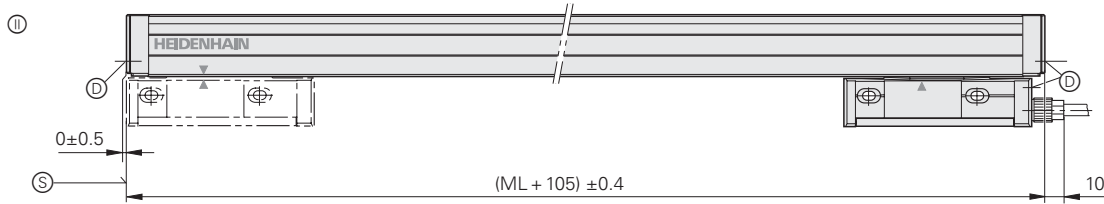
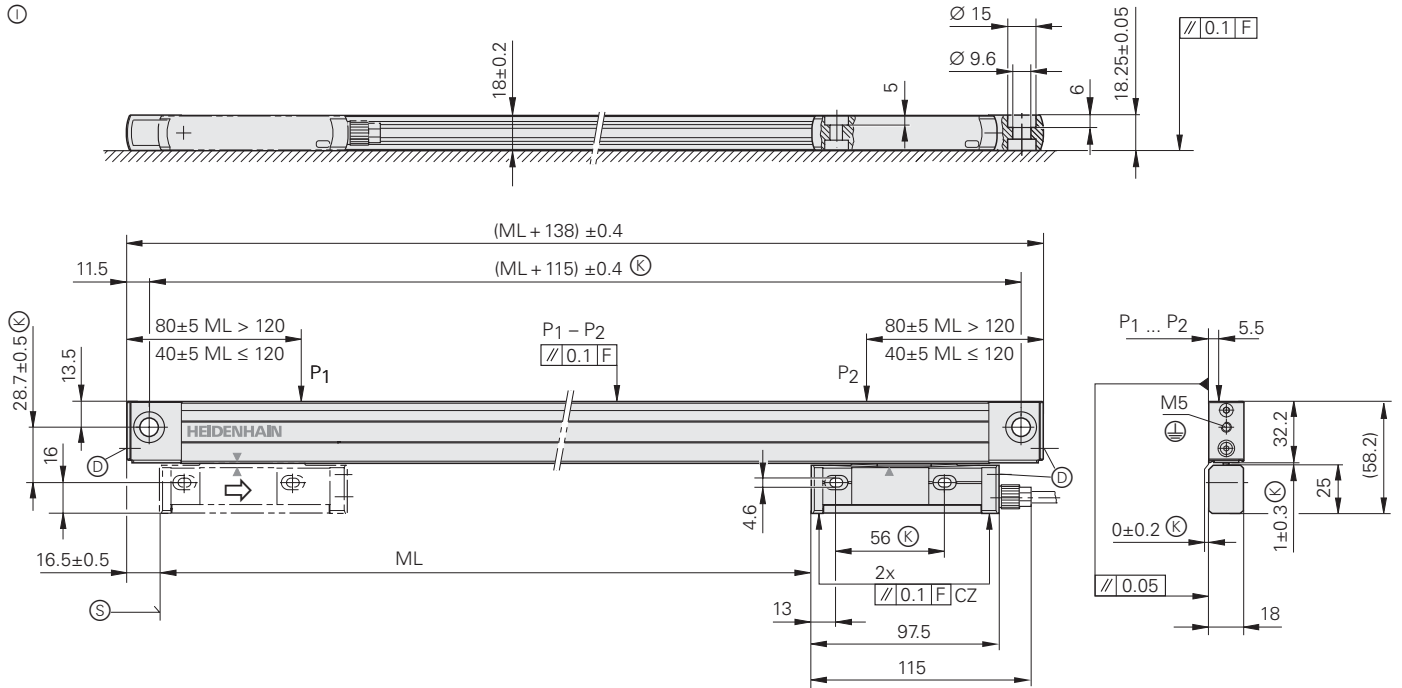

For mounting options see  
Mounting Instructions  
([www.heidenhain.de](http://www.heidenhain.de))

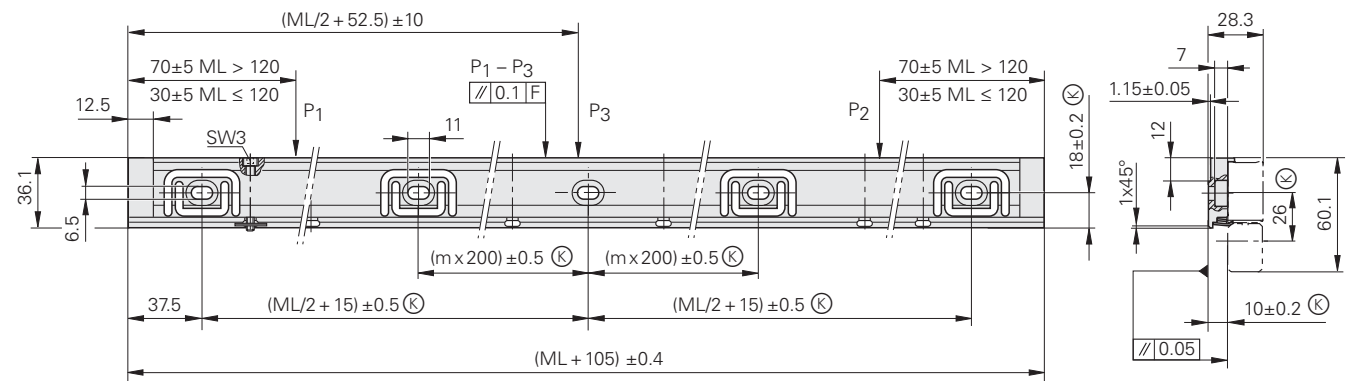

Dimensions in mm



Tolerancing ISO 8015  
ISO 2768 - m H  
< 6 mm:  $\pm 0.2$  mm

- $\textcircled{1}$  = Without mounting spar (with M8 screws)
- $\textcircled{2}$  = Mounting with mounting spar (LC 483 with short end pieces shown; LC with normal end pieces can also be mounted)
- F = Machine guideway
- P = Gauging points for alignment  
ML  $\leq$  820  $P_1 - P_2$   
ML  $>$  820  $P_1 - P_3$
- $\textcircled{C}$  = Required mating dimensions
- $\textcircled{A}$  = Compressed air inlet
- $\textcircled{S}$  = Beginning of measuring length (ML) (at 20 mm)
- $\Rightarrow$  = Direction of scanning unit motion for output signals in accordance with interface description

### Mounting spar

ML	m
70 ... 520	0
570 ... 920	1
1020 ... 1340	2
1440 ... 1740	3
1840 ... 2040	4



LC 483 without mounting spar

LC 483 with mounting spar

Specifications	LC 483	LC 493 F	LC 493 M
<b>Measuring standard</b> Expansion coefficient	DIADUR glass scale with absolute track and incremental track $\alpha_{\text{therm}} \approx 8 \times 10^{-6} \text{ K}^{-1}$ (mounting type $\odot$ ); <i>with mounting spar</i> : $\alpha_{\text{therm}} \approx 9 \times 10^{-6} \text{ K}^{-1}$ (mounting type $\odot$ )		
<b>Accuracy grade*</b>	$\pm 3 \mu\text{m}$ ; $\pm 5 \mu\text{m}$		
<b>Measuring length ML*</b> in mm	Mounting spar* or clamping elements* optional 70 120 170 220 270 320 370 420 470 520 570 620 670 720 770 820 870 920 1020 1140 1240  Mounting spar* or clamping elements* necessary 1340 1440 1540 1640 1740 1840 2040		
<b>Absolute position values*</b>	EnDat 2.2 <i>Ordering designation</i> EnDat 02	Fanuc 02 serial interface	Mitsubishi high speed serial interface, Mit 02-4 or Mitsu 01
Resolution <i>Accuracy <math>\pm 3 \mu\text{m}</math></i> <i>Accuracy <math>\pm 5 \mu\text{m}</math></i>	0.005 $\mu\text{m}$ 0.01 $\mu\text{m}$	0.01 $\mu\text{m}$ 0.05 $\mu\text{m}$	
Calculation time $t_{\text{cal}}$ <i>EnDat 2.1 command set</i> <i>EnDat 2.2 command set</i>	< 1 ms $\leq 5 \mu\text{s}$	– –	
<b>Incremental signals</b>	$\sim 1 \text{ V}_{\text{PP}}^{1)}$	–	
Grating period/signal period	20 $\mu\text{m}$	–	
Cutoff frequency –3dB	$\geq 150 \text{ kHz}$	–	
<b>Power supply</b> without load	3.6 to 5.25 V/< 300 mA		
<b>Electrical connection</b>	Separate adapter cable (1 m/3 m/6 m/9 m) connectable to mounting block		
<b>Cable length</b> <sup>2)</sup>	$\leq 150 \text{ m}$ ; depending on the interface and subsequent electronics	$\leq 30 \text{ m}$	$\leq 20 \text{ m}$
<b>Traversing speed</b>	$\leq 180 \text{ m/min}$		
<b>Required moving force</b>	$\leq 5 \text{ N}$		
<b>Vibration</b> 55 to 2000 Hz	<i>Without mounting spar</i> : $\leq 100 \text{ m/s}^2$ (IEC 60068-2-6) <i>With mounting spar and cable outlet right/left</i> : $\leq 200 \text{ m/s}^2/100 \text{ m/s}^2$ (IEC 60068-2-6)		
<b>Shock</b> 11 ms <b>Acceleration</b>	$\leq 300 \text{ m/s}^2$ (IEC 60068-2-27) $\leq 100 \text{ m/s}^2$ in measuring direction		
<b>Operating temperature</b>	0 °C to 50 °C		
<b>Protection</b> IEC 60529	IP 53 when mounted according to the mounting instructions IP 64 if compressed air is connected via DA 300		
<b>Weight</b>	<i>Encoder</i> : 0.2 kg + 0.5 kg/m measuring length, <i>mounting spar</i> : 0.9 kg/m		

\* Please indicate when ordering  
1) Depending on the adapter cable

2) With HEIDENHAIN cable

# LC 100 Series

- Absolute linear encoders for measuring steps to 0.1 µm (resolution to 0.005 µm)
- High vibration rating
- Horizontal mounting possible
- Up to two additional scanning units are possible

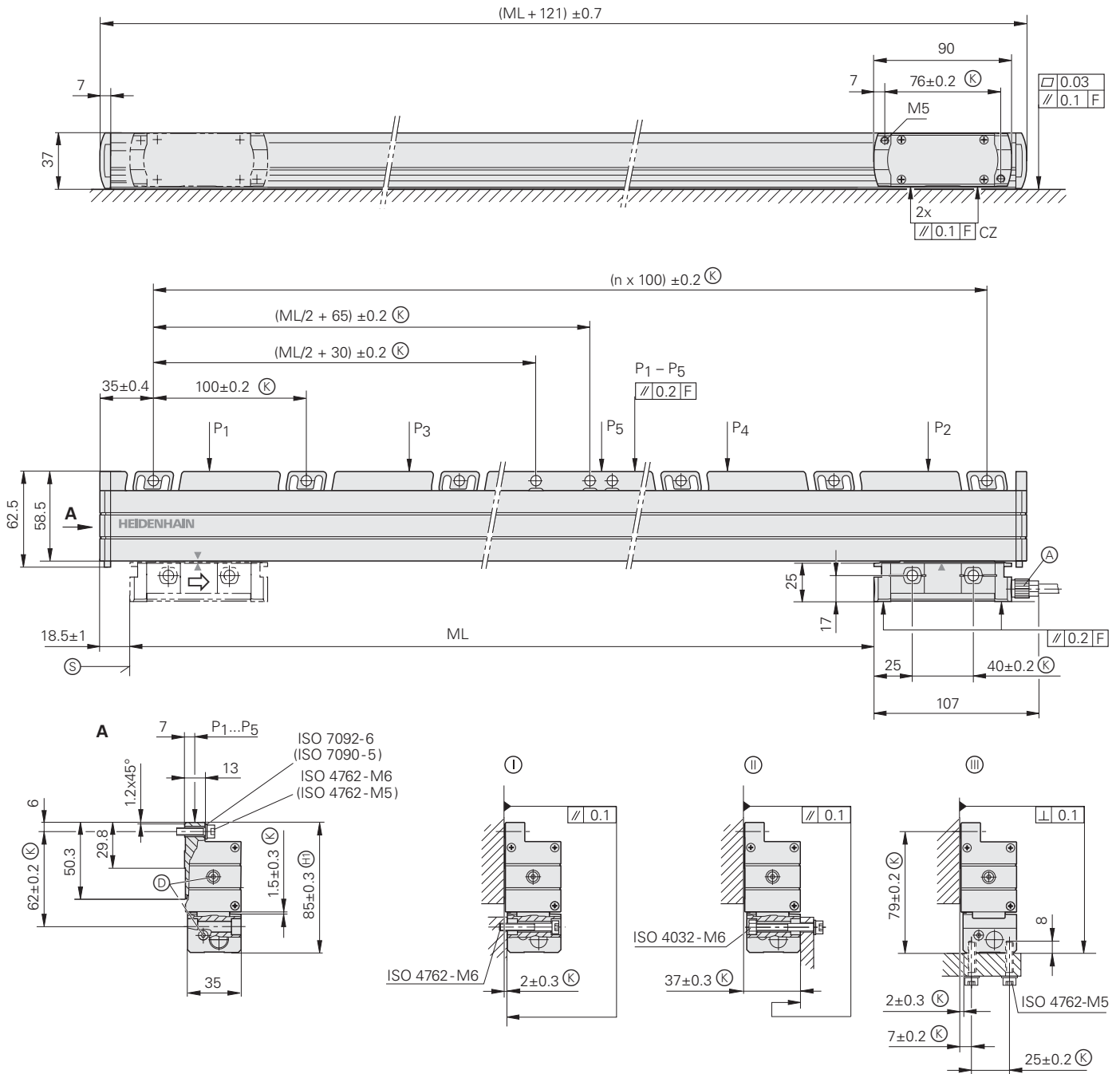

Dimensions in mm



Tolerancing ISO 8015

ISO 2768 - m H

< 6 mm: ±0.2 mm

⓪, Ⓜ,

Ⓜ = Mounting options

F = Machine guideway

P = Gauging points for alignment

Ⓐ = Cable connection usable at either end

Ⓚ = Required mating dimensions

Ⓛ = Compressed air inlet usable at either end

Ⓢ = Beginning of measuring length (ML)

Ⓜ = Alternative mating dimensions

⇒ = Direction of scanning unit motion for output signals in accordance with interface description



Specifications	LC 183	LC 193 F	LC 193 M											
<b>Measuring standard</b> Expansion coefficient	DIADUR glass scale with absolute track and incremental track $\alpha_{\text{therm}} \approx 8 \times 10^{-6} \text{ K}^{-1}$													
<b>Accuracy grade*</b>	$\pm 3 \mu\text{m}$ (up to measuring length 3040); $\pm 5 \mu\text{m}$													
<b>Measuring length ML*</b> in mm	140 1540 4040	240 1640 4240	340 1740	440 1840	540 2040	640 2240	740 2440	840 2640	940 2840	1040 3040	1140 3240	1240 3440	1340 3640	1440 3840
<b>Absolute position values*</b>	EnDat 2.2 <i>Ordering designation</i> EnDat 02		Fanuc 02 serial interface	Mitsubishi high speed serial interface, Mit 02-4 or Mitsu 01										
Resolution <i>Accuracy <math>\pm 3 \mu\text{m}</math></i> <i>Accuracy <math>\pm 5 \mu\text{m}</math></i>	0.005 $\mu\text{m}$ 0.01 $\mu\text{m}$		0.01 $\mu\text{m}$ 0.05 $\mu\text{m}$											
Calculation time $t_{\text{cal}}$ <i>EnDat 2.1 command set</i> <i>EnDat 2.2 command set</i>	< 1 ms $\leq 5 \mu\text{s}$		– –											
<b>Incremental signals</b>	$\sim 1 \text{ V}_{\text{PP}}^{1)}$		–											
Grating period/signal period	20 $\mu\text{m}$		–											
Cutoff frequency –3dB	$\geq 150 \text{ kHz}$		–											
<b>Power supply</b> without load	3.6 to 5.25 V/< 300 mA													
<b>Electrical connection</b>	Separate adapter cable (1 m/3 m/6 m/9 m) connectable to either side of mounting block													
<b>Cable length<sup>2)</sup></b>	$\leq 150 \text{ m}$ ; depending on the interface and subsequent electronics		$\leq 30 \text{ m}$	$\leq 20 \text{ m}$										
<b>Traversing speed</b>	$\leq 180 \text{ m/min}$													
<b>Required moving force</b>	$\leq 4 \text{ N}$													
<b>Vibration</b> 55 to 2000 Hz <b>Shock</b> 11 ms <b>Acceleration</b>	$\leq 200 \text{ m/s}^2$ (IEC 60068-2-6) $\leq 300 \text{ m/s}^2$ (IEC 60068-2-27) $\leq 100 \text{ m/s}^2$ in measuring direction													
<b>Operating temperature</b>	0 °C to 50 °C													
<b>Protection</b> IEC 60529	IP 53 when mounted according to the mounting instructions IP 64 if compressed air is connected via DA 300													
<b>Weight</b>	0.4 kg + 3.3 kg/m measuring length													

\* Please indicate when ordering

<sup>1)</sup> Depending on the adapter cable

<sup>2)</sup> With HEIDENHAIN cable

# LF 481

- Incremental linear encoder for measuring steps to 0.1  $\mu\text{m}$
- Thermal behavior similar to steel or cast iron
- For limited installation space

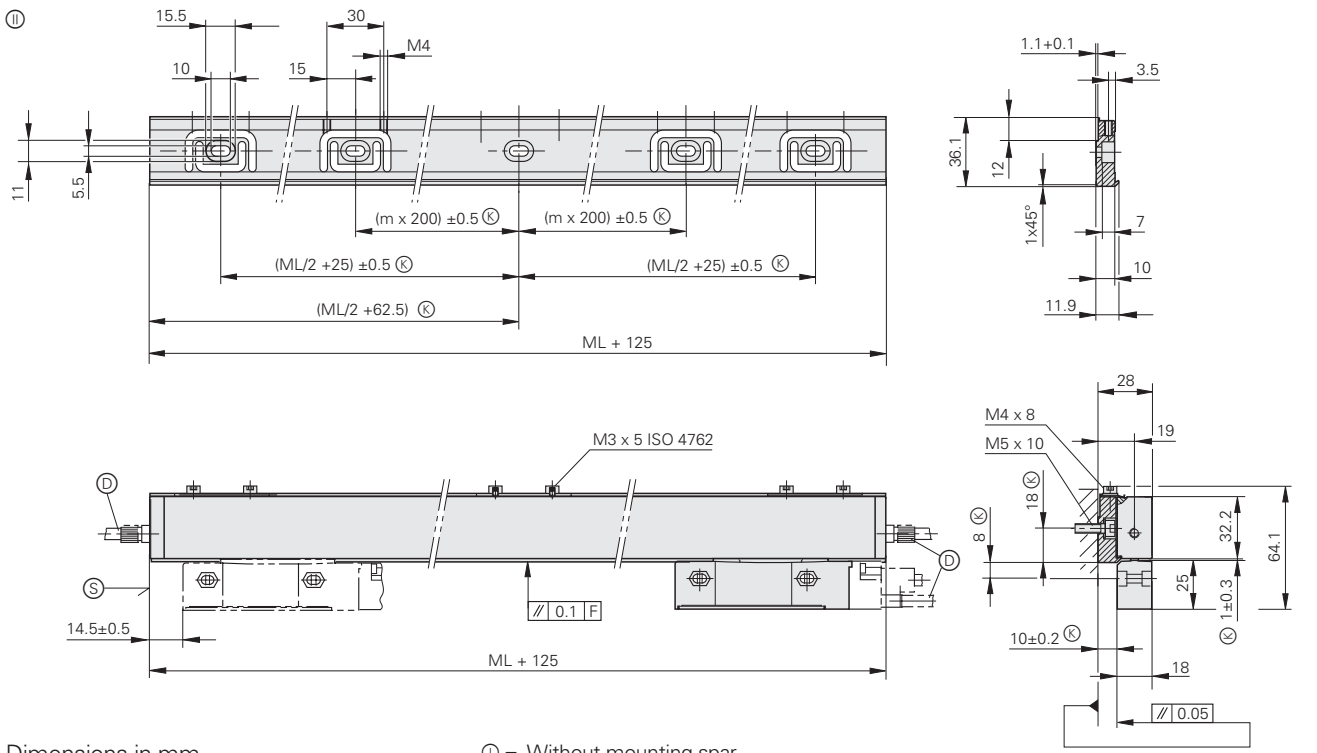
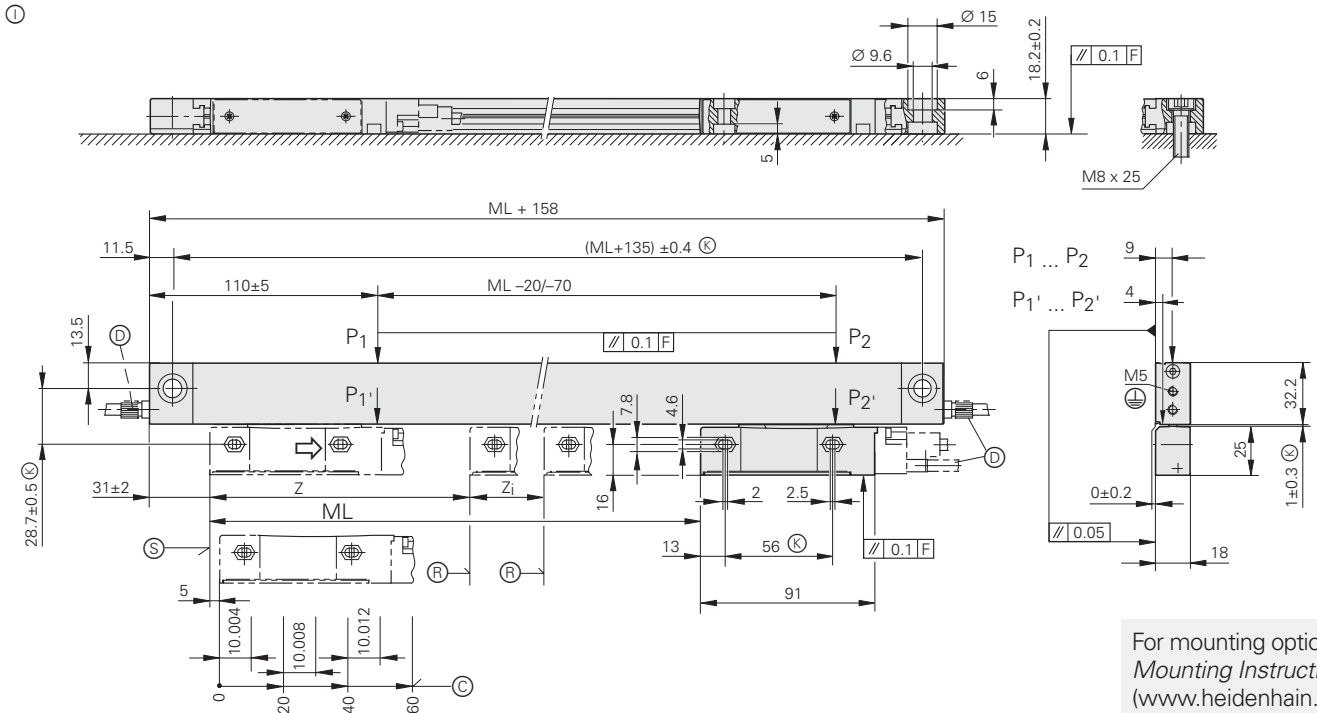

Dimensions in mm

Tolerancing ISO 8015  
 ISO 2768 - m H  
 < 6 mm:  $\pm 0.2$  mm

- ⊙ = Without mounting spar
  - ⊙ = With mounting spar
  - F = Machine guideway
  - P = Gauging points for alignment
  - ⊙ = Required mating dimensions
  - ⊙ = Compressed air inlet
  - ⊙ = Reference-mark position on LF 481  
2 reference marks for measuring lengths
- |                        |                        |
|------------------------|------------------------|
| 50 ... 1000            | 1120 ... 1220          |
| $z = 25$               | $z = 35$               |
| $z_i = \text{ML} - 50$ | $z_i = \text{ML} - 70$ |
- ⊙ = Reference-mark position on LF 481 C
  - ⊙ = Beginning of measuring length (ML)
  - ⇒ = Direction of scanning unit motion for output signals in accordance with interface description

**Mounting spar**

ML	m
50 ... 500	0
550 ... 900	1
1000 ... 1220	2





LF 481 without mounting spar

LF 481 with mounting spar

Specifications	LF 481
<b>Measuring standard</b> Expansion coefficient	DIADUR phase grating on steel $\alpha_{\text{therm}} \approx 10 \times 10^{-6} \text{ K}^{-1}$
<b>Accuracy grade*</b>	$\pm 3 \mu\text{m}; \pm 5 \mu\text{m}$
<b>Measuring length ML*</b> in mm	Mounting spar* recommended 50 100 150 200 250 300 350 400 450 500 550 600 650 700 750 800 900 1000 1120 1220
<b>Incremental signals</b>	$\sim 1 \text{ V}_{\text{PP}}$
Grating period Signal period	8 $\mu\text{m}$ 4 $\mu\text{m}$
Reference marks* LF 481 LF 481 C	ML 50 mm: 1 reference mark at midpoint ML 100 to 1000 mm: 2, located 25 mm from the beginning and end of the measuring length From ML 1120 mm: 2, located 35 mm from the beginning and end of the measuring length Distance-coded
Cutoff frequency -3dB	$\geq 200 \text{ kHz}$
<b>Power supply</b> without load	$5 \text{ V} \pm 5 \% < 200 \text{ mA}$
<b>Electrical connection</b>	Separate adapter cable (1 m/3 m/6 m/9 m) connectable to mounting block
<b>Cable length</b> <sup>1)</sup>	$\leq 150 \text{ m}$
<b>Traversing speed</b>	$\leq 30 \text{ m/min}$
<b>Required moving force</b>	$\leq 5 \text{ N}$
<b>Vibration</b> 55 to 2000 Hz <b>Shock</b> 11 ms <b>Acceleration</b>	$\leq 80 \text{ m/s}^2$ (IEC 60068-2-6) $\leq 100 \text{ m/s}^2$ (IEC 60068-2-27) $\leq 30 \text{ m/s}^2$ in measuring direction
<b>Operating temperature</b>	0 °C to 50 °C
<b>Protection</b> IEC 60529	IP 53 when mounted according to the mounting instructions IP 64 if compressed air is connected via DA 300
<b>Weight</b> without mounting spar	0.4 kg + 0.5 kg/m measuring length

\* Please indicate when ordering

<sup>1)</sup> With HEIDENHAIN cable

# LF 183

- Incremental linear encoder for measuring steps to 0.1 μm
- Thermal behavior similar to steel or cast iron
- High vibration rating
- Horizontal mounting possible

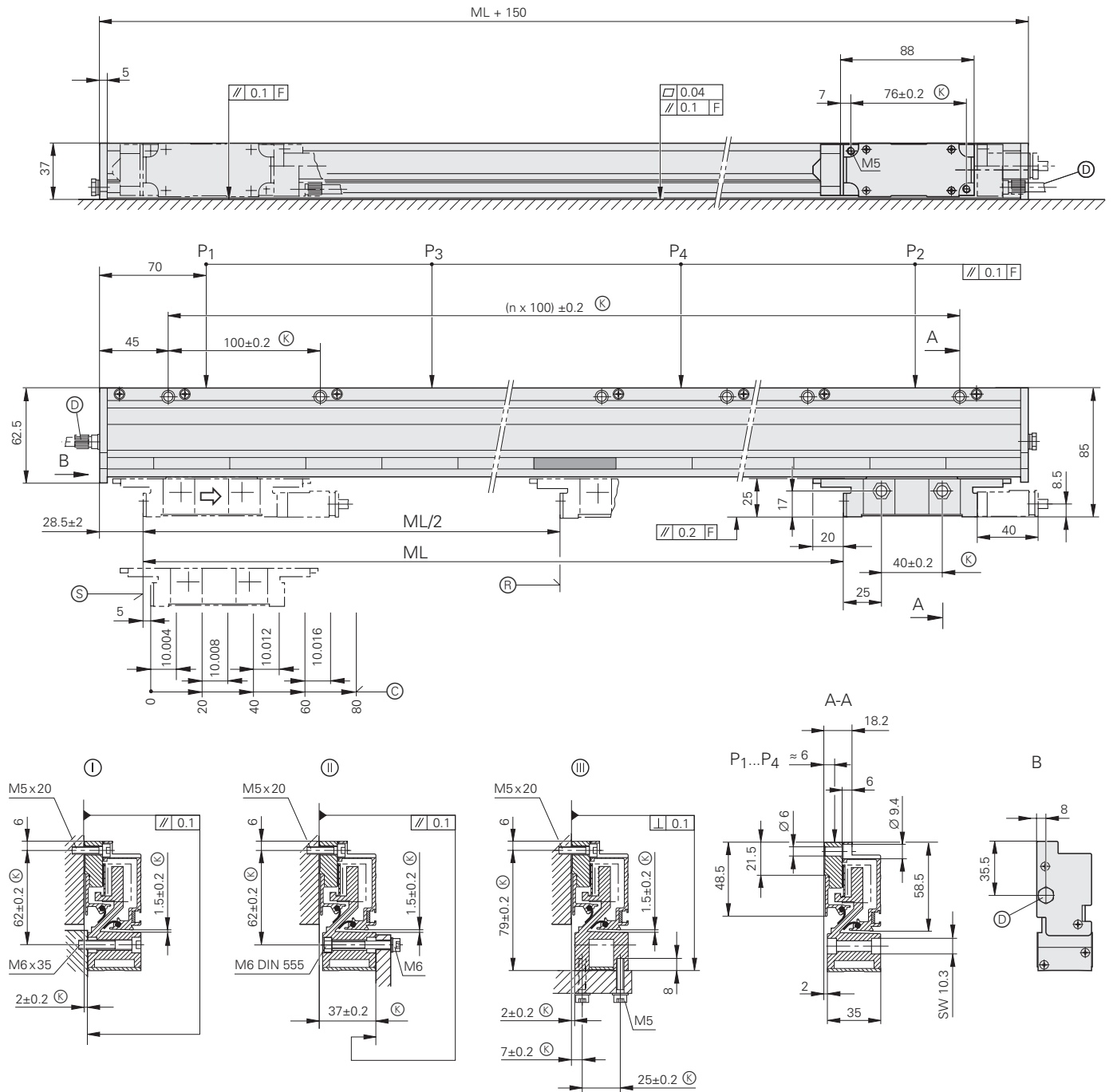

Dimensions in mm



Tolerancing ISO 8015  
ISO 2768 - m H  
< 6 mm: ±0.2 mm

⓪, ⓫,

⓬ = Mounting options

F = Machine guideway

P = Gauging points for alignment

Ⓜ = Required mating dimensions

Ⓝ = Compressed air inlet

Ⓞ = Reference-mark position on LF 183

Ⓟ = Reference-mark position on LF 183C

Ⓠ = Beginning of measuring length (ML)

⇒ = Direction of scanning unit motion for output signals in accordance with interface description



Specifications	LF 183
<b>Measuring standard</b> Expansion coefficient	DIADUR phase grating on steel $\alpha_{\text{therm}} \approx 10 \times 10^{-6} \text{ K}^{-1}$
<b>Accuracy grade*</b>	$\pm 3 \mu\text{m}; \pm 2 \mu\text{m}$
<b>Measuring length ML*</b> in mm	140 240 340 440 540 640 740 840 940 1040 1140 1240 1340 1440 1540 1640 1740 1840 2040 2240 2440 2640 2840 3040
<b>Incremental signals</b>	$\sim 1 V_{\text{PP}}$
Grating period Signal period	8 $\mu\text{m}$ 4 $\mu\text{m}$
Reference marks* <i>LF 183</i> <i>LF 183C</i>	Selectable with magnets every 50 mm Standard setting: 1 reference mark at midpoint of measuring length Distance-coded
Cutoff frequency -3dB	$\geq 200 \text{ kHz}$
<b>Power supply</b> without load	5V $\pm 5 \%$ / < 200 mA
<b>Electrical connection</b>	Separate adapter cable (1 m/3 m/6 m/9 m) connectable to mounting block
<b>Cable length</b> <sup>1)</sup>	$\leq 150 \text{ m}$
<b>Traversing speed</b>	$\leq 60 \text{ m/min}$
<b>Required moving force</b>	$\leq 4 \text{ N}$
<b>Vibration</b> 55 to 2000 Hz <b>Shock</b> 11 ms <b>Acceleration</b>	$\leq 150 \text{ m/s}^2$ (IEC 60068-2-6) $\leq 300 \text{ m/s}^2$ (IEC 60068-2-27) $\leq 100 \text{ m/s}^2$ in measuring direction
<b>Operating temperature</b>	0 °C to 40 °C
<b>Protection</b> IEC 60529	IP 53 when mounted according to the mounting instructions IP 64 if compressed air is connected via DA 300
<b>Weight</b>	1.1 kg + 3.8 kg/m measuring length

\* Please indicate when ordering

<sup>1)</sup> With HEIDENHAIN cable

# LS 400 Series

- Incremental linear encoder for measuring steps to 0.5  $\mu\text{m}$
- For limited installation space

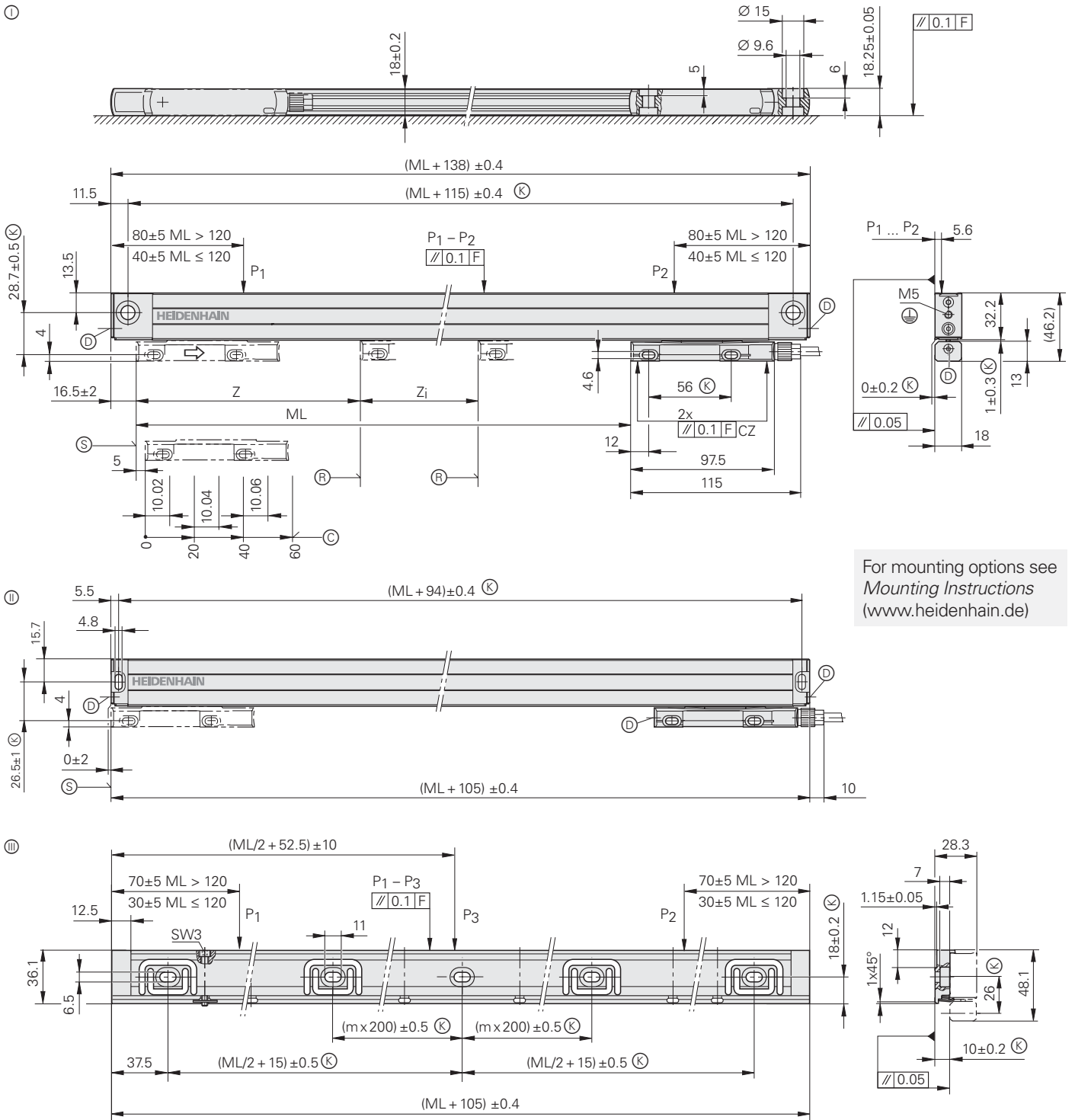

For mounting options see  
*Mounting Instructions*  
([www.heidenhain.de](http://www.heidenhain.de))

Dimensions in mm



Tolerancing ISO 8015  
ISO 2768 - m H  
< 6 mm:  $\pm 0.2$  mm

- ⊖ = Without mounting spar (with M8 screws)
- ⊕ = Short end piece, as replacement for predecessor with and without mounting spar. If attached directly with M4 screws, than specifications are restricted.
- ⊗ = With mounting spar

F = Machine guideway  
P = Gauging points for alignment  
ML  $\leq$  820 P<sub>1</sub> - P<sub>2</sub>  
ML > 820 P<sub>1</sub> - P<sub>3</sub>

- Ⓚ = Required mating dimensions
  - Ⓛ = Compressed air inlet
  - Ⓜ = Reference-mark position on LS 4x7  
1 reference mark at midpoint of measuring length ML = 70  
2 reference marks for measuring lengths
- |                          |                          |
|--------------------------|--------------------------|
| 120 ... 1020             | 1140 ... 2040            |
| Z = 35                   | Z = 45                   |
| Z <sub>i</sub> = ML - 70 | Z <sub>i</sub> = ML - 90 |
- Ⓝ = Reference-mark position on LS 4x7C

Ⓧ = Beginning of measuring length (ML)  
⇒ = Direction of scanning unit motion for output signals in accordance with interface description

### Mounting spar

ML	m
70 ... 520	0
570 ... 920	1
1020 ... 1340	2
1440 ... 1740	3
1840 ... 2040	4



LS 4x7 without mounting spar



LS 4x7 with mounting spar

Specifications	LS 487	LS 477						
<b>Measuring standard</b> Expansion coefficient	Glass scale with DIADUR graduation $\alpha_{\text{therm}} \approx 8 \times 10^{-6} \text{ K}^{-1}$ (mounting type ①/②); <i>with mounting spar</i> : $\alpha_{\text{therm}} \approx 9 \times 10^{-6} \text{ K}^{-1}$ (mounting type ③)							
<b>Accuracy grade*</b>	$\pm 5 \mu\text{m}$ ; $\pm 3 \mu\text{m}$							
<b>Measuring length ML*</b> in mm	Mounting spar* optional 70 120 170 220 270 320 370 420 470 520 570 620 670 720 770 820 870 920 1020 1140 1240 Mounting spar* necessary 1340 1440 1540 1640 1740 1840 2040							
Reference marks* LS 4x7  LS 4x7C	Selectable with magnets every 50 mm Standard: ML 70 mm: 1 in the center, up to ML 1020 mm: 2, each 35 mm from beginning/end of ML, from ML 1140 mm: 2, each 45 mm from beginning/end of ML Distance-coded							
<b>Incremental signals</b>	$\sim 1 \text{ V}_{\text{PP}}$	$\square$ TTL x 5		$\square$ TTL x 10			$\square$ TTL x 20	
Grating period Integrated interpolation* Signal period	20 $\mu\text{m}$ – 20 $\mu\text{m}$	20 $\mu\text{m}$ 5-fold 4 $\mu\text{m}$	20 $\mu\text{m}$ 10-fold 2 $\mu\text{m}$	20 $\mu\text{m}$ 20-fold 1 $\mu\text{m}$				
Cutoff frequency –3dB	$\geq 160 \text{ kHz}$	–		–			–	
Scanning frequency* Edge separation a	–	100 kHz $\geq 0.5 \mu\text{s}$	50 kHz $\geq 1 \mu\text{s}$	100 kHz $\geq 0.25 \mu\text{s}$	50 kHz $\geq 0.5 \mu\text{s}$	25 kHz $\geq 1 \mu\text{s}$	50 kHz $\geq 0.25 \mu\text{s}$	25 kHz $\geq 0.5 \mu\text{s}$
<b>Measuring step</b>	0.5 $\mu\text{m}$ <sup>1)</sup>	1 $\mu\text{m}$ <sup>2)</sup>		0.5 $\mu\text{m}$ <sup>2)</sup>			0.25 $\mu\text{m}$ <sup>2)</sup>	
<b>Traversing speed</b>	$\leq 120 \text{ m/min}$	$\leq 120 \text{ m/min}$	$\leq 60 \text{ m/min}$	$\leq 120 \text{ m/min}$	$\leq 60 \text{ m/min}$	$\leq 30 \text{ m/min}$	$\leq 60 \text{ m/min}$	$\leq 30 \text{ m/min}$
<b>Power supply</b> without load	5 V $\pm 5 \%$ / < 120 mA		5 V $\pm 5 \%$ / < 140 mA					
<b>Electrical connection</b>	Separate adapter cable (1 m/3 m/6 m/9 m) connectable to mounting block							
<b>Cable length</b> <sup>3)</sup>	$\leq 150 \text{ m}$		$\leq 100 \text{ m}$					
<b>Required moving force</b>	$\leq 5 \text{ N}$							
<b>Vibration</b> 55 to 2000 Hz <b>Shock</b> 11 ms <b>Acceleration</b>	<i>Without mounting spar</i> : $\leq 100 \text{ m/s}^2$ (IEC 60068-2-6) <i>With mounting spar and cable outlet right/left</i> : $\leq 200 \text{ m/s}^2/100 \text{ m/s}^2$ (IEC 60068-2-6) $\leq 300 \text{ m/s}^2$ (IEC 60068-2-27) $\leq 100 \text{ m/s}^2$ in measuring direction							
<b>Operating temperature</b>	0 °C to 50 °C							
<b>Protection</b> IEC 60529	IP 53 when installed according to mounting instructions, IP 64 with compressed air from DA 300							
<b>Weight</b>	0.4 kg + 0.5 kg/m measuring length							

\* Please indicate when ordering

<sup>2)</sup> After 4-fold evaluation in the evaluation electronics

<sup>1)</sup> Recommended for position measurement

<sup>3)</sup> With HEIDENHAIN cable





Specifications	LS 187	LS 177												
<b>Measuring standard</b> Expansion coefficient	Glass scale with DIADUR graduation $\alpha_{\text{therm}} \approx 8 \times 10^{-6} \text{ K}^{-1}$													
<b>Accuracy grade*</b>	$\pm 5 \mu\text{m}; \pm 3 \mu\text{m}$													
<b>Measuring length ML*</b> in mm	140 1540	240 1640	340 1740	440 1840	540 2040	640 2240	740 2440	840 2640	940 2840	1040 3040	1140	1240	1340	1440
Reference marks* <i>LS 1x7</i> <i>LS 1x7C</i>	Selectable with magnets every 50 mm, standard setting: 1 reference mark in the center Distance-coded													
<b>Incremental signals</b>	$\sim 1 \text{ V}_{\text{pp}}$		$\square$ TTL x 5		$\square$ TTL x 10			$\square$ TTL x 20						
Grating period	20 $\mu\text{m}$		20 $\mu\text{m}$		20 $\mu\text{m}$			20 $\mu\text{m}$						
Integrated interpolation*	–		5-fold		10-fold			20-fold						
Signal period	20 $\mu\text{m}$		4 $\mu\text{m}$		2 $\mu\text{m}$			1 $\mu\text{m}$						
Cutoff frequency –3dB	$\geq 160 \text{ kHz}$		–		–			–						
Scanning frequency* Edge separation a	–		100 kHz $\geq 0.5 \mu\text{s}$	50 kHz $\geq 1 \mu\text{s}$	100 kHz $\geq 0.25 \mu\text{s}$	50 kHz $\geq 0.5 \mu\text{s}$	25 kHz $\geq 1 \mu\text{s}$	50 kHz $\geq 0.25 \mu\text{s}$	25 kHz $\geq 0.5 \mu\text{s}$					
<b>Measuring step</b>	0.5 $\mu\text{m}^{1)}$		1 $\mu\text{m}^{2)}$		0.5 $\mu\text{m}^{2)}$			0.25 $\mu\text{m}^{2)}$						
<b>Traversing speed</b>	$\leq 120 \text{ m/min}$		$\leq 120 \text{ m/min}$	$\leq 60 \text{ m/min}$	$\leq 120 \text{ m/min}$	$\leq 60 \text{ m/min}$	$\leq 30 \text{ m/min}$	$\leq 60 \text{ m/min}$	$\leq 30 \text{ m/min}$					
<b>Power supply</b> without load	5 V $\pm 5 \%$ / $< 120 \text{ mA}$		5 V $\pm 5 \%$ / $< 140 \text{ mA}$											
<b>Electrical connection</b>	Separate adapter cable (1 m/3 m/6 m/9 m) connectable to mounting block													
<b>Cable length</b> <sup>3)</sup>	$\leq 150 \text{ m}$		$\leq 100 \text{ m}$											
<b>Required moving force</b>	$\leq 4 \text{ N}$													
<b>Vibration</b> 55 to 2000 Hz <b>Shock</b> 11 ms <b>Acceleration</b>	$\leq 200 \text{ m/s}^2$ (IEC 60068-2-6) $\leq 400 \text{ m/s}^2$ (IEC 60068-2-27) $\leq 60 \text{ m/s}^2$ in measuring direction													
<b>Operating temperature</b>	0 °C to 50 °C													
<b>Protection</b> IEC 60529	IP 53 when mounted according to the mounting instructions IP 64 if compressed air is connected via DA 300													
<b>Weight</b>	0.4 kg + 2.3 kg/m measuring length													

\* Please indicate when ordering

<sup>1)</sup> Recommended for position measurement

<sup>2)</sup> After 4-fold evaluation in the evaluation electronics

<sup>3)</sup> With HEIDENHAIN cable

# LB 382 up to 3040 mm Measuring Length (Single-Section Housing)

- Incremental linear encoder for measuring steps to 0.1 μm
- Horizontal mounting possible
- Mirror-image version available

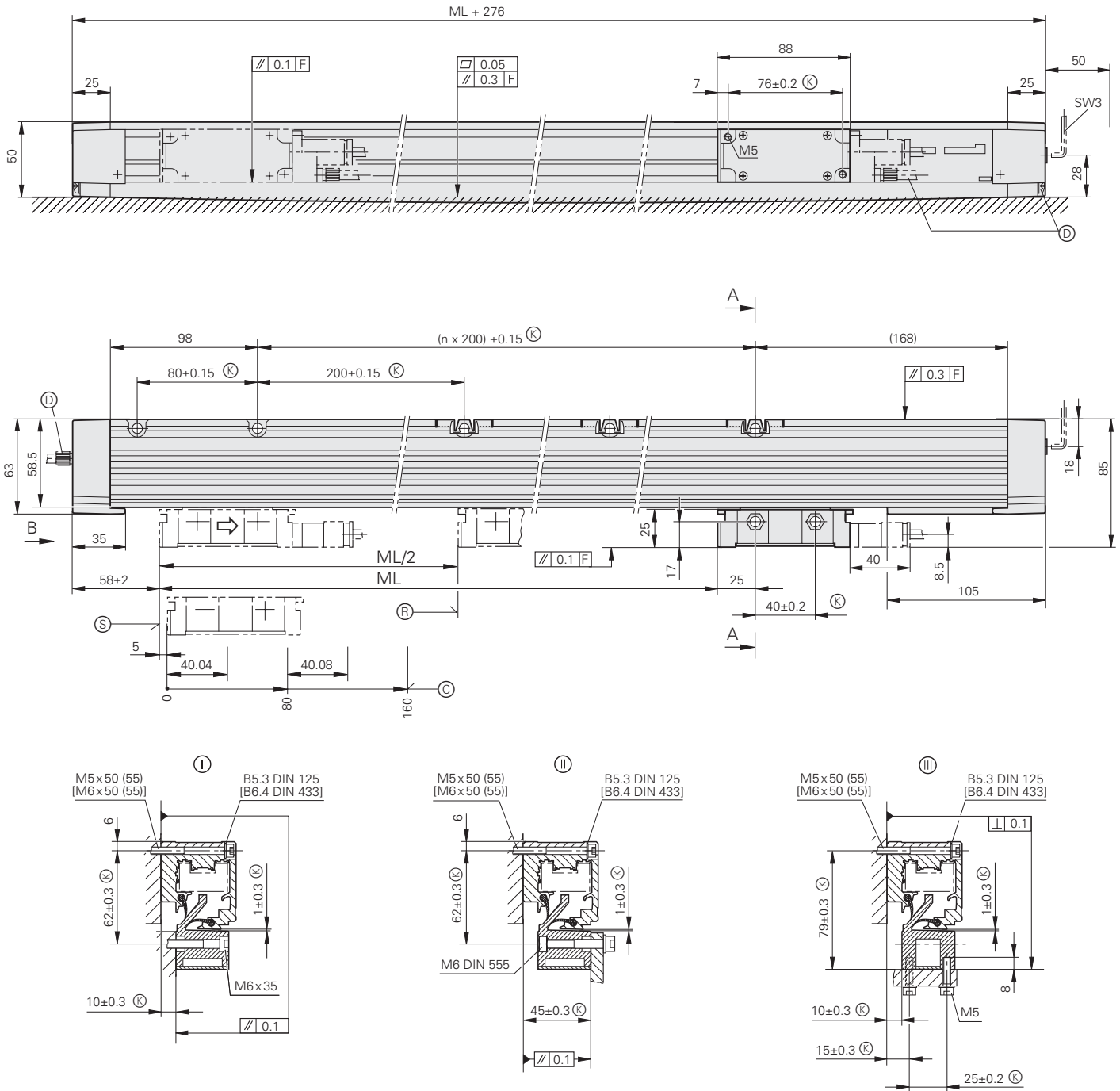

Dimensions in mm



Tolerancing ISO 8015  
ISO 2768 - m H  
< 6 mm: ±0.2 mm

- ⓪, Ⓛ, Ⓜ, = Mounting options
- F = Machine guideway
- Ⓞ = Required mating dimensions
- Ⓢ = Compressed air inlet
- Ⓟ = Reference-mark position on LB 3x2
- Ⓠ = Reference-mark position on LB 3x2C
- Ⓡ = Beginning of measuring length (ML)
- ⇒ = Direction of scanning unit motion for output signals in accordance with interface description

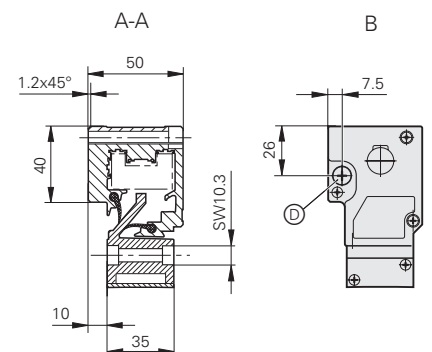





Specifications	LB 382 up to ML 3040 mm
<b>Measuring standard</b> Expansion coefficient	Stainless steel tape with AURODUR graduation $\alpha_{\text{therm}} \approx 10 \times 10^{-6} \text{ K}^{-1}$
<b>Accuracy grade</b>	$\pm 5 \mu\text{m}$
<b>Measuring length ML*</b> in mm	Single-section housing 440 640 840 1040 1240 1440 1640 1840 2040 2240 2440 2640 2840 3040
Reference marks* <i>LB 382</i> <i>LB 382 C</i>	Selectable with selector plates every 50 mm, standard setting: 1 reference mark in the center Distance-coded
<b>Incremental signals</b>	$\sim 1 \text{ V}_{\text{PP}}$
Grating period Signal period	40 $\mu\text{m}$ 40 $\mu\text{m}$
Cutoff frequency -3dB	$\geq 250 \text{ kHz}$
<b>Traversing speed</b>	$\leq 120 \text{ m/min}$
<b>Power supply</b> without load	$5 \text{ V} \pm 5 \% / < 150 \text{ mA}$
<b>Electrical connection</b>	Separate adapter cable (1 m/3 m/6 m/9 m) connectable to mounting block
<b>Cable length</b> <sup>1)</sup>	$\leq 150 \text{ m}$
<b>Required moving force</b>	$\leq 15 \text{ N}$
<b>Vibration</b> 55 to 2000 Hz <b>Shock</b> 11 ms <b>Acceleration</b>	$\leq 300 \text{ m/s}^2$ (IEC 60068-2-6) $\leq 300 \text{ m/s}^2$ (IEC 60068-2-27) $\leq 60 \text{ m/s}^2$ in measuring direction
<b>Operating temperature</b>	0 °C to 50 °C
<b>Protection</b> IEC 60529	IP 53 when mounted according to the mounting instructions IP 64 if compressed air is connected via DA 300
<b>Weight</b>	1.3 kg + 3.6 kg/m measuring length

\* Please indicate when ordering

<sup>1)</sup> With HEIDENHAIN cable

# LB 382 up to 30040 mm Measuring Length (Multi-Section Housing)

- Incremental linear encoder for long measuring ranges up to 30 m
- Measuring steps to 0.1  $\mu\text{m}$
- Horizontal mounting possible
- Mirror-image version available

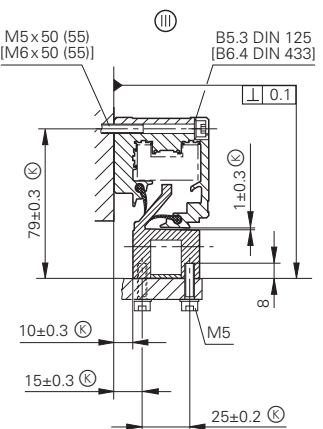
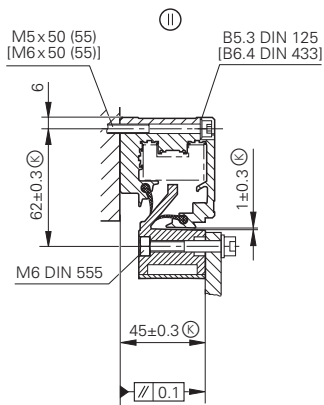
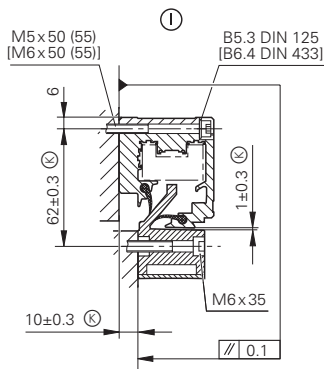
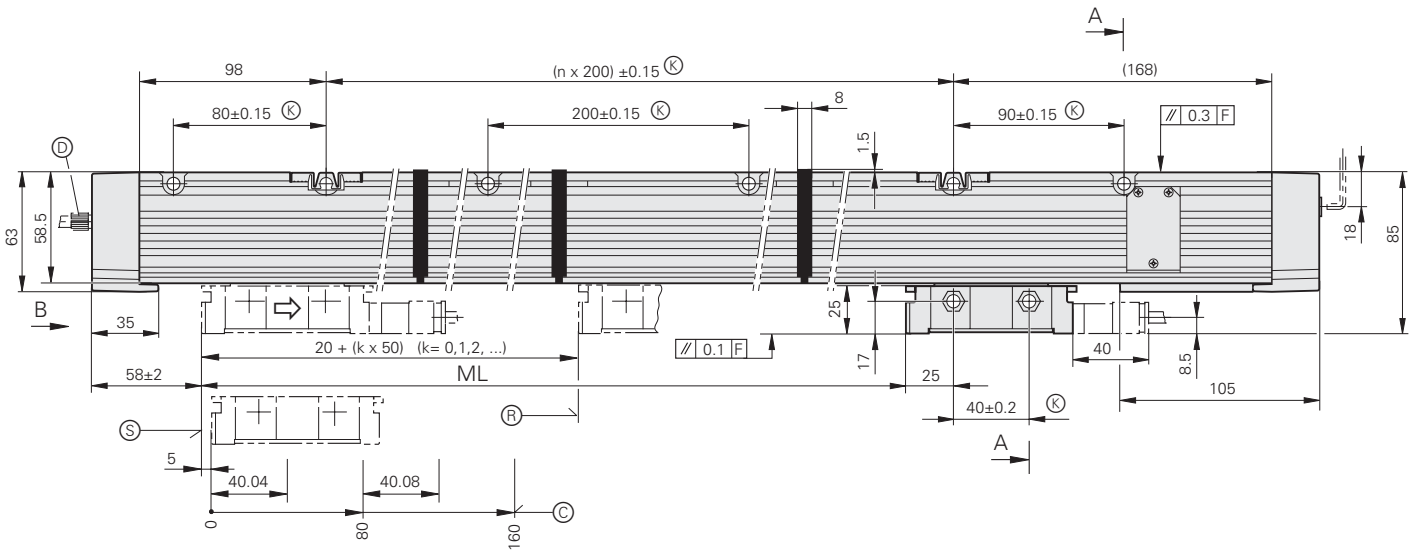
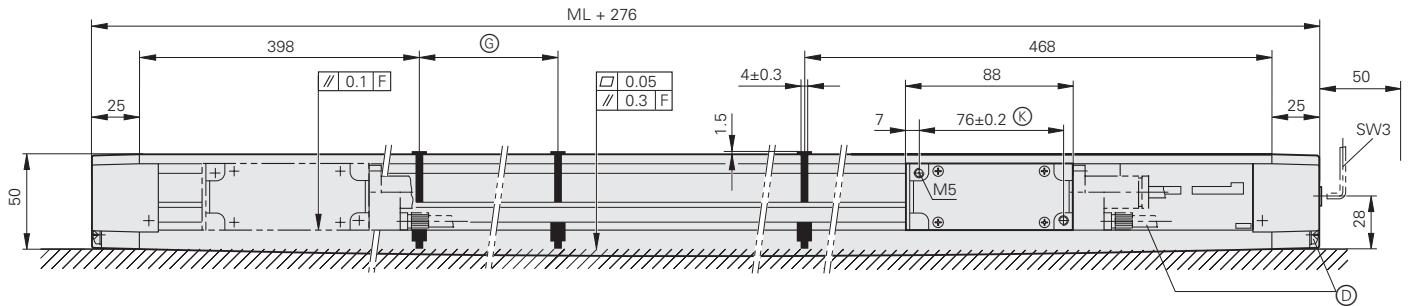

Dimensions in mm



Tolerancing ISO 8015  
ISO 2768 - m H  
< 6 mm:  $\pm 0.2$  mm

- ⓪, ⓑ, ⓓ = Mounting options
- F = Machine guideway
- ⓐ = Required mating dimensions
- ⓑ = Compressed air inlet
- ⓓ = Reference-mark position on LB 3x2
- ⓐ = Reference-mark position on LB 3x2C
- ⓑ = Beginning of measuring length (ML)
- ⓓ = Housing section lengths
- ⇒ = Direction of scanning unit motion for output signals in accordance with interface description

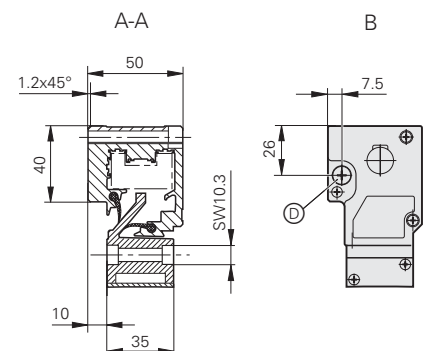



<b>Specifications</b>	<b>LB 382</b> from ML 3 240 mm
<b>Measuring standard</b> Expansion coefficient	Stainless steel tape with AURODUR graduation Same as machine main casting
<b>Accuracy grade</b>	$\pm 5 \mu\text{m}$
<b>Measuring length ML*</b>	Kit with single-section AURODUR steel tape and housing section lengths for measuring lengths from 3 240 mm to 30 040 mm in 200-mm steps. Housing section lengths: 1 000 mm, 1 200 mm, 1 400 mm, 1 600 mm, 1 800 mm, 2 000 mm
Reference marks* <i>LB 382</i> <i>LB 382 C</i>	Selectable with selector plates every 50 mm Distance-coded
<b>Incremental signals</b>	$\sim 1 V_{PP}$
Grating period Signal period	40 $\mu\text{m}$ 40 $\mu\text{m}$
Cutoff frequency -3dB	$\geq 250 \text{ kHz}$
<b>Traversing speed</b>	$\leq 120 \text{ m/min}$
<b>Power supply</b> without load	$5 V \pm 5 \% / < 150 \text{ mA}$
<b>Electrical connection</b>	Separate adapter cable (1 m/3 m/6 m/9 m) connectable to mounting block
<b>Cable length</b> <sup>1)</sup>	$\leq 150 \text{ m}$
<b>Required moving force</b>	$\leq 15 \text{ N}$
<b>Vibration</b> 55 to 2 000 Hz <b>Shock</b> 11 ms <b>Acceleration</b>	$\leq 300 \text{ m/s}^2$ (IEC 60 068-2-6) $\leq 300 \text{ m/s}^2$ (IEC 60 068-2-27) $\leq 60 \text{ m/s}^2$ in measuring direction
<b>Operating temperature</b>	0 °C to 50 °C
<b>Protection</b> IEC 60 529	IP 53 when mounted according to the mounting instructions IP 64 if compressed air is connected via DA 300
<b>Weight</b>	1.3 kg + 3.6 kg/m measuring length

\* Please indicate when ordering

<sup>1)</sup> With HEIDENHAIN cable

# Interfaces

## Incremental Signals $\sim 1 V_{PP}$

HEIDENHAIN encoders with  $\sim 1 V_{PP}$  interface provide voltage signals that can be highly interpolated.

The sinusoidal **incremental signals** A and B are phase-shifted by  $90^\circ$  elec. and have an amplitude of typically  $1 V_{PP}$ . The illustrated sequence of output signals—with B lagging A—applies for the direction of motion shown in the dimension drawing.

The **reference mark signal** R has a usable component *G* of approx.  $0.5 V$ . Next to the reference mark, the output signal can be reduced by up to  $1.7 V$  to a quiescent value *H*. This must not cause the subsequent electronics to overdrive. Even at the lowered signal level, signal peaks with the amplitude *G* can also appear.

The data on **signal amplitude** apply when the power supply given in the specifications is connected to the encoder. They refer to a differential measurement at the  $120 \text{ ohm}$  terminating resistor between the associated outputs. The signal amplitude decreases with increasing frequency. The **cutoff frequency** indicates the scanning frequency at which a certain percentage of the original signal amplitude is maintained:

- $-3 \text{ dB} \triangleq 70 \%$  of the signal amplitude
- $-6 \text{ dB} \triangleq 50 \%$  of the signal amplitude

The data in the signal description apply to motions at up to  $20\%$  of the  $-3 \text{ dB}$  cutoff frequency.

### Interpolation/resolution/measuring step

The output signals of the  $1 V_{PP}$  interface are usually interpolated in the subsequent electronics in order to attain sufficiently high resolutions. For **velocity control**, interpolation factors are commonly over  $1000$  in order to receive usable velocity information even at low speeds.

Measuring steps for **position measurement** are recommended in the specifications. For special applications, other resolutions are also possible.

### Short circuit stability

A temporary short circuit of one signal output to  $0 V$  or  $U_P$  (except encoders with  $U_{Pmin} = 3.6 V$ ) does not cause encoder failure, but it is not a permissible operating condition.

Short circuit at	$20^\circ C$	$125^\circ C$
One output	< 3 min	< 1 min
All outputs	< 20 s	< 5 s

Interface	Sinusoidal voltage signals $\sim 1 V_{PP}$
<b>Incremental signals</b>	<b>2 nearly sinusoidal signals A and B</b> Signal amplitude M: $0.6$ to $1.2 V_{PP}$ ; typically $1 V_{PP}$ Asymmetry $ P - N /2M$ : $\leq 0.065$ Signal ratio $M_A/M_B$ : $0.8$ to $1.25$ Phase angle $ \varphi_1 + \varphi_2 /2$ : $90^\circ \pm 10^\circ$ elec.
<b>Reference-mark signal</b>	<b>One or several signal peaks R</b> Usable component <i>G</i> : $\geq 0.2 V$ Quiescent value <i>H</i> : $\leq 1.7 V$ Switching threshold <i>E</i> , <i>F</i> : $0.04$ to $0.68 V$ Zero crossovers <i>K</i> , <i>L</i> : $180^\circ \pm 90^\circ$ elec.
<b>Connecting cable</b>	Shielded HEIDENHAIN cable PUR [ $4(2 \times 0.14 \text{ mm}^2) + (4 \times 0.5 \text{ mm}^2)$ ] max. $150 \text{ m}$ with $90 \text{ pF/m}$ distributed capacitance Cable length Propagation time $6 \text{ ns/m}$

These values can be used for dimensioning of the subsequent electronics. Any limited tolerances in the encoders are listed in the specifications. For encoders without integral bearing, reduced tolerances are recommended for initial servicing (see the mounting instructions).

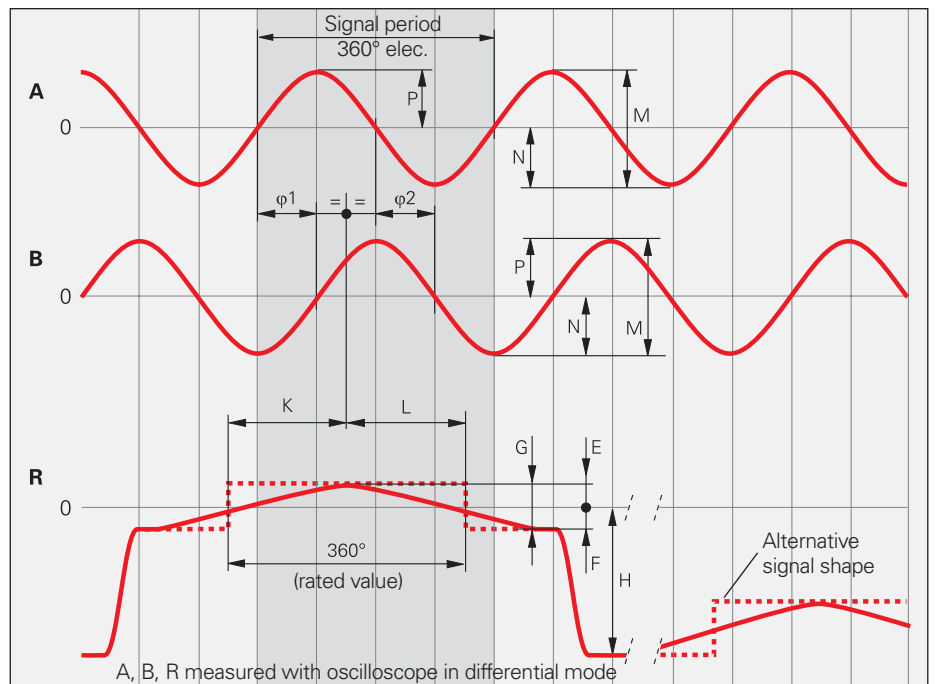

### Cutoff frequency

Typical signal amplitude curve with respect to the scanning frequency

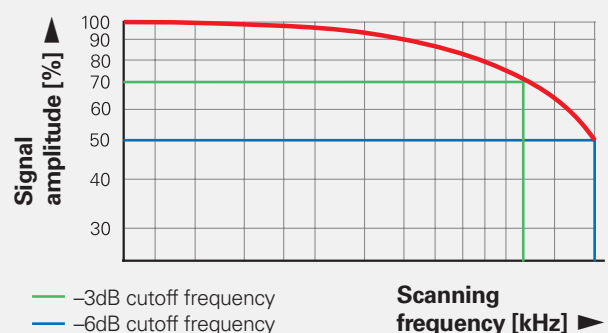

## Input circuitry of the subsequent electronics

### Dimensioning

Operational amplifier MC 34074

$Z_0 = 120 \Omega$

$R_1 = 10 \text{ k}\Omega$  and  $C_1 = 100 \text{ pF}$

$R_2 = 34.8 \text{ k}\Omega$  and  $C_2 = 10 \text{ pF}$

$U_B = \pm 15 \text{ V}$

$U_1$  approx.  $U_0$

### -3dB cutoff frequency of circuitry

approx. 450 kHz

Approx. 50 kHz and  $C_1 = 1000 \text{ pF}$   
and  $C_2 = 82 \text{ pF}$

The circuit variant for 50 kHz does reduce the bandwidth of the circuit, but in doing so it improves its noise immunity.

### Circuit output signals

$U_a = 3.48 V_{PP}$  typical

Gain 3.48

### Monitoring of the incremental signals

The following thresholds are recommended for monitoring of the signal level M:

Lower threshold:  $0.30 V_{PP}$

Upper threshold:  $1.35 V_{PP}$

### Incremental signals Reference-mark signal

$R_a < 100 \Omega$ , typ.  $24 \Omega$

$C_a < 50 \text{ pF}$

$\Sigma I_a < 1 \text{ mA}$

$U_0 = 2.5 \text{ V} \pm 0.5 \text{ V}$   
(relative to 0 V of the power supply)

### Encoder

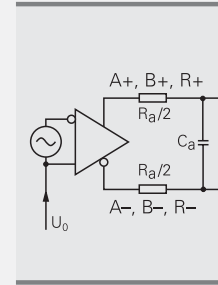

### Subsequent electronics

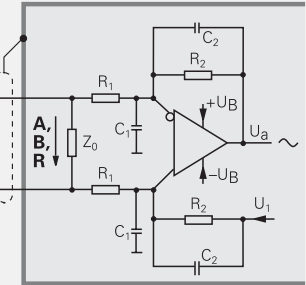

## Pin layout

12-pin M23 coupling		12-pin M23 connector		15-pin D-sub connector, female for HEIDENHAIN controls and IK 220									
Power supply				Incremental signals						Other signals			
	12	2	10	11	5	6	8	1	3	4	7/9	/	/
	1	9	2	11	3	4	6	7	10	12	5/8/13/14/15	/	/
	$U_P$	Sensor $U_P$	0V	Sensor 0V	A+	A-	B+	B-	R+	R-	Vacant	Vacant	Vacant
	Brown/ Green	Blue	White/ Green	White	Brown	Green	Gray	Pink	Red	Black	/	Violet	Yellow

**Cable shield** connected to housing;  $U_P$  = power supply voltage

**Sensor:** The sensor line is connected internally with the corresponding power line

Vacant pins or wires must not be used!

# Interfaces

## Incremental Signals TTL

HEIDENHAIN encoders with  TTL interface incorporate electronics that digitize sinusoidal scanning signals with or without interpolation.

The **incremental signals** are transmitted as the square-wave pulse trains  $U_{a1}$  and  $U_{a2}$ , phase-shifted by  $90^\circ$  elec. The **reference mark signal** consists of one or more reference pulses  $U_{a0}$ , which are gated with the incremental signals. In addition, the integrated electronics produce their **inverse signals**  $\overline{U_{a1}}$ ,  $\overline{U_{a2}}$  and  $\overline{U_{a0}}$  for noise-proof transmission. The illustrated sequence of output signals—with  $U_{a2}$  lagging  $U_{a1}$ —applies for the direction of motion shown in the dimension drawing.

The **fault-detection signal**  $\overline{U_{aS}}$  indicates fault conditions such as breakage of the power line or failure of the light source. It can be used for such purposes as machine shut-off during automated production.

The distance between two successive edges of the incremental signals  $U_{a1}$  and  $U_{a2}$  through 1-fold, 2-fold or 4-fold evaluation is one **measuring step**.

The subsequent electronics must be designed to detect each edge of the square-wave pulse. The minimum **edge separation  $a$**  listed in the *Specifications* applies for the illustrated input circuitry with a cable length of 1 m, and refers to a measurement at the output of the differential line receiver. Cable-dependent differences in the propagation times additionally reduce the edge separation by 0.2 ns per meter of cable. To prevent counting error, design the subsequent electronics to process as little as 90% of the resulting edge separation. The max. permissible **shaft speed** or **traversing velocity** must never be exceeded.

The permissible **cable length** for transmission of the TTL square-wave signals to the subsequent electronics depends on the edge separation  $a$ . It is max. 100 m, or 50 m for the fault detection signal. This requires, however, that the power supply (see *Specifications*) be ensured at the encoder. The sensor lines can be used to measure the voltage at the encoder and, if required, correct it with an automatic system (remote sense power supply).

<b>Interface</b>	Square-wave signals  TTL
<b>Incremental signals</b>	<b>2 TTL square-wave signals <math>U_{a1}</math>, <math>U_{a2}</math></b> and their inverted signals $\overline{U_{a1}}$ , $\overline{U_{a2}}$
<b>Reference-mark signal</b> Pulse width Delay time	<b>1 or more TTL square-wave pulses <math>U_{a0}</math></b> and their inverted pulses $\overline{U_{a0}}$ $90^\circ$ elec. (other widths available on request); LS 323: ungated $ t_d  \leq 50$ ns
<b>Fault-detection signal</b> Pulse width	<b>1 TTL square-wave pulse <math>\overline{U_{aS}}</math></b> Improper function: LOW (upon request: $U_{a1}/U_{a2}$ high impedance) Proper function: HIGH $t_S \geq 20$ ms
<b>Signal level</b>	Differential line driver as per EIA standard RS 422 $U_H \geq 2.5$ V at $-I_H = 20$ mA $U_L \leq 0.5$ V at $I_L = 20$ mA
<b>Permissible load</b>	$Z_0 \geq 100 \Omega$ between associated outputs $ I_L  \leq 20$ mA max. load per output $C_{load} \leq 1000$ pF with respect to 0 V Outputs protected against short circuit to 0 V
<b>Switching times</b> (10% to 90%)	$t_r / t_f \leq 30$ ns (typically 10 ns) with 1 m cable and recommended input circuitry
<b>Connecting cable</b> Cable length Propagation time	Shielded HEIDENHAIN cable PUR [ $4(2 \times 0.14 \text{ mm}^2) + (4 \times 0.5 \text{ mm}^2)$ ] Max. 100 m ( $\overline{U_{aS}}$ max. 50 m) with 90 pF/m distributed capacitance 6 ns/m

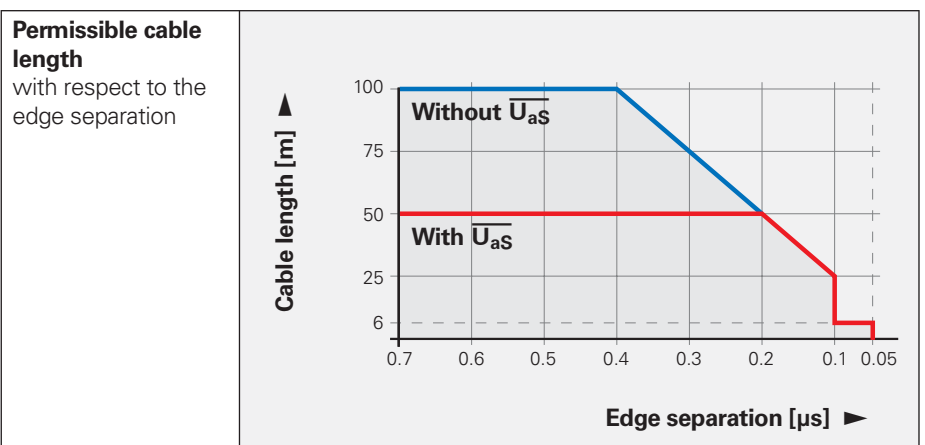
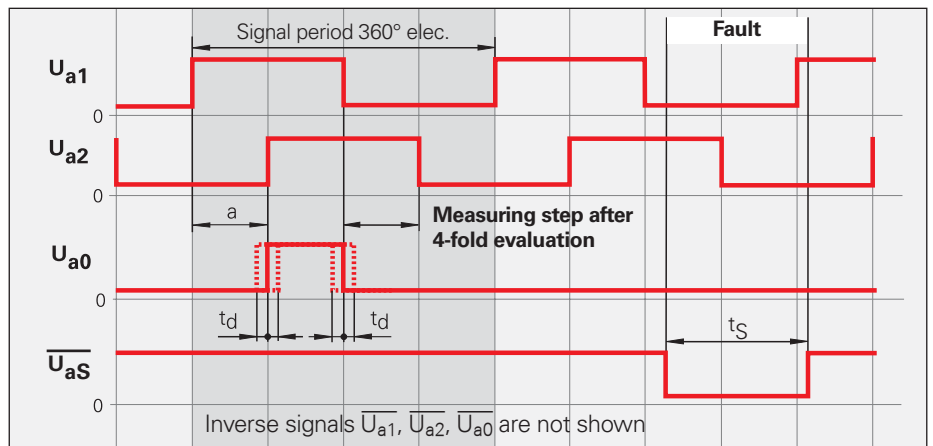

## Input circuitry of the subsequent electronics

### Dimensioning

IC<sub>1</sub> = Recommended differential line receivers  
 DS 26 C 32 AT  
 Only for a > 0.1 μs:  
 AM 26 LS 32  
 MC 3486  
 SN 75 ALS 193

R<sub>1</sub> = 4.7 kΩ  
 R<sub>2</sub> = 1.8 kΩ  
 Z<sub>0</sub> = 120 Ω  
 C<sub>1</sub> = 220 pF (serves to improve noise immunity)

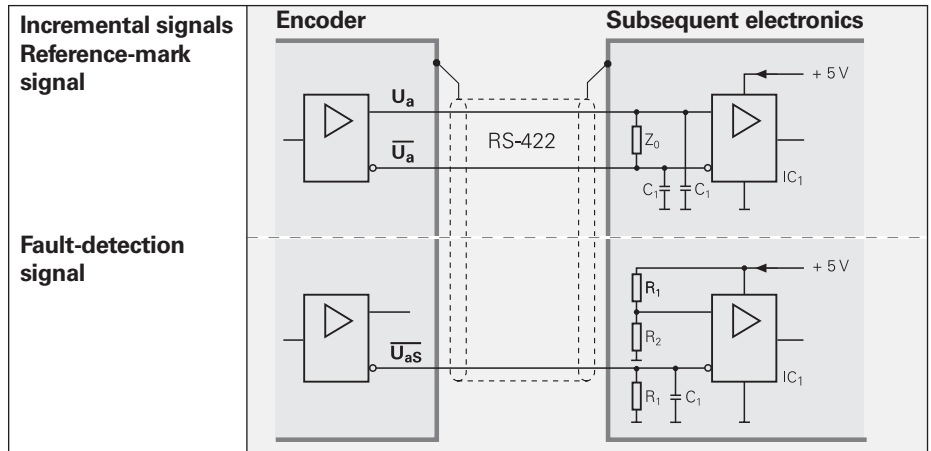

## Pin layout

12-pin flange socket or M23 coupling					12-pin M23 connector								
Power supply					Incremental signals						Other signals		
12	2	10	11	5	6	8	1	3	4	7	/	9	
U <sub>P</sub>	Sensor U <sub>P</sub>	0V	Sensor 0V	U <sub>a1</sub>	U <sub>a1</sub> <sup>-</sup>	U <sub>a2</sub>	U <sub>a2</sub> <sup>-</sup>	U <sub>a0</sub>	U <sub>a0</sub> <sup>-</sup>	U <sub>aS</sub> <sup>-1)</sup>	Vacant	Vacant <sup>2)</sup>	
Brown/Green	Blue	White/Green	White	Brown	Green	Gray	Pink	Red	Black	Violet	-	Yellow	

**Cable shield** connected to housing; **U<sub>P</sub>** = power supply voltage

**Sensor:** The sensor line is connected internally with the corresponding power line

<sup>1)</sup> **LS 323/ERO 14xx:** Vacant

<sup>2)</sup> **Exposed linear encoders:** TTL/11 μA<sub>PP</sub> conversion for PWT, otherwise vacant

Vacant pins or wires must not be used!



# Interfaces

## Absolute Position Values

The EnDat interface is a digital, **bidirectional** interface for encoders. It is capable of transmitting **position values** from both absolute and—with EnDat 2.2—incremental encoders, as well as reading and updating information stored in the encoder, or of saving new information. Thanks to the **serial transmission method**, only **four signal lines** are required. The data is transmitted in **synchronism** with the CLOCK signal from the subsequent electronics. The type of transmission (position values, parameters, diagnostics, etc.) is selected by mode commands that the subsequent electronics send to the encoder.

### Clock frequency and cable length

Without propagation-delay compensation, the **clock frequency**—depending on the cable length—is variable between **100 kHz** and **2 MHz**.

Because large cable lengths and high clock frequencies increase the signal run time to the point that they can disturb the unambiguous assignment of data, the delay can be measured in a test run and then compensated. With this **propagation-delay compensation** in the subsequent electronics, clock frequencies up to **16 MHz** at cable lengths up to a maximum of 100 m ( $f_{CLK} \leq 8 \text{ MHz}$ ) are possible. The maximum clock frequency is mainly determined by the cables and connecting elements used. To ensure proper function at clock frequencies above 2 MHz, use only original ready-made HEIDENHAIN cables.

Interface	EnDat serial bidirectional
Data transfer	Absolute position values, parameters and additional information
Data input	Differential line receiver according to EIA standard RS 485 for the CLOCK, $\overline{\text{CLOCK}}$ , DATA and $\overline{\text{DATA}}$ signals.
Data output	Differential line driver according to EIA standard RS 485 for the DATA and $\overline{\text{DATA}}$ signals.
Code	Pure binary code
Position values	Ascending during traverse in direction of arrow (see dimensions of the encoders)
Incremental signals	$\sim 1 V_{PP}$ (see <i>Incremental signals 1 V<sub>PP</sub></i> ) depending on unit
Connecting cable	Shielded HEIDENHAIN cable With Incremental signals PUR [(4 × 0.14 mm <sup>2</sup> ) + 4(2 × 0.14 mm <sup>2</sup> ) + (4 × 0.5 mm <sup>2</sup> )] Without signals PUR [(4 × 0.14 mm <sup>2</sup> ) + (4 × 0.34 mm <sup>2</sup> )]
Cable length	Max. 150 m
Propagation time	Max. 10 ns; typ. 6 ns/m

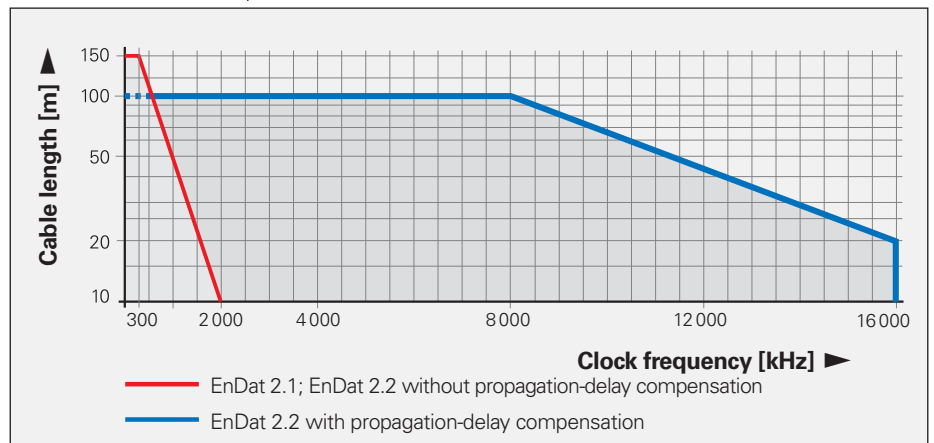

### Input Circuitry of the Subsequent Electronics

#### Dimensioning

IC<sub>1</sub> = RS 485 differential line receiver and driver

C<sub>3</sub> = 330 pF  
Z<sub>0</sub> = 120 Ω

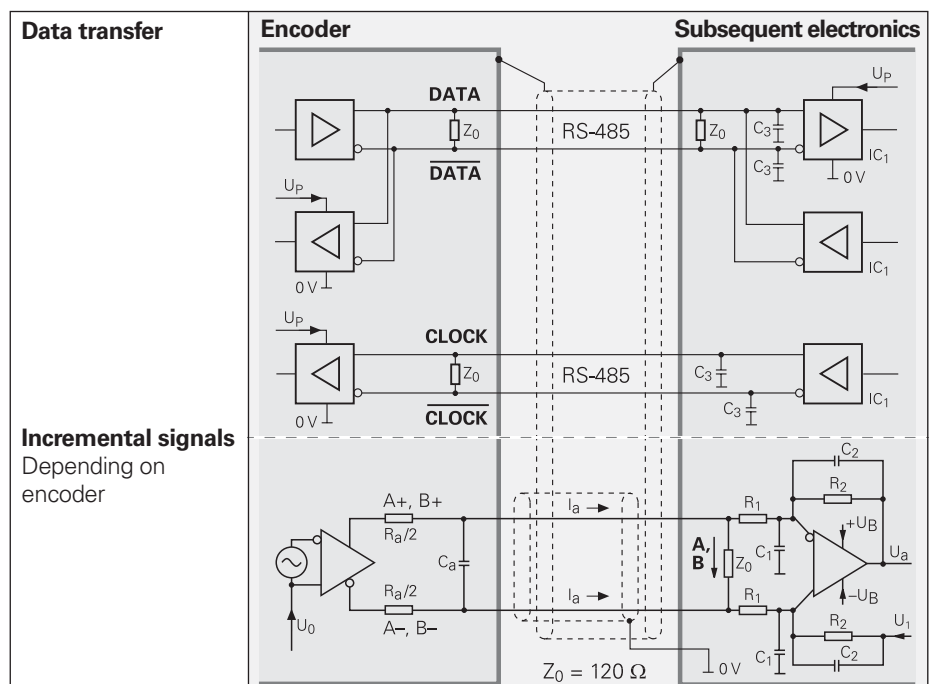



## Benefits of the EnDat Interface

- **Automatic self-configuration:** All information required by the subsequent electronics is already stored in the encoder.
- **High system security** through alarms and messages for monitoring and diagnosis.
- **High transmission reliability** through cyclic redundancy checks.
- **Datum shift** for faster commissioning.

## Other benefits of EnDat 2.2

- **A single interface** for all absolute and incremental encoders.
- **Additional information** (limit switch, temperature, acceleration)
- **Quality improvement:** Position value calculation in the encoder permits shorter sampling intervals (25 µs).
- **Online diagnostics** through valuation numbers that indicate the encoder's current functional reserves and make it easier to plan the machine servicing.
- **Safety concept** for designing safety-oriented control systems consisting of safe controls and safe encoders based on the DIN EN ISO 13 849-1 and IEC 61 508 standards.

## Advantages of purely serial transmission

specifically for EnDat 2.2 encoders

- **Cost optimization** through **simple subsequent electronics** with EnDat receiver component and **simple connection technology:** Standard connecting element (M12; 8-pin), single-shielded standard cables and low wiring cost.
- **Minimized transmission times** through **high clock frequencies** up to 16 MHz. Position values available in the subsequent electronics after only approx. 10 µs.
- **Support for state-of-the-art machine designs** e.g. direct drive technology.

Ordering designation	Command set	Incremental signals	Clock frequency	Power supply
<b>EnDat 01</b>	EnDat 2.1 or EnDat 2.2	With	≤ 2 MHz	See specifications of the encoder
EnDat 21		Without		
EnDat 02	EnDat 2.2	With	≤ 2 MHz	Expanded range 3.6 to 5.25 V or 14 V
<b>EnDat 22</b>	EnDat 2.2	Without	≤ 16 MHz	

Specification of the EnDat interface (bold print indicates standard versions)

## Versions

The extended EnDat interface version 2.2 is compatible in its communication, command set and time conditions with version 2.1, but also offers significant advantages. It makes it possible, for example, to transfer additional information with the position value without sending a separate request for it. The interface protocol was expanded and the time conditions (clock frequency, processing time, recovery time) were optimized.

## Ordering designation

Indicated on the ID label and can be read out via parameter.

## Command set

The command set is the sum of all available mode commands. (See "Selecting the transmission type"). The EnDat 2.2 command set includes EnDat 2.1 mode commands. When a mode command from the EnDat 2.2 command set is transmitted to EnDat-01 subsequent electronics, the encoder or the subsequent electronics may generate an error message.

## Incremental signals

EnDat 2.1 and EnDat 2.2 are both available with or without incremental signals. EnDat 2.2 encoders feature a high internal resolution. Therefore, depending on the control technology being used, interrogation of the incremental signals is not necessary. To increase the resolution of EnDat 2.1 encoders, the incremental signals are interpolated and evaluated in the subsequent electronics.

## Power supply

Encoders with ordering designations EnDat 02 and EnDat 22 have an extended power supply range.

## Functions

The EnDat interface transmits absolute position values or additional physical quantities (only EnDat 2.2) in an unambiguous time sequence and serves to read from and write to the encoder's internal memory. Some functions are available only with EnDat 2.2 mode commands.

**Position values** can be transmitted with or without additional information. The additional information types are selectable via the Memory Range Select (MRS) code. Other functions such as *Read parameter* and *Write parameter* can also be called after the memory area and address have been selected. Through simultaneous transmission with the position value, additional information can also be requested of axes in the feedback loop, and functions executed with them.

**Parameter** reading and writing is possible both as a separate function and in connection with the position value. Parameters can be read or written after the memory area and address is selected.

**Reset functions** serve to reset the encoder in case of malfunction. Reset is possible instead of or during position value transmission.

**Servicing diagnostics** make it possible to inspect the position value even at a standstill. A test command has the encoder transmit the required test values.

You can find more information in the *EnDat 2.2 Technical Information document* or on the Internet at [www.endat.de](http://www.endat.de).

## Selecting the Transmission Type

Transmitted data are identified as either position values, position values with additional information, or parameters. The type of information to be transmitted is selected by mode commands. **Mode commands** define the content of the transmitted information. Every mode command consists of three bits. To ensure reliable transmission, every bit is transmitted redundantly (inverted or double). The EnDat 2.2 interface can also transfer parameter values in the additional information together with the position value. This makes the current position values constantly available for the control loop, even during a parameter request.

## Control cycles for transfer of position values

The transmission cycle begins with the first falling **clock edge**. The measured values are saved and the position value calculated. After two clock pulses (2T), to **select the type of transmission**, the subsequent electronics transmit the mode command "Encoder transmit position value" (with/without additional information). The subsequent electronics continue to transmit clock pulses and observe the data line to detect the start bit. The **start bit** starts data transmission from the encoder to the subsequent electronics. Time  $t_{cal}$  is the smallest time duration after which the position value can be read by the encoder. The subsequent **error messages**, error 1 and error 2 (only with EnDat 2.2 commands), are group signals for all monitored functions and serve as failure monitors.

Beginning with the LSB, the encoder then transmits the absolute **position value** as a complete data word. Its length varies depending on which encoder is being used. The number of required clock pulses for transmission of a position value is saved in the parameters of the encoder manufacturer. The data transmission of the position value is completed with the **Cyclic Redundancy Check (CRC)**. In EnDat 2.2, this is followed by additional information 1 and 2, each also concluded with a CRC. With the end of the data word, the clock must be set to HIGH. After 10 to 30  $\mu$ s or 1.25 to 3.75  $\mu$ s (with EnDat 2.2 parameterizable recovery time  $t_m$ ) the data line falls back to LOW. Then a **new data transmission** can begin by starting the clock.

## Mode commands

<ul style="list-style-type: none"> <li>Encoder transmit position value</li> <li>Selection of memory area</li> <li>Encoder receive parameters</li> <li>Encoder transmit parameters</li> <li>Encoder receive reset<sup>1)</sup></li> <li>Encoder transmit test values</li> <li>Encoder receive test command</li> </ul>	EnDat 2.1	EnDat 2.2
<ul style="list-style-type: none"> <li>Encoder transmit position value with additional information</li> <li>Encoder transmit position value and receive selection of memory area<sup>2)</sup></li> <li>Encoder transmit position value and receive parameters<sup>2)</sup></li> <li>Encoder transmit position value and transmit parameters<sup>2)</sup></li> <li>Encoder transmit position value and receive error reset<sup>2)</sup></li> <li>Encoder transmit position value and receive test command<sup>2)</sup></li> <li>Encoder receive communication command<sup>3)</sup></li> </ul>		

<sup>1)</sup> Same reaction as switching the power supply off and on

<sup>2)</sup> Selected additional information is also transmitted

<sup>3)</sup> Reserved for encoders that do not support the safety system

The time absolute linear encoders need for calculating the position values  $t_{cal}$  differs depending on whether EnDat 2.1 or EnDat 2.2 mode commands are transmitted (see *Specifications* in the *Linear Encoders for Numerically Controlled Machine Tools* brochure). If the incremental signals are evaluated for axis control, then the EnDat 2.1 mode commands should be used. Only in this manner can an active error message be transmitted synchronously with the currently requested position value. EnDat 2.1 mode commands should not be used for purely serial position value transfer for axis control.

		Without delay compensation	With delay compensation
<b>Clock frequency</b>	$f_c$	100 kHz ... 2 MHz	100 kHz ... 16 MHz
<b>Calculation time for Position value Parameters</b>	$t_{cal}$ $t_{ac}$	See <i>Specifications</i> Max. 12 ms	
<b>Recovery time</b>	$t_m$	<i>EnDat 2.1</i> : 10 to 30 $\mu$ s <i>EnDat 2.2</i> : 10 to 30 $\mu$ s or 1.25 to 3.75 $\mu$ s ( $f_c \geq 1$ MHz) (parameterizable)	
	$t_R$	Max. 500 ns	
	$t_{ST}$	–	2 to 10 $\mu$ s
<b>Data delay time</b>	$t_D$	(0.2 + 0.01 x cable length in m) $\mu$ s	
<b>Pulse width</b>	$t_{HI}$	0.2 to 10 $\mu$ s	Pulse width fluctuation HIGH to LOW max. 10%
	$t_{LO}$	0.2 to 50 ms/30 $\mu$ s (with LC)	

## EnDat 2.2 – Transmission of Position Values

EnDat 2.2 can transmit position values with or without additional information.

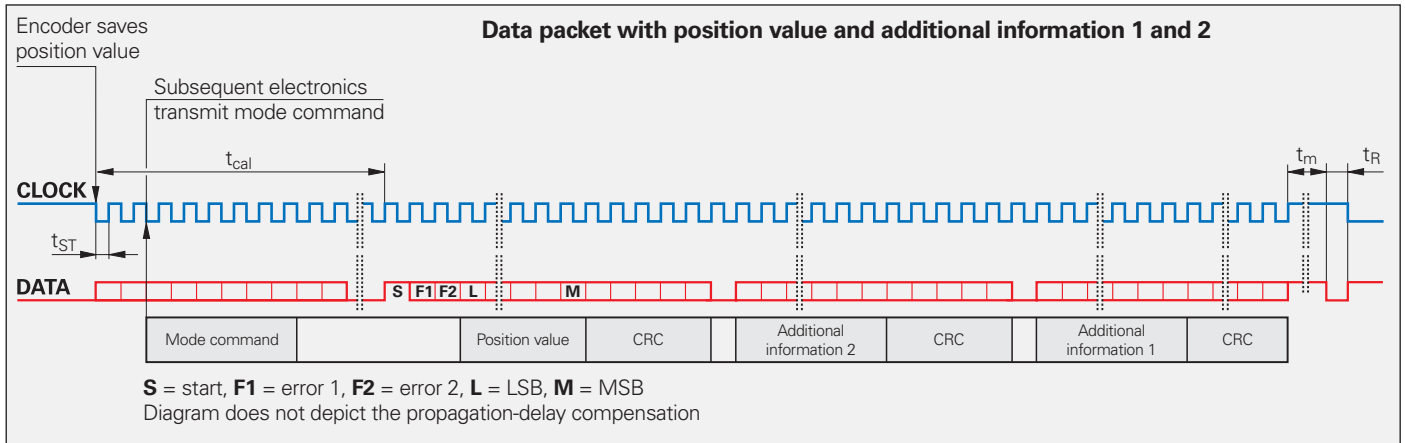
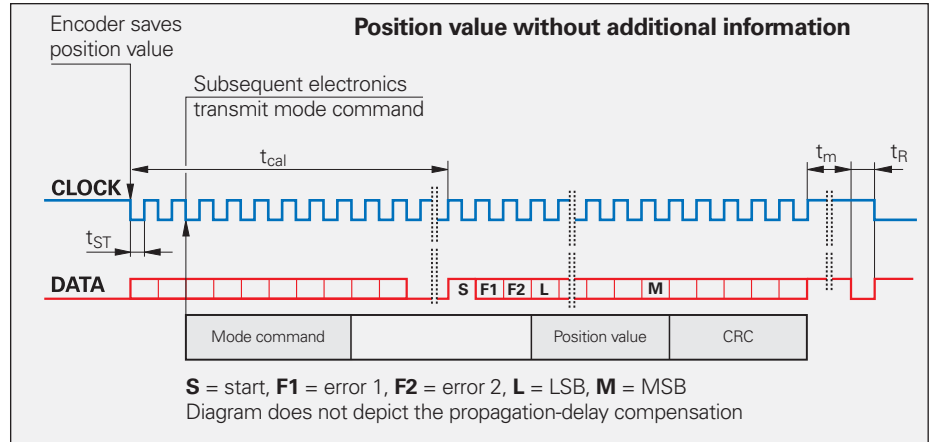

### Additional information

With EnDat 2.2, one or two pieces of additional information can be appended to the position value. Each additional information is 30 bits long with LOW as first bit, and ends with a CRC check. The additional information supported by the respective encoder is saved in the encoder parameters.

The content of the additional information is determined by the MRS code and is transmitted in the next sampling cycle for additional information. This information is then transmitted with every sampling until a selection of a new memory area changes the content.

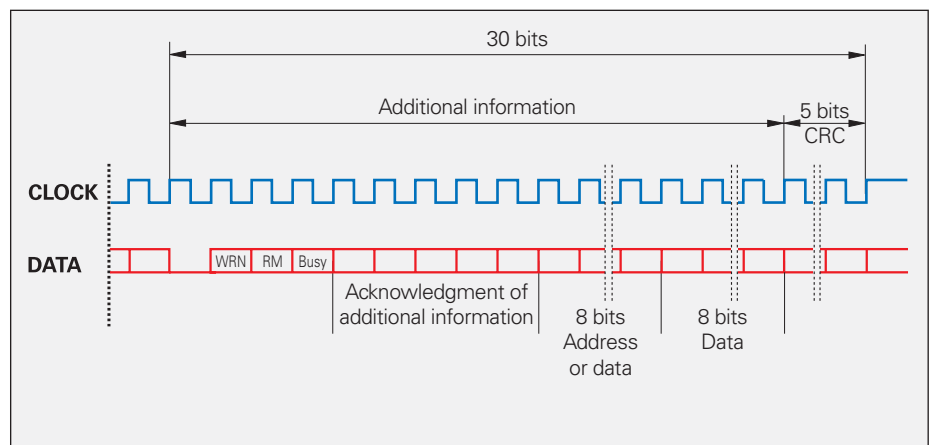

The additional information always begins with:

**Status data**  
Warning – WRN  
RM – Reference mark  
Parameter request – Busy  
**Acknowledgment** of additional information

The additional information can contain the following data:

**Additional information 1**  
Diagnosis (valuation numbers)  
Position value 2  
Memory parameters  
MRS-code acknowledgment  
Test values  
Encoder temperature  
External temperature sensors  
Sensor data

**Additional information 2**  
Commutation  
Acceleration  
Limit position signals  
Operating status error sources

## EnDat 2.1 – Transmission of Position Values

EnDat 2.1 can transmit position values with interrupted clock pulse (as in EnDat 2.2) or continuous clock pulse.

### Interrupted clock

The interrupted clock is intended particularly for time-clocked systems such as closed control loops. At the end of the data word the clock signal is set to HIGH level. After 10 to 30  $\mu\text{s}$  ( $t_m$ ), the data line falls back to LOW. A new data transmission can then begin when started by the clock.

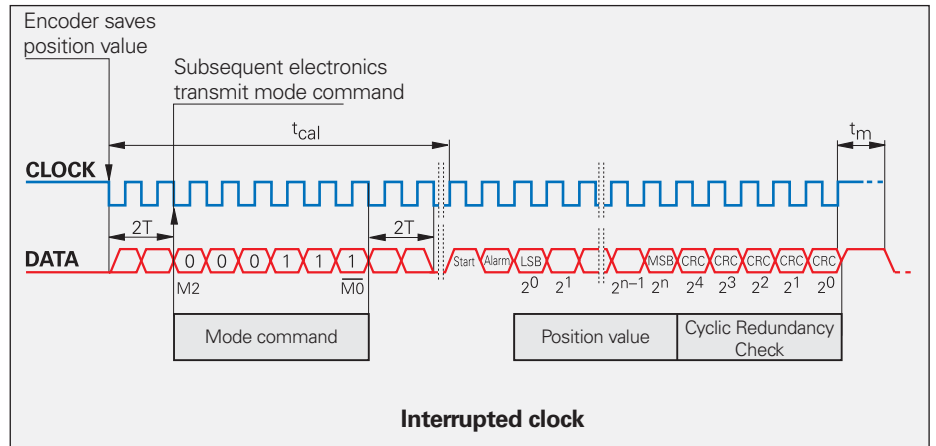

### Continuous clock

For applications that require fast acquisition of the measured value, the EnDat interface can have the clock run continuously. Immediately after the last CRC bit has been sent, the data line is switched to HIGH for one clock cycle, and then to LOW. The new position value is saved with the very next falling edge of the clock and is output in synchronism with the clock signal immediately after the start bit and alarm bit. Because the mode command *Encoder transmit position value* is needed only before the first data transmission, the continuous-clock transfer mode reduces the length of the clock-pulse group by 10 periods per position value.

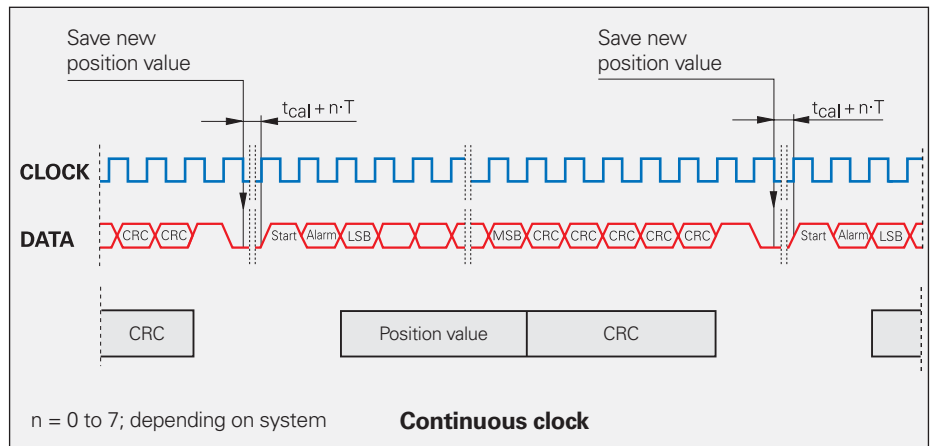

### Synchronization of the serially transmitted code value with the incremental signal

Absolute encoders with EnDat interface can exactly synchronize serially transmitted absolute position values with incremental values. With the first falling edge (latch signal) of the CLOCK signal from the subsequent electronics, the scanning signals of the individual tracks in the encoder and counter are frozen, as are the A/D converters for subdividing the sinusoidal incremental signals in the subsequent electronics.

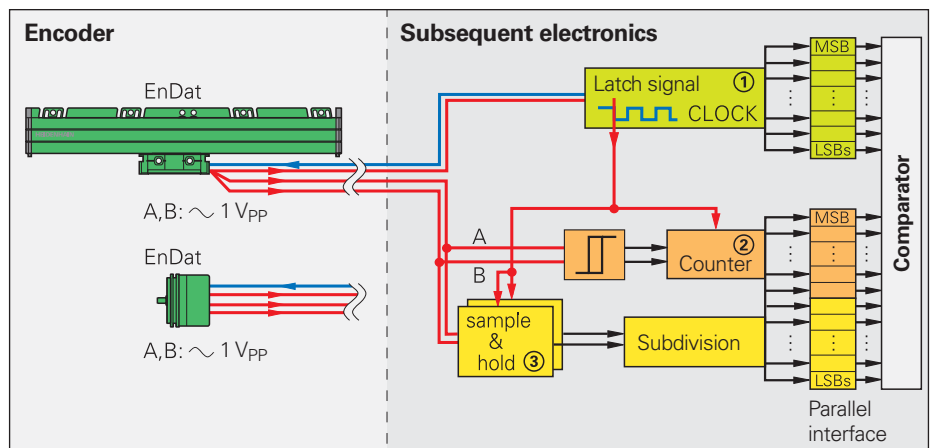

The code value transmitted over the serial interface unambiguously identifies one incremental signal period. The position value is absolute within one sinusoidal period of the incremental signal. The subdivided incremental signal can therefore be appended in the subsequent electronics to the serially transmitted code value.

After power on and initial transmission of position values, two redundant position values are available in the subsequent electronics. Since encoders with EnDat interface guarantee a precise synchronization—regardless of cable length—of the serially transmitted code value with the incremental

signals, the two values can be compared in the subsequent electronics. This monitoring is possible even at high shaft speeds thanks to the EnDat interface's short transmission times of less than 50  $\mu\text{s}$ . This capability is a prerequisite for modern machine design and safety systems.

## Parameters and Memory Areas

The encoder provides several memory areas for parameters. These can be read from by the subsequent electronics, and some can be written to by the encoder manufacturer, the OEM, or even the end user. Certain memory areas can be write-protected.

 The parameters, which in most cases are set by the OEM, largely define the function of the encoder and the EnDat interface. When the encoder is exchanged, it is therefore essential that its parameter settings are correct. Attempts to configure machines without including OEM data can result in malfunctions. If there is any doubt as to the correct parameter settings, the OEM should be consulted.

### Parameters of the encoder manufacturer

This write-protected memory area contains all **information specific to the encoder**, such as encoder type (linear/angular, singleturn/multiturn, etc.), signal periods, position values per revolution, transmission format of position values, direction of rotation, maximum speed, accuracy dependent on shaft speeds, warnings and alarms, ID number and serial number. This information forms the basis for **automatic configuration**. A separate memory area contains the parameters typical for EnDat 2.2: Status of additional information, temperature, acceleration, support of diagnostic and error messages, etc.

### Parameters of the OEM

In this freely definable memory area, the OEM can store his information, e.g. the “electronic ID label” of the motor in which the encoder is integrated, indicating the motor model, maximum current rating, etc.

### Operating parameters

This area is available for a **datum shift**, the configuration of diagnostics and for instructions. It can be protected against overwriting.

### Operating status

This memory area provides detailed alarms or warnings for diagnostic purposes. Here it is also possible to initialize certain encoder functions, activate write protection for the OEM parameter and operating parameter memory areas, and to interrogate their status. Once activated, **the write protection** cannot be reversed.

## Monitoring and Diagnostic Functions

The EnDat interface enables comprehensive monitoring of the encoder without requiring an additional transmission line. The alarms and warnings supported by the respective encoder are saved in the “parameters of the encoder manufacturer” memory area.

### Error message

An error message becomes active if a **malfunction of the encoder** might result in incorrect position values. The exact cause of the disturbance is saved in the encoder’s “operating status” memory. Interrogation via the “Operating status error sources” additional information is also possible. Here the EnDat interface transmits the error 1 and error 2 error bits (only with EnDat 2.2 commands). These are group signals for all monitored functions and serve for failure monitoring. The two error messages are generated independently from each other.

### Warning

This collective bit is transmitted in the status data of the additional information. It indicates that certain **tolerance limits of the encoder** have been reached or exceeded—such as shaft speed or the limit of light source intensity compensation through voltage regulation—without implying that the measured position values are incorrect. This function makes it possible to issue preventive warnings in order to minimize idle time.

### Online diagnostics

Encoders with purely serial interfaces do not provide incremental signals for evaluation of encoder function. EnDat 2.2 encoders can therefore cyclically transmit so-called valuation numbers from the encoder. The valuation numbers provide the current state of the encoder and ascertain the encoder’s “functional reserves.” The identical scale for all HEIDENHAIN encoders allows uniform valuation. This makes it easier to plan machine use and servicing.

### Cyclic Redundancy Check

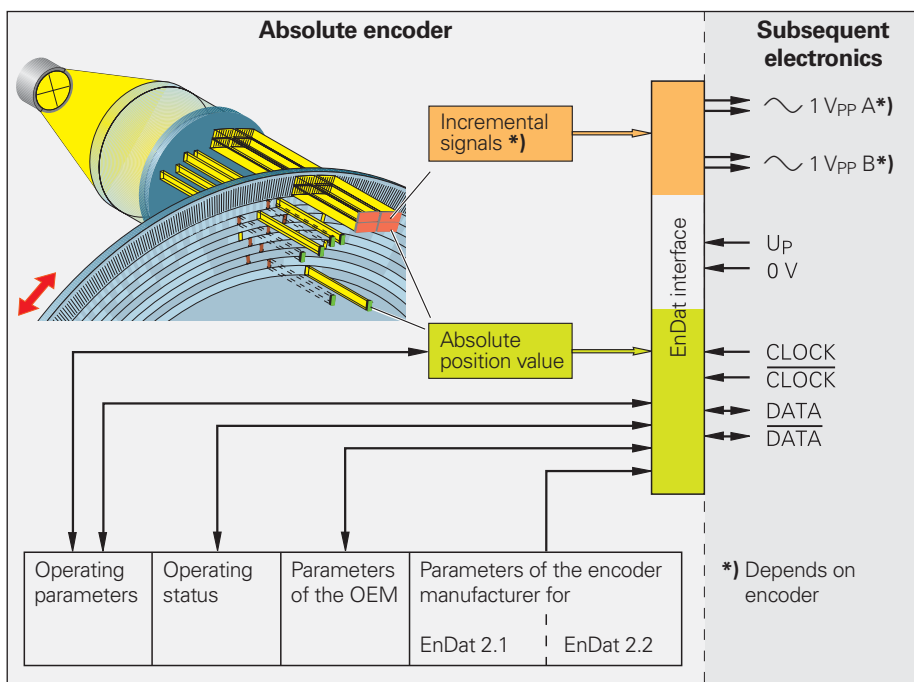

To ensure **reliability of data transfer**, a cyclic redundancy check (CRC) is performed through the logical processing of the individual bit values of a data word. This 5-bit long CRC concludes every transmission. The CRC is decoded in the receiver electronics and compared with the data word. This largely eliminates errors caused by disturbances during data transfer.

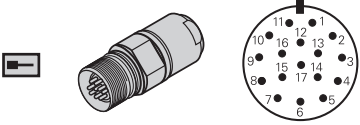

# Pin Layout

**17-pin coupling M23**



	Power supply					Incremental signals <sup>1)</sup>				Absolute position values			
	<b>7</b>	<b>1</b>	<b>10</b>	<b>4</b>	<b>11</b>	<b>15</b>	<b>16</b>	<b>12</b>	<b>13</b>	<b>14</b>	<b>17</b>	<b>8</b>	<b>9</b>
	<b>U<sub>P</sub></b>	<b>Sensor</b> U <sub>P</sub>	0V	<b>Sensor</b> 0V	<b>Inside shield</b>	<b>A+</b>	<b>A-</b>	<b>B+</b>	<b>B-</b>	<b>DATA</b>	<b>DATA</b>	<b>CLOCK</b>	<b>CLOCK</b>
	Brown/ Green	Blue	White/ Green	White	/	Green/ Black	Yellow/ Black	Blue/ Black	Red/ Black	Gray	Pink	Violet	Yellow

**Cable shield** connected to housing; **U<sub>P</sub>** = power supply voltage



**Sensor:** The sensor line is connected internally with the corresponding power line

Vacant pins or wires must not be used!

<sup>1)</sup> Only with ordering designations EnDat 01 and EnDat 02

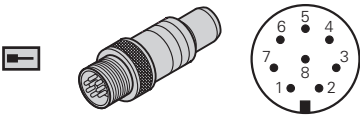
**8-pin coupling M12**







	Power supply				Absolute position values			
	<b>2</b>	<b>8</b>	<b>1</b>	<b>5</b>	<b>3</b>	<b>4</b>	<b>7</b>	<b>6</b>
	<b>U<sub>P</sub></b> <sup>1)</sup>	<b>U<sub>P</sub></b>	<b>0V</b> <sup>1)</sup>	<b>0V</b>	<b>DATA</b>	<b>DATA</b>	<b>CLOCK</b>	<b>CLOCK</b>
	Blue	Brown/Green	White	White/Green	Gray	Pink	Violet	Yellow

**Cable shield** connected to housing; **U<sub>P</sub>** = power supply voltage

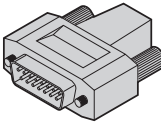
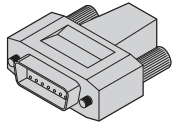
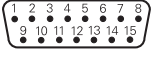
Vacant pins or wires must not be used!

<sup>1)</sup> For parallel supply lines

<b>15-pin D-sub connector, male</b> for IK 115/IK 215						<b>15-pin D-sub connector, female</b> for HEIDENHAIN controls and IK 220							
													
													
						Incremental signals <sup>1)</sup>				Absolute position values			
						<b>1</b>	<b>9</b>	<b>3</b>	<b>11</b>	<b>5</b>	<b>13</b>	<b>8</b>	<b>15</b>
						<b>3</b>	<b>4</b>	<b>6</b>	<b>7</b>	<b>5</b>	<b>8</b>	<b>14</b>	<b>15</b>
						<b>A+</b>	<b>A-</b>	<b>B+</b>	<b>B-</b>	<b>DATA</b>	<b>DATA</b>	<b>CLOCK</b>	<b>CLOCK</b>
						Green/ Black	Yellow/ Black	Blue/ Black	Red/ Black	Gray	Pink	Violet	Yellow

**Cable shield** connected to housing; **U<sub>P</sub>** = power supply voltage

**Sensor:** The sensor line is connected internally with the corresponding power line

Vacant pins or wires must not be used!

<sup>1)</sup> Only with ordering designations EnDat 01 and EnDat 02









# Interfaces

## Fanuc and Mitsubishi Pin Layouts

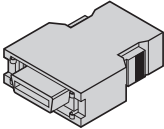
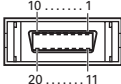
### Fanuc pin layout

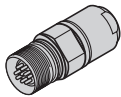
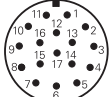
HEIDENHAIN encoders with the code letter F after the model designation are suited for connection to Fanuc controls with

- **Fanuc 01 serial interface**  
with 1 MHz communication rate
- **Fanuc 02 serial interface**  
with 1 MHz or 2 MHz communication rate

15-pin Fanuc connector					17-pin HEIDENHAIN coupling				
									
	Power supply					Absolute position values			
	9	18/20	12	14	16	1	2	5	6
	7	1	10	4	–	14	17	8	9
	<b>Up</b>	<b>Sensor Up</b>	<b>0V</b>	<b>Sensor 0V</b>	<b>Shield</b>	<b>Serial Data</b>	<b>Serial Data</b>	<b>Request</b>	<b>Request</b>
	Brown/ Green	Blue	White/Green	White	–	Gray	Pink	Violet	Yellow

**Shield** on housing; **Up** = power supply voltage







**Sensor:** The sensor line is connected internally with the corresponding power line

Vacant pins or wires must not be used!

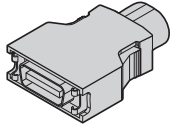
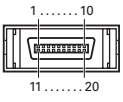
### Mitsubishi pin layout

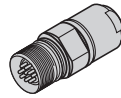
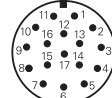
HEIDENHAIN encoders with the code letter M after the model designation are suited for connection to controls with the

**Mitsubishi high-speed serial interface.**

10 or 20-pin Mitsubishi connector					17-pin HEIDENHAIN coupling				
									
	Power supply					Absolute Position Values			
	10-pin	1	–	2	–	7	8	3	4
	20-pin	20	19	1	11	6	16	7	17
		7	1	10	4	14	17	8	9
		<b>Up</b>	<b>Sensor Up</b>	<b>0V</b>	<b>Sensor 0V</b>	<b>Serial Data</b>	<b>Serial Data</b>	<b>Request frame</b>	<b>Request frame</b>
		Brown/Green	Blue	White/Green	White	Gray	Pink	Violet	Yellow

**Shield** on housing; **Up** = power supply voltage



**Sensor:** The sensor line is connected internally with the corresponding power line

Vacant pins or wires must not be used!

# Connecting Elements and Cables

## General Information

**Connector (insulated):** Connecting element with coupling ring; available with male or female contacts.

Symbols  

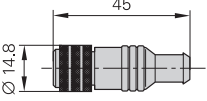

**M12**

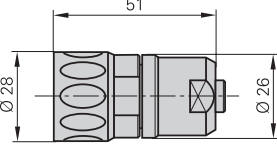

**M23**





**Flange socket:** Permanently mounted on the encoder or a housing, with external thread (like the coupling), and available with male or female contacts.

Symbols  

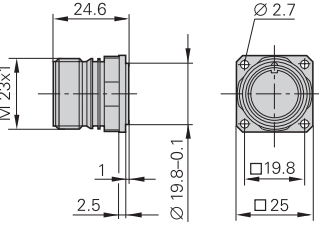
**M23**



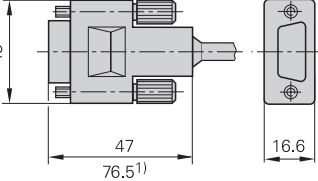

**D-sub connector:** For HEIDENHAIN controls, counters and IK absolute value cards.

Symbols  



<sup>1)</sup>With integrated interpolation electronics

**Coupling (insulated):** Connecting element with external thread. Available with male or female contacts.

Symbols  

**M12**

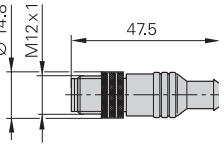

**M23**

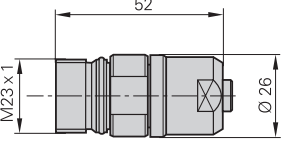

**Mounted coupling with central fastening**

Cutout for mounting

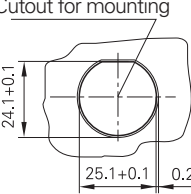

**M23**

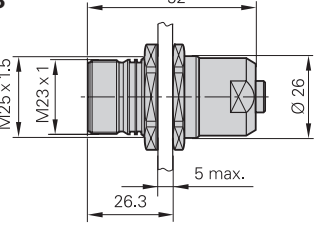

**Mounted coupling with flange**

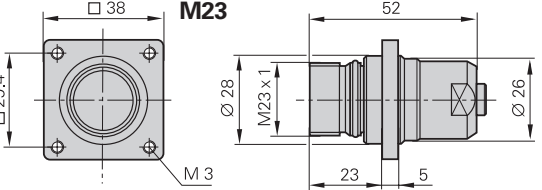

The pins on connectors are **numbered** in the direction opposite to those on couplings or flange sockets, regardless of whether the contacts are



When engaged, the connections provide **protection** to IP 67 (D-sub connector: IP 50; IEC 60529). When not engaged, there is no protection.

### Accessories for flange sockets and M23 mounted couplings

**Bell seal**  
ID 266526-01

**Threaded metal dust cap**  
ID 219926-01



# Adapter Cables

For incremental linear encoders		Cable Ø	LB 382/372 LF 183	LF 481	LS 187/177 LS 487/477
Adapter cable with 12-pin M23 coupling (male)		6 mm	310 128-xx	310 123-xx	360 645-xx
Adapter cable without connector		6 mm	310 131-xx	310 134-xx	354 319-xx
Adapter cable with 12-pin M23 connector (male)		6 mm 4.5 mm	310 127-xx –	310 122-xx –	344 228-xx 352 611-xx
Adapter cable in metal armor with 12-pin M23 connector (male)		10 mm	310 126-xx	310 121-xx	344 451-xx
Adapter cable with 15-pin D-sub connector		6 mm	298 429-xx	298 430-xx	360 974-xx

For absolute linear encoders – EnDat		Cable Ø	LC 183 LC 483 with incremental signals	LC 183 LC 483 without incremental signals
Adapter cable with 17-pin M23 coupling (male)		6 mm	533 631-xx	–
Adapter cable in metal armor with 17-pin M23 coupling (male)		10 mm	558 362-xx	–
Adapter cable with 15-pin D-sub connector		6 mm	558 714-xx	–
Adapter cable with 8-pin M12 coupling (male)		4.5 mm	–	533 661-xx
Adapter cable in metal armor with 8-pin M12 coupling (male)		10 mm	–	550 678-xx

For absolute linear encoders – Fanuc/Mitsubishi		Cable Ø	LC 193F LC 493F	LC 193M LC 493M
Adapter cable with 17-pin M23 coupling (male)		6 mm 4.5 mm	– 547 300-xx	
Adapter cable in metal armor with 17-pin M23 coupling (male)		10 mm	555 541-xx	
Adapter cable with 15-pin Fanuc connector with 20-pin Mitsubishi connector with 10-pin Mitsubishi connector		4.5 mm 6 mm 6 mm	545 547-xx – –	– 599 685-xx 640 915-xx
Adapter cable in metal armor with 15-pin Fanuc connector with 20-pin Mitsubishi connector with 10-pin Mitsubishi connector		10 mm 10 mm 10 mm	551 027-xx – –	– 599 688-xx 640 916-xx

Available cable lengths: 1 m/3 m/6 m/9 m





# Connecting Cables $\sim 1 V_{PP}$

TTL  
EnDat

12-pin M23    17-pin M23    8-pin M12

		for $\sim 1 V_{PP}$ TTL	for EnDat with incremental signals SSI	for EnDat without incremental signals
<b>PUR connecting cables</b>	<b>8-pin:</b> $[(4 \times 0.14 \text{ mm}^2) + (4 \times 0.34 \text{ mm}^2)]$ <b>12-pin:</b> $[4(2 \times 0.14 \text{ mm}^2) + (4 \times 0.5 \text{ mm}^2)]$ <b>17-pin:</b> $[(4 \times 0.14 \text{ mm}^2) + 4(2 \times 0.14 \text{ mm}^2) + (4 \times 0.5 \text{ mm}^2)]$		$\varnothing 6 \text{ mm}$	$\varnothing 8 \text{ mm}$
<b>Complete</b> with connector (female) and coupling (male)		298 401-xx	323 897-xx	368 330-xx
<b>Complete</b> with connector (female) and connector (male)		298 399-xx	–	–
<b>Complete</b> with connector (female) and D-sub connector (female) for IK 220		310 199-xx	332 115-xx	–
<b>Complete</b> with connector (female) and D-sub connector (male) for IK 115/IK 215		310 196-xx	324 544-xx	524 599-xx
<b>With one</b> connector (female)		309 777-xx	309 778-xx	559 346-xx
<b>Cable without connectors</b> , $\varnothing 8 \text{ mm}$		244 957-01	266 306-01	–
<b>Mating element on connecting cable to connector on encoder cable</b>	<b>Connector (female)</b> for cable $\varnothing 8 \text{ mm}$ 	291 697-05	291 697-26	–
<b>Connector on cable</b> for connection to subsequent electronics	<b>Connector (male)</b> for cable $\varnothing 4.5 \text{ mm}$ $\varnothing 8 \text{ mm}$ $\varnothing 6 \text{ mm}$ 	291 697-06 291 697-08 291 697-07	291 697-27	–
<b>Coupling on connecting cable</b>	<b>Coupling (male)</b> for cable $\varnothing 4.5 \text{ mm}$ $\varnothing 6 \text{ mm}$ $\varnothing 8 \text{ mm}$ 	291 698-14 291 698-03 291 698-04	291 698-25 291 698-26 291 698-27	–
<b>Flange socket</b> for mounting on the subsequent electronics	<b>Flange socket (female)</b> 	315 892-08	315 892-10	–
<b>Mounted couplings</b>	<b>With flange (female)</b> $\varnothing 6 \text{ mm}$ $\varnothing 8 \text{ mm}$ 	291 698-17 291 698-07	291 698-35	–
	<b>With flange (male)</b> $\varnothing 6 \text{ mm}$ $\varnothing 8 \text{ mm}$ 	291 698-08 291 698-31	291 698-41 291 698-29	–
	<b>With central fastening (male)</b> $\varnothing 6 \text{ mm}$ 	291 698-33	291 698-37	–
<b>Adapter connector</b> $\sim 1 V_{PP}/11 \mu A_{PP}$ For converting the $1 V_{PP}$ signals to $11 \mu A_{PP}$ ; M23 connector (female) 12-pin and M23 connector (male) 9-pin		364 914-01	–	–

# Connecting Cables Fanuc Mitsubishi

			for Fanuc	for Mitsubishi
<b>PUR connecting cables</b>				
<b>Complete</b> with 17-pin M23 connector (female) and Fanuc connector [[2 x 2 x 0.14 mm <sup>2</sup> ) + (4 x 1 mm <sup>2</sup> )]		Cable Ø 8 mm	534855-xx	–
<b>Complete</b> with 17-pin M23 connector (female) and 20-pin Mitsubishi connector [[2 x 2 x 0.14 mm <sup>2</sup> ) + (4 x 0.5 mm <sup>2</sup> )]		Cable Ø 6 mm	–	367958-xx
<b>Complete</b> with 17-pin M23 connector (female) and 10-pin Mitsubishi connector [[2 x 2 x 0.14 mm <sup>2</sup> ) + (4 x 1 mm <sup>2</sup> )]		Cable Ø 8 mm	–	573661-xx
<b>Cable without connectors</b> [[2 x 2 x 0.14 mm <sup>2</sup> ) + (4 x 1 mm <sup>2</sup> )]		Cable Ø 8 mm	354608-01	

# General Electrical Information

## Power supply

The encoders require a **stabilized dc voltage  $U_p$**  as power supply. The required power supply and the current consumption are given in the respective *Specifications*. The permissible ripple content of the dc voltage is:

- High frequency interference  
 $U_{PP} < 250 \text{ mV}$  with  $dU/dt > 5 \text{ V}/\mu\text{s}$
- Low frequency fundamental ripple  
 $U_{PP} < 100 \text{ mV}$

The values apply as measured at the encoder, i.e., without cable influences. The voltage can be monitored and adjusted with the encoder's **sensor lines**. If a controllable power supply is not available, the voltage drop can be halved by switching the sensor lines parallel to the corresponding power lines.

Calculation of the **line drop**:

$$\Delta U = 2 \cdot 10^{-3} \cdot \frac{L_C \cdot I}{56 \cdot A_P}$$

where

- $\Delta U$ : Line drop in V
- $L_C$ : Cable length in m
- $I$ : Current consumption in mA
- $A_P$ : Cross section of power lines in  $\text{mm}^2$

## Switch-on/off behavior of the encoders

The output signals are valid no sooner than after switch-on time  $t_{SOT} = 1.3 \text{ s}$  (2 s for PROFIBUS-DP) (see diagram). During time  $t_{SOT}$  they can have any levels up to 5.5 V (with HTL encoders up to  $U_{Pmax}$ ). If an interpolation electronics unit is inserted between the encoder and the power supply, the unit's switch-on/off characteristics must also be considered. If the power supply is switched off, or when the supply voltage falls below  $U_{min}$ , the output signals are also invalid. This data applies to the encoders listed in the catalog—customized interfaces are not considered.

Encoders with new features and increased performance range may take longer to switch on (longer time  $t_{SOT}$ ). If you are responsible for developing subsequent electronics, please contact HEIDENHAIN in good time.

## Isolation

The encoder housings are isolated against internal circuits.

Rated surge voltage: 500 V (preferred value as per VDE 0110 Part 1, overvoltage category II, contamination level 2)

## Cable

HEIDENHAIN cables are mandatory for **safety-related applications**.

The **cable lengths** listed in the *Specifications* apply only to HEIDENHAIN cables and the recommended input circuitry of the subsequent electronics.

## Durability

All encoders have polyurethane (PUR) cables. PUR cables are resistant to oil, hydrolysis and microbes in accordance with **VDE 0472**. They are free of PVC and silicone and comply with UL safety directives. The **UL certification** AWM STYLE 20963 80 °C 30 V E63216 is documented on the cable.

## Temperature range

HEIDENHAIN cables can be used for

- fixed cables  $-40 \text{ °C}$  to  $85 \text{ °C}$
- frequent flexing  $-10 \text{ °C}$  to  $85 \text{ °C}$

Cables with limited resistance to hydrolysis and microbes are rated for up to  $100 \text{ °C}$ .

If necessary, please ask for assistance from HEIDENHAIN Traunreut.

## Bend radius

The permissible bend radii  $R$  depend on the cable diameter and the configuration:

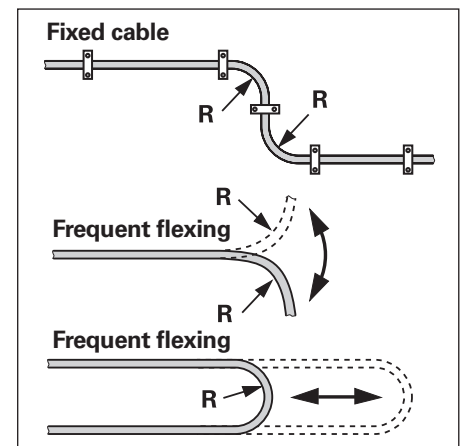
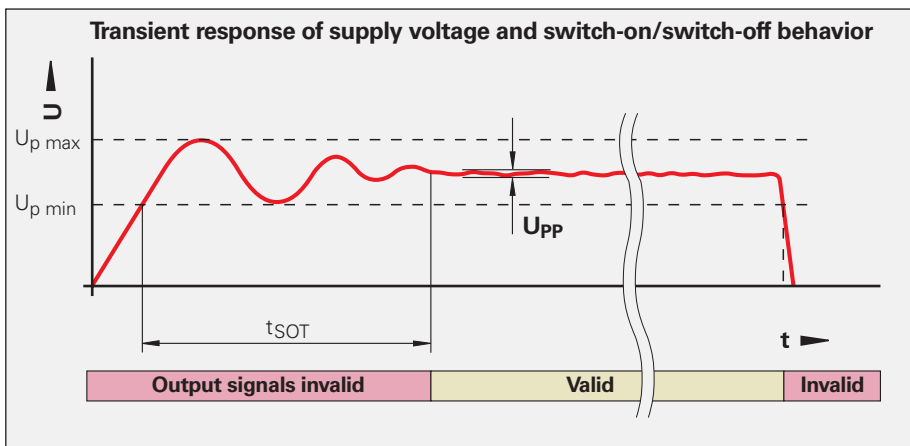

Connect HEIDENHAIN position encoders only to subsequent electronics whose power supply is generated through double or strengthened insulation against line voltage circuits. Also see **IEC 364-4-41: 1992**, modified Chapter 411 regarding "protection against both direct and indirect touch" (PELV or SELV). If position encoders or electronics are used in safety-related applications, they must be operated with protective extra-low voltage (PELV) and provided with overcurrent protection or, if required, with overvoltage protection.

Cable	Cross section of power supply lines $A_P$				Bend radius $R$	
	$1 \text{ V}_{PP}/\text{TTL}/\text{HTL}$	$11 \mu\text{A}_{PP}$	EnDat/SSI 17-pin	EnDat <sup>4)</sup> 8-pin	Fixed cable	Frequent flexing
$\varnothing 3.7 \text{ mm}$	$0.05 \text{ mm}^2$	–	–	–	$\geq 8 \text{ mm}$	$\geq 40 \text{ mm}$
$\varnothing 4.3 \text{ mm}$	$0.24 \text{ mm}^2$	–	–	–	$\geq 10 \text{ mm}$	$\geq 50 \text{ mm}$
$\varnothing 4.5 \text{ mm}$ $\varnothing 5.1 \text{ mm}$	$0.14/0.05^2) \text{ mm}^2$	$0.05 \text{ mm}^2$	$0.05 \text{ mm}^2$	$0.14 \text{ mm}^2$	$\geq 10 \text{ mm}$	$\geq 50 \text{ mm}$
$\varnothing 6 \text{ mm}$ $\varnothing 10 \text{ mm}^1)$	$0.19/0.14^3) \text{ mm}^2$	–	$0.08 \text{ mm}^2$	$0.34 \text{ mm}^2$	$\geq 20 \text{ mm}$ $\geq 35 \text{ mm}$	$\geq 75 \text{ mm}$ $\geq 75 \text{ mm}$
$\varnothing 8 \text{ mm}$ $\varnothing 14 \text{ mm}^1)$	$0.5 \text{ mm}^2$	$1 \text{ mm}^2$	$0.5 \text{ mm}^2$	$1 \text{ mm}^2$	$\geq 40 \text{ mm}$ $\geq 100 \text{ mm}$	$\geq 100 \text{ mm}$ $\geq 100 \text{ mm}$

<sup>1)</sup>Metal armor    <sup>2)</sup>Length gauges    <sup>3)</sup>LIDA 400    <sup>4)</sup>Also Fanuc, Mitsubishi

## Electrically Permissible Speed/ Traversing Speed

The maximum permissible shaft speed or traversing speed of an encoder is derived from

- the **mechanically** permissible shaft speed / traversing velocity (if listed in *Specifications*) and
- the **electrically** permissible shaft speed/traversing velocity.  
For encoders with **sinusoidal output signals**, the electrically permissible shaft speed/traversing velocity is limited by the  $-3\text{dB}/-6\text{dB}$  cutoff frequency or the permissible input frequency of the subsequent electronics. For encoders with **square-wave signals**, the electrically permissible shaft speed/traversing velocity is limited by
  - the maximum permissible scanning/output frequency  $f_{\text{max}}$  of the encoder and
  - the minimum permissible edge separation  $a$  of the subsequent electronics.

### For angular or rotary encoders

$$n_{\text{max}} = \frac{f_{\text{max}}}{z} \cdot 60 \cdot 10^3$$

### For linear encoders

$$v_{\text{max}} = f_{\text{max}} \cdot \text{SP} \cdot 60 \cdot 10^{-3}$$

where

- $n_{\text{max}}$ : Electrically permissible speed in  $\text{min}^{-1}$
- $v_{\text{max}}$ : Electrically permissible traversing speed in  $\text{m/min}$
- $f_{\text{max}}$ : Max. scanning/output frequency of encoder or input frequency of subsequent electronics in  $\text{kHz}$
- $z$ : Line count of the angle or rotary encoder per  $360^\circ$
- SP: Signal period of the linear encoder in  $\mu\text{m}$

## Noise-Free Signal Transmission

### Electromagnetic compatibility/ CE compliance

When properly installed, and when HEIDENHAIN connecting cables and cable assemblies are used, HEIDENHAIN encoders fulfill the requirements for electromagnetic compatibility according to 2004/108/EC with respect to the generic standards for:

#### • Noise immunity EN 61000-6-2:

- Specifically:
- ESD EN 61 000-4-2
  - Electromagnetic fields EN 61 000-4-3
  - Burst EN 61 000-4-4
  - Surge EN 61 000-4-5
  - Conducted disturbances EN 61 000-4-6
  - Power frequency magnetic fields EN 61 000-4-8
  - Pulse magnetic fields EN 61 000-4-9

#### • Interference EN 61000-6-4:

- Specifically:
- For industrial, scientific and medical (ISM) equipment EN 55 011
  - for information technology equipment EN 55 022

### Transmission of measuring signals— electrical noise immunity

Noise voltages arise mainly through capacitive or inductive transfer. Electrical noise can be introduced into the system over signal lines and input or output terminals.

Possible sources of noise are:

- Strong magnetic fields from transformers, brakes and electric motors
- Relays, contactors and solenoid valves
- High-frequency equipment, pulse devices, and stray magnetic fields from switch-mode power supplies
- AC power lines and supply lines to the above devices

### Protection against electrical noise

The following measures must be taken to ensure disturbance-free operation:

- Use only HEIDENHAIN cables.
- Use connectors or terminal boxes with metal housings. Do not conduct any extraneous signals.
- Connect the housings of the encoder, connector, terminal box and evaluation electronics through the shield of the cable. Connect the shielding in the area of the cable outlets to be as induction-free as possible (short, full-surface contact).
- Connect the entire shielding system with the protective ground.
- Prevent contact of loose connector housings with other metal surfaces.
- The cable shielding has the function of an equipotential bonding conductor. If compensating currents are to be expected within the entire system, a separate equipotential bonding conductor must be provided. Also see **EN 50 178/4.98** Chapter 5.2.9.5 regarding "protective connection lines with small cross section."
- Do not lay signal cables in the direct vicinity of interference sources (inductive consumers such as contacts, motors, frequency inverters, solenoids, etc.).
- Sufficient decoupling from interference-signal-conducting cables can usually be achieved by an air clearance of 100 mm or, when cables are in metal ducts, by a grounded partition.
- A minimum spacing of 200 mm to inductors in switch-mode power supplies is required. See also **EN 50 178/4.98** Chapter 5.3.1.1, regarding cables and lines, as well as **EN 50 174-2/09.01**, Chapter 6.7, regarding grounding and potential compensation.
- When using **rotary encoders in electromagnetic fields** greater than 30 mT, HEIDENHAIN recommends consulting with the main facility in Traunreut.

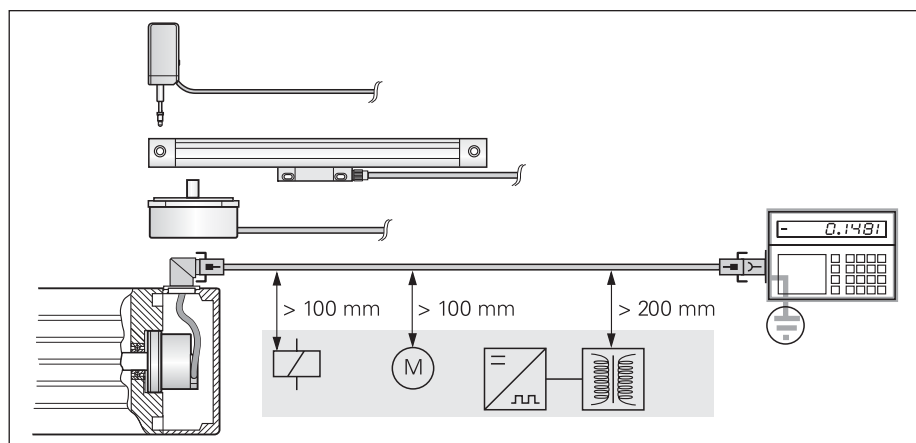

Minimum distance from sources of interference

Both the cable shielding and the metal housings of encoders and subsequent electronics have a shielding function. The housings must have the **same potential** and be connected to the main signal ground over the machine chassis or by means of a separate potential compensating line. Potential compensating lines should have a minimum cross section of  $6 \text{ mm}^2$  (Cu).

# Evaluation Electronics

## IBV series

### Interpolation and digitizing electronics

Interpolation and digitizing electronics interpolate and digitize the sinusoidal output signals ( $\sim 1 V_{PP}$ ) from HEIDENHAIN encoders up to 100-fold, and convert them to TTL square-wave pulse sequences.



IBV 101

For more information, see the *IBV 100*, *IBV 600* and *APE 371* Product Information documents.

	IBV 101	IBV 102	IBV 660	APE 371
<b>Input signals</b>	$\sim 1 V_{PP}$			
Encoder inputs	Flange socket, 12-pin female			15-pin D-sub connector
<b>Interpolation</b> (adjustable)	5-fold 10-fold	25-fold 50-fold 100-fold	25-fold 50-fold 100-fold 200-fold 400-fold	5-fold 10-fold 20-fold 25-fold 50-fold 100-fold
<b>Output signals</b>	<ul style="list-style-type: none"> <li>Two TTL square-wave pulse trains <math>U_{a1}</math> and <math>U_{a2}</math> and their inverted signals <math>\overline{U_{a1}}</math> and <math>\overline{U_{a2}}</math></li> <li>Reference pulse <math>U_{a0}</math> and <math>\overline{U_{a0}}</math></li> <li>Fault detection signal <math>\overline{U_{aS}}</math></li> <li>Limit and homing signals H, L (for APE 371)</li> </ul>			
<b>Power supply</b>	$5 V \pm 5\%$			

## IK 220

### Universal PC counter card

The IK 220 is an expansion board for PCs for recording the measured values of two incremental or absolute linear or angle encoders. The subdivision and counting electronics subdivide the sinusoidal input signals up to 4096-fold. A driver software package is included in delivery.



For more information, see the *IK 220* Product Information sheet.

	IK 220			
<b>Input signals</b> (switchable)	$\sim 1 V_{PP}$	$\sim 11 \mu A_{PP}$	EnDat 2.1	SSI
Encoder inputs	2 D-sub connections (15-pin) male			
Input frequency	$\leq 500$ kHz	$\leq 33$ kHz	–	
Cable length	$\leq 60$ m		$\leq 10$ m	
<b>Signal subdivision</b> (signal period : meas. step)	Up to 4 096-fold			
<b>Data register for measured values</b> (per channel)	48 bits (44 bits used)			
<b>Internal memory</b>	For 8 192 position values			
<b>Interface</b>	PCI bus (plug and play)			
<b>Driver software and demonstration program</b>	<b>For Windows 98/NT/2000/XP</b> in VISUAL C++, VISUAL BASIC and BORLAND DELPHI			
<b>Dimensions</b>	Approx. 190 mm $\times$ 100 mm			

# HEIDENHAIN Measuring Equipment

The **PWM 9** is a universal measuring device for checking and adjusting HEIDENHAIN incremental encoders. There are different expansion modules available for checking the different encoder signals. The values can be read on an LCD monitor. Soft keys provide ease of operation.



	PWM 9
<b>Inputs</b>	Expansion modules (interface boards) for 11 $\mu$ APP; 1 V <sub>PP</sub> ; TTL; HTL; EnDat 2.1*/SSI*/commutation signals *No display of position values or parameters
<b>Functions</b>	<ul style="list-style-type: none"> <li>• <b>Measures</b> signal amplitudes, current consumption, operating voltage, scanning frequency</li> <li>• <b>Graphically displays</b> incremental signals (amplitudes, phase angle and on-off ratio) and the reference-mark signal (width and position)</li> <li>• <b>Displays symbols</b> for the reference mark, fault detection signal, counting direction</li> <li>• <b>Universal counter</b>, interpolation selectable from single to 1 024-fold</li> <li>• <b>Adjustment support</b> for exposed linear encoders</li> </ul>
<b>Outputs</b>	<ul style="list-style-type: none"> <li>• Inputs are connected through to the subsequent electronics</li> <li>• BNC sockets for connection to an oscilloscope</li> </ul>
<b>Power supply</b>	10 to 30 V, max. 15 W
<b>Dimensions</b>	150 mm x 205 mm x 96 mm

The **IK 215** is an adapter card for PCs for inspecting and testing absolute HEIDENHAIN encoders with EnDat or SSI interface. Parameters can be read and written via the EnDat interface.



	IK 215
<b>Encoder input</b>	EnDat (absolute value or incremental signals) or SSI
<b>Interface</b>	PCI bus, Rev. 2.1
<b>Application software</b>	<b>Operating system:</b> Windows 2000/XP <b>Features:</b> Display of position value Counter for incremental signals EnDat functionality Installation wizard for Exl 1100/1300
<b>Signal subdivision for incremental signals</b>	Up to 65 536-fold
<b>Dimensions</b>	100 mm x 190 mm



# HEIDENHAIN

## DR. JOHANNES HEIDENHAIN GmbH

Dr.-Johannes-Heidenhain-Straße 5  
83301 Traunreut, Germany

☎ +49 (8669) 31-0

FAX +49 (8669) 5061

E-Mail: info@heidenhain.de

www.heidenhain.de

### DE HEIDENHAIN Technisches Büro Nord

12681 Berlin, Deutschland  
☎ (030) 54705-240  
E-Mail: tbn@heidenhain.de

### HEIDENHAIN Technisches Büro Mitte

08468 Heinsdorfergrund, Deutschland  
☎ (03765) 69544  
E-Mail: tbn@heidenhain.de

### HEIDENHAIN Technisches Büro West

44379 Dortmund, Deutschland  
☎ (0231) 618083-0  
E-Mail: tbw@heidenhain.de

### HEIDENHAIN Technisches Büro Südwest

70771 Leinfelden-Echterdingen, Deutschland  
☎ (0711) 993395-0  
E-Mail: tbsw@heidenhain.de

### HEIDENHAIN Technisches Büro Südost

83301 Traunreut, Deutschland  
☎ (08669) 31-1345  
E-Mail: tbs@heidenhain.de

### AR NAKASE SRL.

B1653AOX Villa Ballester, Argentina  
☎ +54 (11) 47684242  
E-Mail: nakase@nakase.com

### AT HEIDENHAIN Techn. Büro Österreich

83301 Traunreut, Germany  
☎ +49 (8669) 31-1337  
E-Mail: tba@heidenhain.de

### AU FCR Motion Technology Pty. Ltd

Laverton North 3026, Australia  
☎ +61 (3) 93626800  
E-Mail: vicsales@fcrmotion.com

### BE HEIDENHAIN NV/SA

1760 Roosdaal, Belgium  
☎ +32 (54) 343158  
E-Mail: sales@heidenhain.be

### BG ESD Bulgaria Ltd.

Sofia 1172, Bulgaria  
☎ +359 (2) 9632949  
E-Mail: info@esd.bg

### BR DIADUR Indústria e Comércio Ltda.

04763-070 – São Paulo – SP, Brazil  
☎ +55 (11) 5696-6777  
E-Mail: diadur@diadur.com.br

### BY Belarus → RU

### CA HEIDENHAIN CORPORATION

Mississauga, Ontario L5T 2N2, Canada  
☎ +1 (905) 670-8900  
E-Mail: info@heidenhain.com

### CH HEIDENHAIN (SCHWEIZ) AG

8603 Schwerzenbach, Switzerland  
☎ +41 (44) 8062727  
E-Mail: verkauf@heidenhain.ch

### CN DR. JOHANNES HEIDENHAIN (CHINA) Co., Ltd.

Beijing 101312, China  
☎ +86 10-80420000  
E-Mail: sales@heidenhain.com.cn

### CS Serbia and Montenegro → BG

### CZ HEIDENHAIN s.r.o.

106 00 Praha 10, Czech Republic  
☎ +420 272658131  
E-Mail: heidenhain@heidenhain.cz

### DK TP TEKNIK A/S

2670 Greve, Denmark  
☎ +45 (70) 100966  
E-Mail: tp-gruppen@tp-gruppen.dk

### ES FARRESA ELECTRONICA S.A.

08028 Barcelona, Spain  
☎ +34 934092491  
E-Mail: farresa@farresa.es

### FI HEIDENHAIN Scandinavia AB

02770 Espoo, Finland  
☎ +358 (9) 8676476  
E-Mail: info@heidenhain.fi

### FR HEIDENHAIN FRANCE sarl

92310 Sèvres, France  
☎ +33 0141143000  
E-Mail: info@heidenhain.fr

### GB HEIDENHAIN (G.B.) Limited

Burgess Hill RH15 9RD, United Kingdom  
☎ +44 (1444) 247711  
E-Mail: sales@heidenhain.co.uk

### GR MB Milionis Vassilis

17341 Athens, Greece  
☎ +30 (210) 9336607  
E-Mail: bmilioni@otenet.gr

### HK HEIDENHAIN LTD

Kowloon, Hong Kong  
☎ +852 27591920  
E-Mail: service@heidenhain.com.hk

### HR Croatia → SL

### HU HEIDENHAIN Kereskedelmi Képviselet

1239 Budapest, Hungary  
☎ +36 (1) 4210952  
E-Mail: info@heidenhain.hu

### ID PT Servitama Era Toolsindo

Jakarta 13930, Indonesia  
☎ +62 (21) 46834111  
E-Mail: ptset@group.gts.co.id

### IL NEUMO VARGUS MARKETING LTD.

Tel Aviv 61570, Israel  
☎ +972 (3) 5373275  
E-Mail: neumo@neumo-vargus.co.il

### IN ASHOK & LAL

Chennai – 600 030, India  
☎ +91 (44) 26151289  
E-Mail: ashoklal@satyam.net.in

### IT HEIDENHAIN ITALIANA S.r.l.

20128 Milano, Italy  
☎ +39 02270751  
E-Mail: info@heidenhain.it

### JP HEIDENHAIN K.K.

Tokyo 102-0073, Japan  
☎ +81 (3) 3234-7781  
E-Mail: sales@heidenhain.co.jp

### KR HEIDENHAIN LTD.

Suwon, South Korea, 443-810  
☎ +82 (31) 2011511  
E-Mail: info@heidenhain.co.kr

### MK Macedonia → BG

### MX HEIDENHAIN CORPORATION MEXICO

20235 Aguascalientes, Ags., Mexico  
☎ +52 (449) 9130870  
E-Mail: info@heidenhain.com

### MY ISOSERVE Sdn. Bhd

56100 Kuala Lumpur, Malaysia  
☎ +60 (3) 91320685  
E-Mail: isoserve@po.jaring.my

### NL HEIDENHAIN NEDERLAND B.V.

6716 BM Ede, Netherlands  
☎ +31 (318) 581800  
E-Mail: verkoop@heidenhain.nl

### NO HEIDENHAIN Scandinavia AB

7300 Orkanger, Norway  
☎ +47 72480048  
E-Mail: info@heidenhain.no

### PH Machinebanks Corporation

Quezon City, Philippines 1113  
☎ +63 (2) 7113751  
E-Mail: info@machinebanks.com

### PL APS

02-489 Warszawa, Poland  
☎ +48 228639737  
E-Mail: aps@apserwis.com.pl

### PT FARRESA ELECTRÓNICA, LDA.

4470 - 177 Maia, Portugal  
☎ +351 229478140  
E-Mail: fep@farresa.pt

### RO Romania → HU

### RU OOO HEIDENHAIN

125315 Moscow, Russia  
☎ +7 (495) 931-9646  
E-Mail: info@heidenhain.ru

### SE HEIDENHAIN Scandinavia AB

12739 Skärholmen, Sweden  
☎ +46 (8) 53193350  
E-Mail: sales@heidenhain.se

### SG HEIDENHAIN PACIFIC PTE LTD.

Singapore 408593,  
☎ +65 6749-3238  
E-Mail: info@heidenhain.com.sg

### SK Slovakia → CZ

### SL Posredništvo HEIDENHAIN SAŠO HÜBL s.p.

2000 Maribor, Slovenia  
☎ +386 (2) 4297216  
E-Mail: hubl@siol.net

### TH HEIDENHAIN (THAILAND) LTD

Bangkok 10250, Thailand  
☎ +66 (2) 398-4147-8  
E-Mail: info@heidenhain.co.th

### TR T&M Mühendislik San. ve Tic. LTD. ŞTİ.

34738 Erenköy-Istanbul, Turkey  
☎ +90 (216) 3022345  
E-Mail: info@tmmuhendislik.com.tr

### TW HEIDENHAIN Co., Ltd.

Taichung 407, Taiwan  
☎ +886 (4) 23588977  
E-Mail: info@heidenhain.com.tw

### UA Ukraine → RU

### US HEIDENHAIN CORPORATION

Schaumburg, IL 60173-5337, USA  
☎ +1 (847) 490-1191  
E-Mail: info@heidenhain.com

### VE Maquinaria Diekmann S.A.

Caracas, 1040-A, Venezuela  
☎ +58 (212) 6325410  
E-Mail: purchase@diekmann.com.ve

### VN AMS Advanced Manufacturing Solutions Pte Ltd

HCM City, Việt Nam  
☎ +84 (8) 9123658 - 8352490  
E-Mail: davidgoh@amsvn.com

### ZA MAFEMA SALES SERVICES C.C.

Midrand 1685, South Africa  
☎ +27 (11) 3144416  
E-Mail: mailbox@mafema.co.za

