

OMP60 - optical machine probe

The probe transmits through 360° for ease of operation on a vertical or horizontal CNC machining centre.

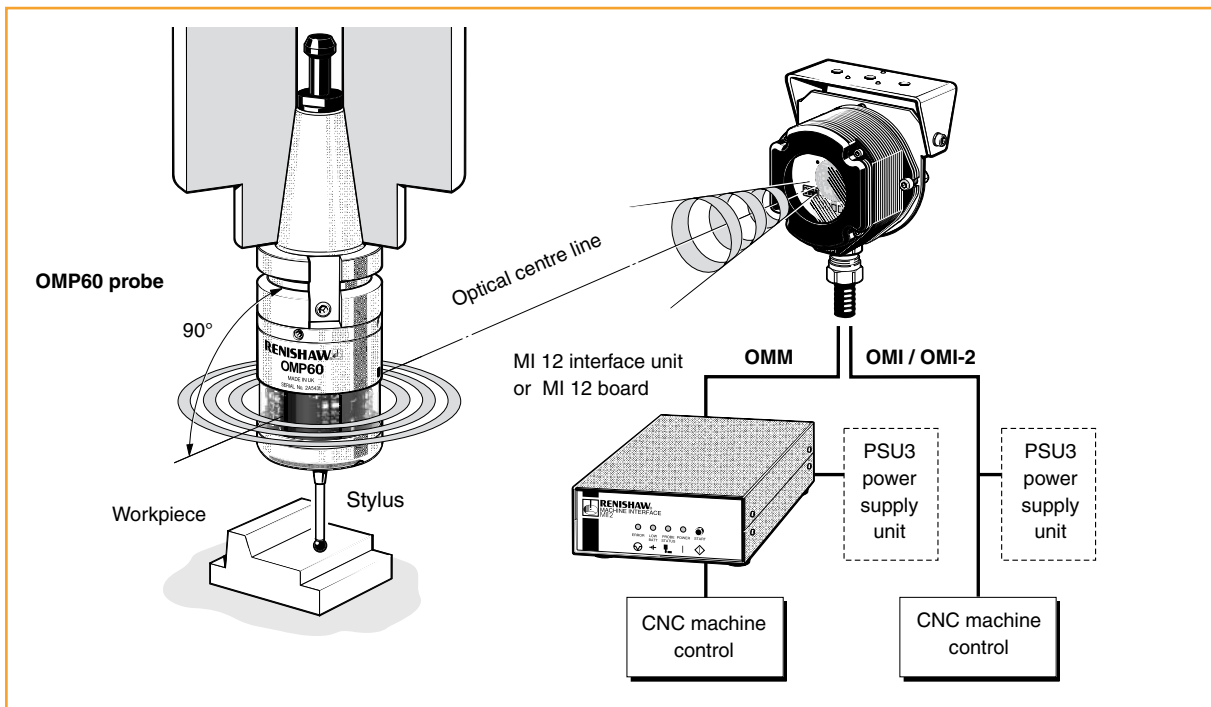

Features

• Signal transmission

The OMP60 transmits through 360°, at an angle of 90° to the spindle axis, with a range of up to 6 m (19.7 ft).

• Battery life

Typical battery life with standard alkaline AA batteries is in excess of 170 hours continuous use, or in excess of 110 days at 5 % usage.

When lithium thionyl chloride (LTC) batteries are selected, battery life of 600 hours or 340 days respectively can be achieved.

• Probe repeatability

Repeatability, 1.0 µm (0.00004 in) is certified at 480 mm/min (1.57 ft/min) with 50 mm stylus.

• Probe switch-on

Probe switch-on is user configurable between M code, auto start, spin or shank.

• Probe switch-off

Probe switch-off is user configurable between M code, time, spin or shank.

• Probe sealing

Sealed to IPX8 and designed for the machine tool environment.

• Software for probe routines

The OMP60 is suitable for use with Renishaw single and double touch probing cycles.

• Visible probe diagnostic LEDs

Provides on/off, seated/triggered and low battery information.

• Optical receivers

Compatible with OMI and OMM (Legacy transmission) and OMI-2 (Modulated transmission).

• Weak link supplied with each kit

For use with steel styli to protect the probe in event of excessive stylus overtravel.

Performance envelope - OMP60

The OMP60 has a 360° transmission envelope over the ranges shown below.

The probe system should be positioned so that the optimum range can be achieved over the full travel of the machine axis.

The OMP and OMM, OMI or OMI-2 may deviate from the optical centre line, provided opposing light cones always overlap, with transmitters and receivers in the others field

of view (eye to eye).

Natural reflective surfaces within the machine may affect the signal transmission range.

Coolant residue, accumulating on the OMP and OMM, OMI or OMI-2 windows, will have a detrimental effect on transmission performance. Wipe clean as often as is necessary to maintain unrestricted transmission.

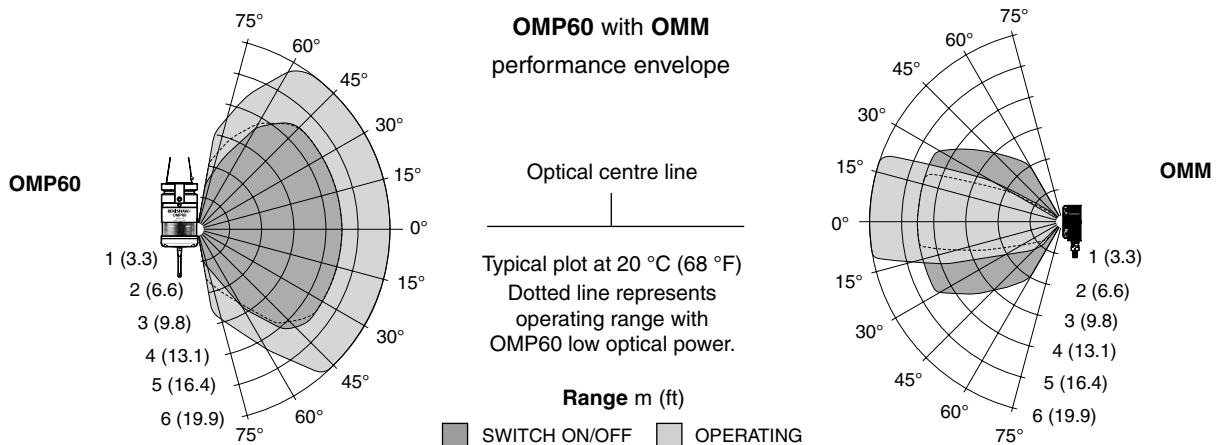
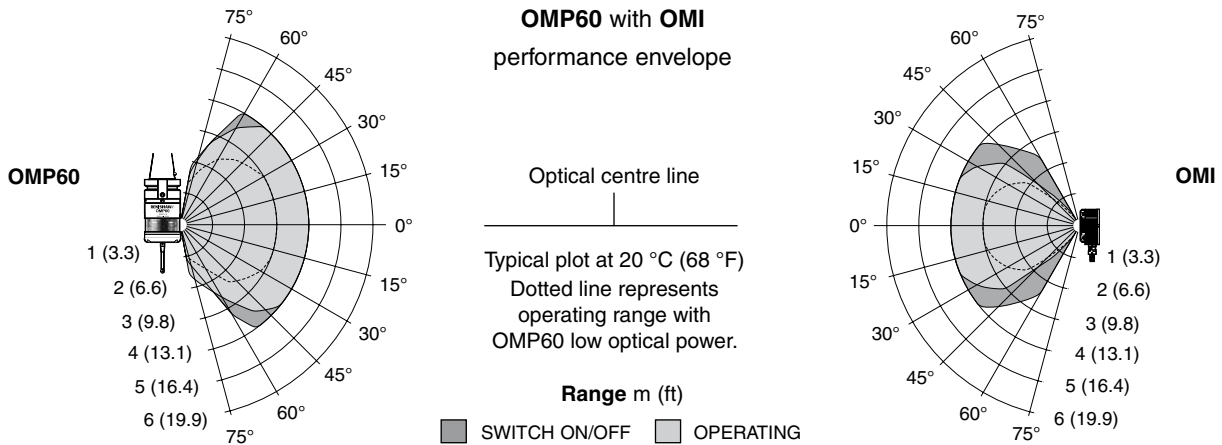
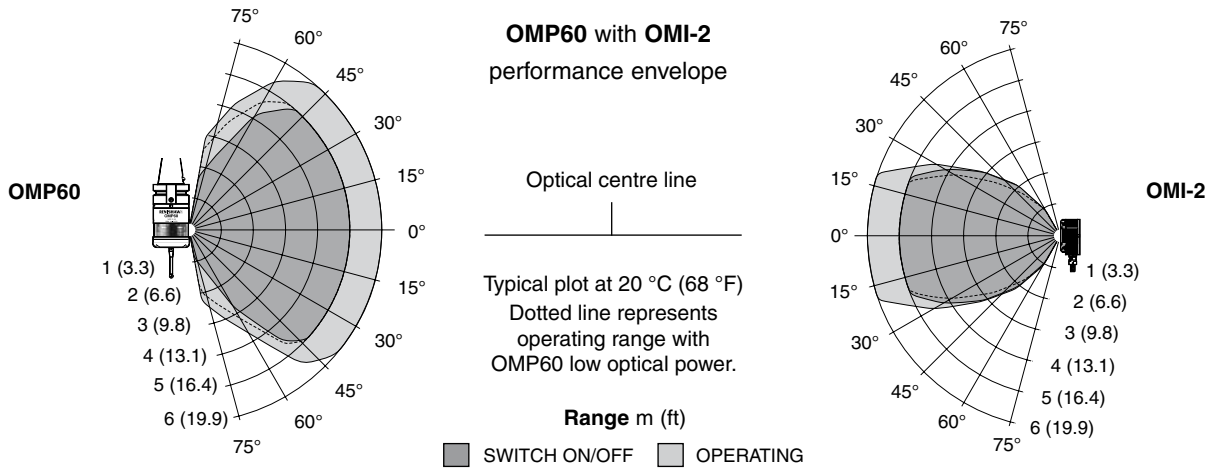



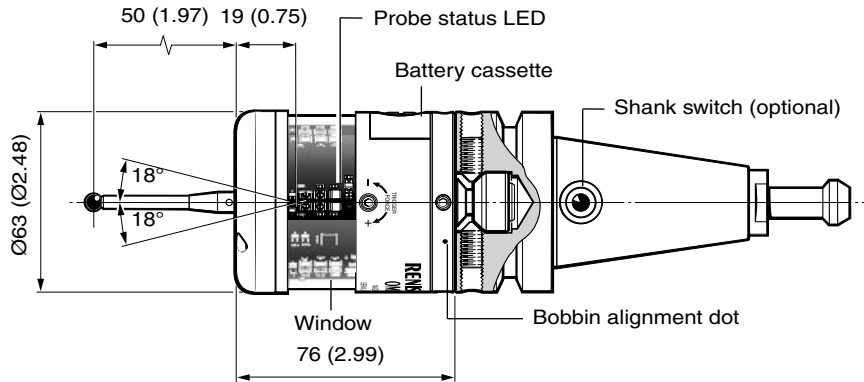

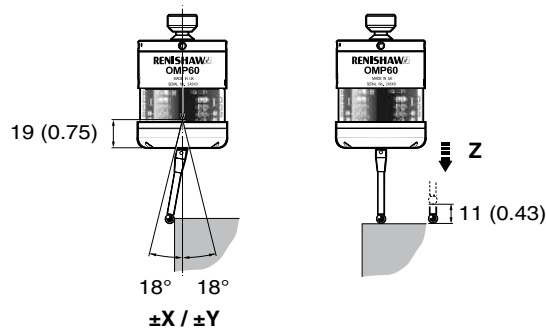

OMP60 dimensions mm (in)



STYLUS OVERTRAVEL LIMITS		
Stylus length	$\pm X / \pm Y$	Z
50 (1.96)	21 (0.82)	11 (0.43)
100 (3.93)	37 (1.45)	11 (0.43)



Probe status LEDs

LED colour	Probe status	Graphic hint
Flashing green	Probe seated in operating mode	
Flashing red	Probe triggered in operating mode	
Flashing green and blue	Probe seated in operating mode - low battery	
Flashing red and blue	Probe triggered in operating mode - low battery	
Constant or flashing red	Battery dead	
Flashing red or flashing red and green or sequence (when batteries are inserted)	Unsuitable battery	

OMP60 specification

Primary application	Inspection probe for machining centres
Sense directions	5 way $\pm X$ $\pm Y$ +Z
Weight with batteries without batteries	878 g (30.79 oz) 834 g (29.42 oz)
Trigger force using 50 mm (1.97 in) stylus low force direction	X / Y 0.75 N (75 gf) Z 5.30 N (530 gf)
Trigger force using 50 mm (1.97 in) stylus high force direction	X / Y 1.40 N (140 gf) Z 5.30 N (530 gf)
Maximum acceleration using 50 mm stylus	150 m/s ²
Overtrel	X / Y 18° Z 11 mm (0.43 in)
Sealing	IPX8 (BS 5490, IEC 529) I atmosphere
Repeatability maximum 2 σ value in any direction	1.0 μ m 0.00004 in

Probe settings

The OMP60 probe can be in one of three modes:

- 1. Stand-by mode** - The OMP60 is waiting for a switch-on signal to be received.
- 2. Operating mode** - Activated by one of the switch-on methods described below. In this mode the OMP60 is now ready for use.
- 3. Configuration mode** - The trigger logic configuration method allows the following settings to be configured.

Enhanced trigger software

Probes subjected to high levels of vibration or shock loads may output signals without having contacted any surface. The enhanced trigger software improves the probes resistance to these effects.

Low optical power

Where the separation between OMP60 and the OMI-2, OMI or OMM is small, the low optical power setting may be used.

In this setting, the optical transmission range will be reduced as shown on performance envelopes, so battery life will be extended.

Dotted lines on performance envelopes represent the OMP60 in low optical power.

Optical transmission start mode

Probes subjected to particular forms of light interference may accept spurious start signals.

The OMP60 can be operated in either either 'Legacy' or 'Modulated, optical transmission modes.

In Legacy mode a start filter improves the probe's resistance to these effects.

In Modulated mode, the OMP60 becomes compatible for use with the OMI-2, to provide substantially increased resistance to light interference.

Probe switch on / switch off methods

Switch on / switch off options are configurable

1. Optical on / Optical off
2. Optical on / Timer off
3. Spin on / Spin off
4. Spin on / Timer off
5. Shank switch on / Shank switch off

Switch on method	Switch off methods available
<p>Optical on Optical switch on when commanded by M code.</p>	<p>Optical off Optical switch off when commanded by M code. A timer automatically switches the probe off after 90 min. from last trigger if not turned off by M code.</p> <p>Timer off (time out) Time out will occur (12, 33 or 134 sec) after the last probe trigger or reset.</p>
<p>Optical on Optical switch on when commanded by auto start</p>	<p>Timer off (time out) Time out will occur (12, 33 or 134 sec) after the last probe trigger or reset.</p>
<p>Spin on Spin at 650 rev/min for 1 sec minimum (6 sec maximum).</p>	<p>Spin off Spin at 650 rev/min for 1 sec minimum (6 sec maximum). A timer automatically switches the probe off after 90 min. from last trigger if not spun.</p> <p>Timer off (time out) Time out will occur (12, 33 or 134 sec) after the last probe trigger or reset.</p>
<p>Shank switch on</p>	<p>Shank switch off</p>

Battery life

Typical battery reserve life

Using typical alkaline batteries at 5% usage, the probe will continue to operate for approximately one week, after a low battery warning is first indicated. Replace the batteries as soon as possible.

After batteries are inserted into the OMP60, flashing LEDs will indicate the current settings.

Low power mode should be used whenever possible for increased battery life.

Maximum battery life is achieved when Lithium Thionyl Chloride (LTC) batteries are used in conjunction with low power mode.

LEGACY optical transmission mode *					
Two AA type batteries	Stand-by life (days - max)	5% usage = 72 minutes/day (days - max)		Continuous use (hours - max)	
		Standard power mode	Low power mode	Standard power mode	Low power mode
Alkaline	468	71	111	100	172
LTC	1019	229	339	350	595

MODULATED optical transmission mode *					
Two AA type batteries	Stand-by life (days - max)	5% usage = 72 minutes/day (days - max)		Continuous use (hours - max)	
		Standard power mode	Low power mode	Standard power mode	Low power mode
Alkaline	468	65	86	90	125
LTC	1019	203	270	300	433

★ Data applicable for both 'optical switch on' and 'Shank / spin switch on' transmission start modes

OMP60M modular system

OMP60M is a special modular version of OMP60. It enables probe inspection of part features inaccessible to OMP60, by fitting selected adaptors and extensions as shown.

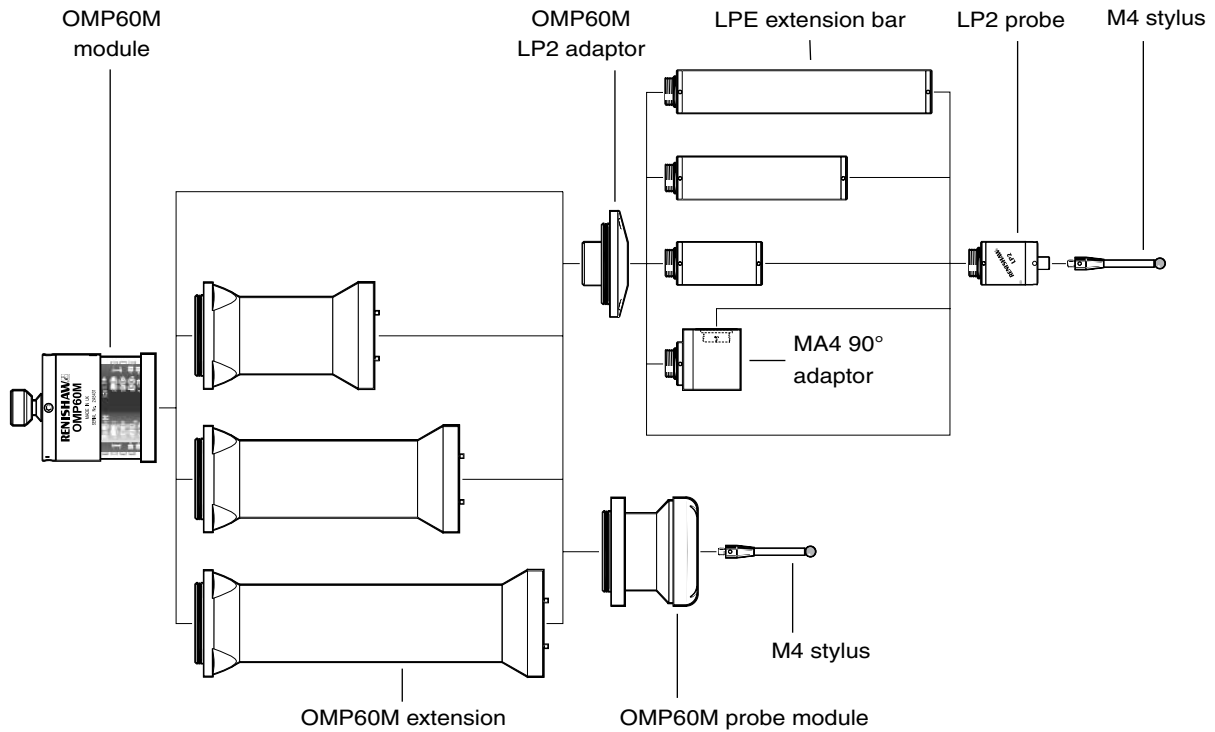

OMP60M dimensions

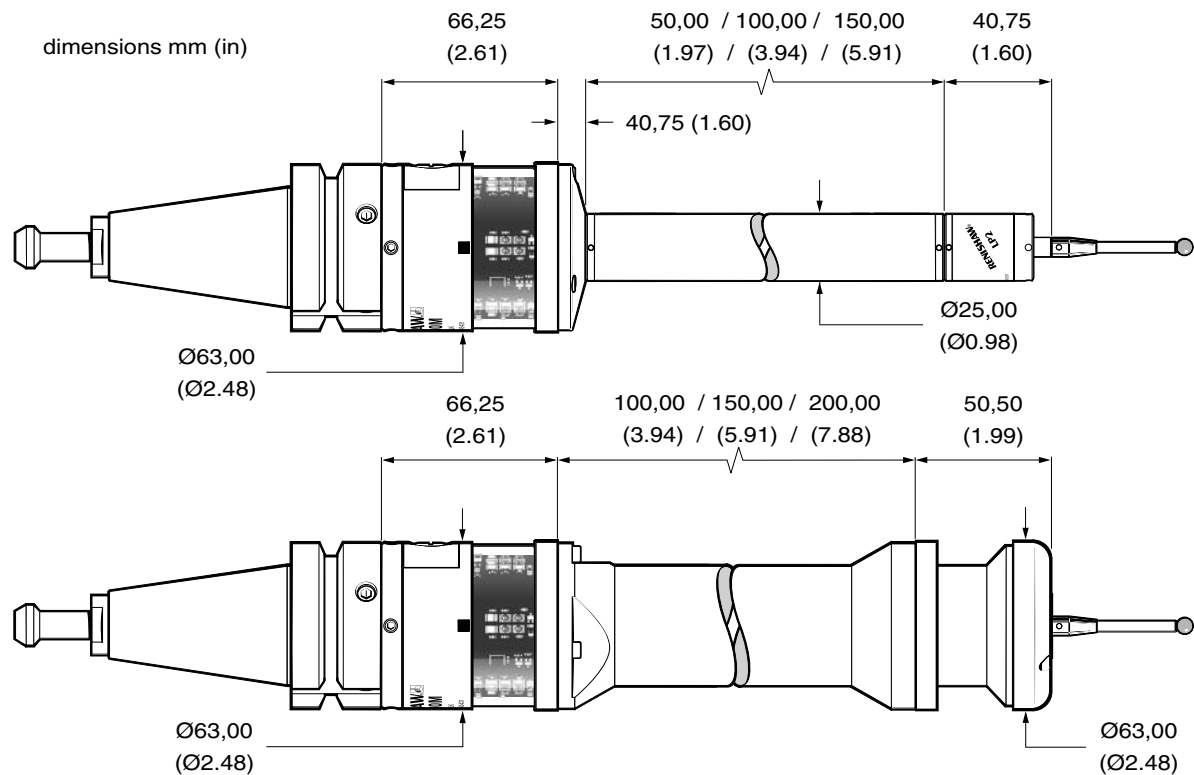

Parts list - Please quote the Part no. when ordering equipment.

Type	Part no.	Description
OMP60	A-4038-0001	OMP60 probe with batteries, tool kit and User's guide (set to optical on/optical off) - legacy transmission.
OMP60	A-4038-0002	OMP60 probe with batteries, tool kit and User's guide (set to optical on/time off 134 sec) - legacy transmission.
OMP60	A-4038-2001	OMP60 probe with batteries, tool kit and User's guide (set to optical on/optical off) - modulated transmission.
OMP60	A-4038-2002	OMP60 probe with batteries, tool kit and User's guide (set to optical on/time off 134 sec) - modulated transmission
OMP60M module	A-4038-1003	OMP60M module with batteries, tool kit and User's guide. (set to optical on/optical off) - legacy transmission.
OMP60M module	A-4038-0368	OMP60M module with batteries, tool kit and User's guide. (set to optical on/time off 134 sec) - legacy transmission.
OMP60M module	A-4038-0369	OMP60M module with batteries, tool kit and User's guide. (set to optical on/optical off) - modulated transmission.
OMP60M module	A-4038-0370	OMP60M module with batteries, tool kit and User's guide. (set to optical on/time off 134 sec) - modulated transmission.
Battery	P-BT03-0005	AA battery - Alkaline - supplied as standard with probe (two required).
Battery	P-BT03-0008	AA battery - Lithium thionyl chloride (two required).
Stylus	A-5000-3709	PS3-1C ceramic stylus 50 mm long with Ø6 mm ball.
Weak link kit	A-2085-0068	Weak link (Part no. M-2085-0069 x 2) and 5 mm AF spanner.
Tool kit	A-4038-0304	Probe tool kit comprising: Ø1.98 mm stylus tool, 2.0 mm AF hexagon key, 2.5 mm AF hexagon key (x 2), 4 mm AF hexagon key, and shank grub screws (x 2).
Diaphragm kit	A-4038-0302	OMP60 outer diaphragm.
Battery cassette kit	A-4038-0300	OMP60 battery cassette assembly.
Cassette seal kit	A-4038-0301	Battery cassette seal.
Bobbin kit	A-4038-0303	Bobbin for shank switch (supplied with shank switch).

Parts list - Please quote the Part no. when ordering equipment.

Type	Part no.	Description
Extension L100	A-4038-1010	OMP60M extension - 100 mm long.
Extension L150	A-4038-1027	OMP60M extension - 150 mm long.
Extension L200	A-4038-1028	OMP60M extension - 200 mm long.
Probe module	A-4038-1002	OMP60M probe module assembly.
OMP60M LP2 adaptor	A-4038-0212	OMP60M LP2 adaptor assembly
LPE1	A-2063-7001	LPE1 extension bar - 50 mm long.
LPE2	A-2063-7002	LPE2 extension bar - 100 mm long.
LPE3	A-2063-7003	LPE3 extension bar - 150 mm long.
MA4	A-2063-7600	MA4 90° adaptor assembly.
Publications		
OMP60	—	See User's guide H-2000-5221 OMP60.
Styli	—	See Brochure H-1000-3200 Styli and accessories.
Software	—	See Data sheet H-2000-2289 Probe software for machine tools
Shanks	—	See Data sheet H-2000-2011 Shanks.
OMM	—	See Data sheet H-2000-2275 Optical module machine.
OMI	—	See Data sheet H-2000-2285 Optical machine interface.
OMI-2	—	See Data sheet H-2000-2205 Optical machine interface - 2.
MI 12	—	See Data sheet H-2000-2195 MI 12 interface unit.
PSU3	—	See Data sheet H-2000-2200 PSU3 power supply unit.

